



Precision
Planting®

PRECISION TECHNOLOGY INSTITUTE

2022 RESEARCH SUMMARY
PONTIAC, IL

2022 PTI Farm Research Summary

Table of Contents:

Introduction and Guide to Summary Report	5
Top 10/Bottom 10 Return on Investment Performers	6
Corn Summary of 2022 FurrowJet® Applications	113
Corn Summary of 2022 Conceal® Applications	129
Soybeans Table of Contents	163
Soybeans Summary of 2022 FurrowJet® & Conceal® Application	234
Wrap Up	256-259
Acknowledgments and Legal Statement	260

Corn Planting Principles:

Planting Date	7
Starter Fertilizer Response by Date	8-9
vSet® Planter Singulation	10
Manual Planting Depth	11
SmartDepth® Planting Depth	12-14
Keeton® Seed Firmer	15
STP Opening Disc	16-17
Reveal® Residue Management	18-19
CleanSweep® Residue Management	20-21
2022 Crop Year Day of Emergence	22-24
Multi-Year Day of Emergence	25
High Speed Planting	26
SeedTube Planting	27
Closing Wheel System	28-32
Downforce Management	33-35
Planter "All-Wrong"	36
Multi-Genetic Planting	37-38
Rosen's Stride Bio™ Hopper Box	39
Rootella® F Inoculant	40
TerraMax MicroAZ-ST Dry™ Inoculant	41
Terrasym® 450 + Dust™ Hopper Box	42
15" Row Corn Seeding Rate	132-133
20" Row Corn Seeding Rate	134-135
30" Row Corn Seeding Rate	136-137
30" vs 20" Row Corn	138
30" vs 15" Row Corn	139
Multi-Year 20" vs 30" Row Corn	140
20" Solar Corridor	141
Corn Strip Planting	142-149

Corn Dry Fertilizer Studies:

Broadcast vs Banding	43-44
Broadcast vs Banding Rate Efficiency	45-47
Mosaic® Sulfur/Boron Dry Fertilizer	48-49
Calcium Products SO ₄ ²⁻	50
Planter Applied Micro-Nutrient	51-53

Corn Nitrogen Programs:

Pivot Bio PROVEN40® Nitrogen Mgt.	86-87
Envita® Nitrogen Mgt.	88-89
Source™ Foliar V4 Application	90
Source™ Foliar VT Application	91
QLF BOOST™ Nitrogen Inclusion	92-93
Nitrogen Sealer	120

Corn FurrowJet® Programs:

Marco QuickGrow™ LTE FurrowJet®	83
Nachurs® impulse® FurrowJet®	84
Nachurs® Start2Finish	85
Aqua-Yield® NanoCS®	94-95
Aqua-Yield® CXPro	96-97
AGROTECH NutriCharge®	98
10-34-0 FurrowJet®	99
Phosphorus Placement	100-101
QLF™ L-CBF 7-21-3 MKP FurrowJet®	102
Stoller®USA FurrowJet®	103-104
Ethos™ XB In-Furrow	105
Xyway® LFR® FurrowJet®	106-108
Kelpak® Bio-Stimulant	109-110
TerraMax FurrowJet®	111
FurrowJet® Side-Wall	112

Corn Cover Crop Studies:

Conceal® Nitrogen Mgt in Cover Crop	123-124
Continuous Corn Cover Crop	130
Corn after Soybean Cover Crop	131

Corn Conceal® Programs:

At-Plant Conceal® vs. Weed-N-Feed	114
Single vs. Dual Band Conceal® Nitrogen	115
At-Plant Nitrogen Placement	116-119
Conceal® K-Fuse® Potassium	121
Holganix® Bio 800+	122
Aqua-Yield® Nano N+®	125-126

PhycoTerra® ----- 127-128

Corn Foliar Programs:

Veltyma® Foliar Fungicide ----- 150
 TopGuard® EQ Foliar Fungicide ----- 151
 Miravis® Neo Foliar Fungicide ----- 152
 Ground vs. UAV Foliar Application ----- 153-154
 QLF L-CBF Amino 15™ Foliar ----- 155
 Aqua-Yield® NanoK® ----- 156-157
 Aqua-Yield® NanoPro® ----- 158

Corn Harvest Studies:

Chopping Corn Head ----- 159

Corn Tillage Studies:

Corn Tillage ----- 160-161
 Strip-Till Freshener ----- 162

Corn Intensive Management Studies:

High Management NETAFIM® Irrigation ----- 54
 NETAFIM® Sub-Surface vs Surface ----- 55-56
 Tile Drainage & Sub-Irrigation ----- 57-59
 High Management Strip Cropping ----- 60-62
 High Management The Andersons® ----- 63-64
 High Management AgroLiquid® ----- 65-66
 High Management Marco ----- 67-68
 High Management Stoller® USA ----- 69-70
 High Management Nachurs® ----- 71-72
 High Management Brandt® ----- 73-74
 High Management NMS LLC ----- 75-76
 High Management Marco/QLF® ----- 77-79
 High Management Ocean Blue Ag ----- 80-82

Soybean Planting Principles:

Planting Date ----- 164
 Multi-Year Early Plant Date ----- 165
 Soybean Early Plant Maturity ----- 166
 Starter Fertilizer Response by Date ----- 167-168
 Manual Planting Depth ----- 169
 SmartDepth® Planting Depth ----- 170-172
 Reveal® Residue Management ----- 173-174
 CleanSweep® Residue Management ----- 175-176
 Downforce Management ----- 177-179
 Keeton® Seed Firmer ----- 180
 Singulation ----- 181
 SeedRight Bundle Drop Singulation ----- 182
 STP Opening Discs ----- 183-184
 High Speed ----- 185
 Tillage/Closing Wheels ----- 186-189
 Rosens Stride Bio™ Hopper Box ----- 190

Rootella® F Inoculant ----- 192
 Cover Crop Study ----- 193-195
 Rolling ----- 235-237
 Strip Cropping ----- 238-243
 Strip Cropping System Summary ----- 244
 Chopping Corn Head ----- 252
 Row Width and Seeding Rate ----- 253-255

Soybean Dry Fertilizer Studies:

Broadcast vs Banding ----- 196-197
 Broadcast vs Banding Rate Efficiency ----- 198-200
 Calcium Products 98G® ----- 201
 Calcium Products SO4® ----- 202

Soybean FurrowJet® Programs:

TerraMax Liquid IF™ ----- 191
 Stoller®USA FurrowJet® ----- 220-221
 Marco Quick Grow LTE FurrowJet® ----- 222
 L-CBF 7-21-3 MKP FurrowJet® ----- 223
 FurrowJet® Side-Wall ----- 224

Soybean Foliar Programs:

QLF™ L-CBF 5-5-5-1S Study ----- 225
 Revytek™ Foliar Fungicide ----- 245
 Miravis® Neo™ Foliar Fungicide ----- 246
 AgroLiquid® Kapitalize® Foliar Nutrition ----- 247
 QLF L-CBF Amino 15™ Foliar ----- 248

Soybean Conceal® Programs:

Marco Fertilizer Conceal® 14-12-4-6S ----- 232
 Nachurs® Conceal® K-Fuse® Potassium ----- 233

Soybean Tillage Studies:

Soybean Tillage ----- 249-250
 Pre-Strip Vertical Tillage ----- 251

Soybean Intensive Mgt. Studies:

NETAFIM™ Irrigation Study ----- 203
 Soybean Seed Size ----- 204
 High Management Nachurs® ----- 205-206
 High Management AgroLiquid® ----- 207-208
 High Management the Andersons® ----- 209-210
 High Management Marco ----- 211-212
 High Management Stoller® USA ----- 213-214
 High Management Brandt® ----- 215-216
 High Management Ocean Blue Ag ----- 217-219
 Nachurs® At-Plant Nutrition Program ----- 226-227
 The Andersons® At-Plant Nutrition ----- 228-229
 AgroLiquid® At Plant Nutrition ----- 230-231

Become a PTI Insider Today!



InsidePTI is a new online video series where Jason Webster and the Precision Planting Team will give an inside look into all the studies being conducted at the PTI Farm in video form. Sign up today to receive these agronomic videos mailed directly to your email inbox. To sign up, simply go to [InsidePTI.com](https://www.insidepti.com) and soon you will get a behind the scenes look at the PTI Farm!

Become an Insider

A simple way to stay informed, as well as up to date on the research we are collecting here at the PTI Farm is to become an Insider. Subscribe to the InsidePTI weekly videos at [insidepti.com](https://www.insidepti.com) for all of your agronomic needs.

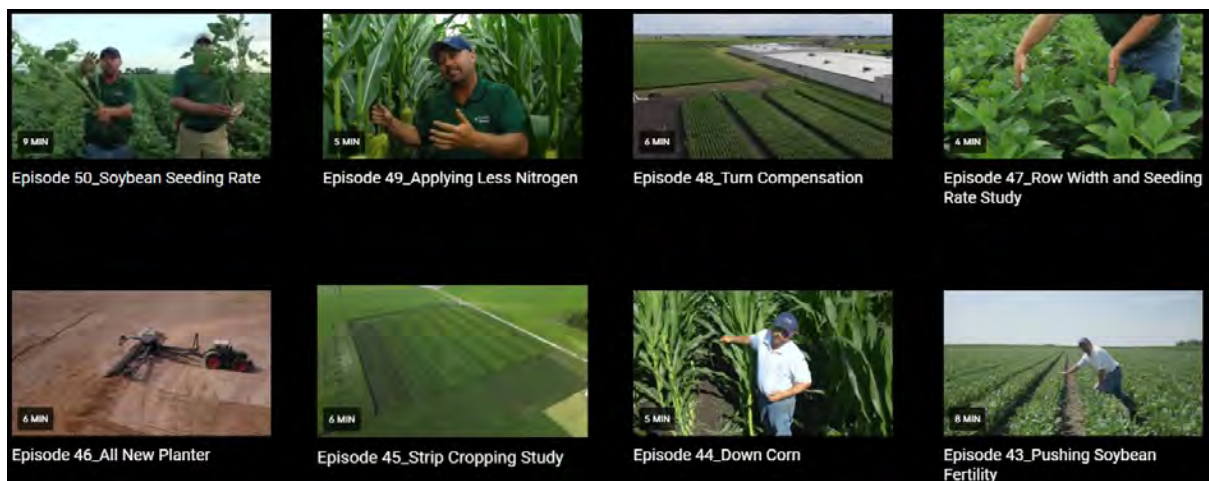

Introduction and Guide to Summary Report

Precision Planting is excited to share our 5th year of PTI research farm results and findings. We hope they provide useful insights that help drive thoughtful consideration around future crop management decisions. This publication is intended to summarize and explain the many agronomic trials that were implemented in 2022. This year we added 30 new agronomy trials to our testing program and are excited to release our findings in this report.

During the summer of 2022, the PTI Farm hosted thousands of growers from throughout the United States as well as six international countries including Germany, Canada, Argentina, Brazil, Hungary and the Ukraine. Farmers visited the PTI research farm to dive into agronomy field trials, see and understand real world agronomic problems, and were even able to experience some of the latest and greatest state-of-the-art technology in our ride and drive “SandBox” area. Field days started in July and lasted until the 2nd week of September, running Monday thru Friday of each week.

For the 2022 PTI Yield Summary Data, net returns are calculated with corn prices of \$6.00/Bu. and soybeans at \$13.96/Bu. These prices represent average **cash** prices for new crop 2022 corn and soybeans from the period of October 1st 2021, thru October 1st, 2022. At the bottom of each trial summary page, a brief explanation is listed to show Planting Date, Hybrid or Variety, Population, Row Width, Crop Rotation, and Commodity Price/Bu. and Pricing information that pertains to the products being evaluated.

Most starter fertilizer trials at the PTI Farm have a \$30 Re-allocation credit applied to each product in testing. This approach allows us to use the total intended fertility needed for soil test build-up and yield maintenance but allows the planned use of both dry fertilizer in the fall and liquid product on the planter without over-spending or over-applying more nutrients than needed. To accomplish this, we reduce our dry fertilizer rates by \$30/A. to account for the reallocation. All control tests in each study get the additional \$30/A. of fertilizer to achieve a typical 100% program without starter fertilizer on the planter.

Fall Dry Fertilizer: \$30 Reduction + At-Plant Liquid Starter



2022 Top and Bottom Return on Investment Performers

PTI Agronomic Study:	\$ ROI/A.	Page #
Top 10:		
1. High Management Soybeans	\$292.25	203-216
2. High Management Corn	\$252.74	54-82
3. NETAFIM® Drip Irrigation	\$168.80	54-56
4. Strip Cropping System	\$150.48	142-149
5. 15' & 30' Drainage Tile*	\$ 99.20	57-59
6. At-Plant Micronutrient: The Andersons® MicroMark® DG:10#	\$ 93.40	51-53
7. Multi-Genetic Corn Planting	\$ 85.80	37-38
8. SB FurrowForce® vs Dual Rubber Closing Wheels in No-Till	\$ 64.22	186-189
9. SB Marco NutriStart BOOST 14-12-4-6S: 15 Gal Conceal®	\$ 63.05	232
10. At-Plant Dual Band Conceal® vs Weed-n-Feed Nitrogen Prog.	\$ 61.20	114
Bottom 10:		
1. Optimum Corn Planting Date – May 20th	\$-170.07	7
2. Optimum Soybean Planting Date – April 26 th	\$-123.90	164
3. Planter All Wrong – Row Cleaners, DownForce, Singulation	\$-118.80	36
4. 20" Solar Corridor over 20" Corn: Population Average	\$ -92.70	141
5. 20" Corn Seeding Rate: Low Pop 32K vs EOSR* 40K	\$ -70.20	134-135
6. Corn High Speed Planting without High Speed Technology	\$ -66.60	27
7. Incorrect Corn Planting Depth	\$ -64.54	11-14
8. Growth Stage VT -20% Inclusion: Nitrogen Fixing/NUE* Study	\$ -63.62	90-91
9. 15" Corn Seeding Rate: Low Pop 32K vs EOSR* 40K	\$ -63.45	132-133
10. Overseeding Soybean Seeding Rate Study	\$ -61.68	253-255

*Gross return/Economic Optimum Seeding Rate/Nitrogen Use Efficiency

Corn Planting Date Study

Objective: To evaluate various corn planting dates throughout the spring to determine the optimum planting date. Once optimum planting date is discovered, economics can then be analyzed to determine yield loss and cost per acre when planting dates were not implemented within the optimum planting window.

Results: Later corn planted on May 20th achieved this year's optimum plant date at 278.7 Bu/A. (Table 1). Early planting dates of April 26th and May 2nd suffered yield losses of **-37.4** to **-34.1 Bu/A.**, while May 11th offered losses of **-15.9 Bu/A.** The latest plant date of June 6th was **-26.3 Bu/A.** off the pace from optimum plant date.

Table 2. illustrates the economics of the various corn planting dates and tells that story that early planting dates did not pay. April and 1st Week May plantings offered economic losses of **-\$204.62** to **-\$224.51/A.** May 11th plant dates resulted in losses of **-\$95.60/A.**, while the latest plant date of June 6th tallied losses of **-\$158.01/A.**

Table 3. summarizes the average yield from week-to-week plantings over a five-year time-period from 2018-2022. Over this timeframe, the planting dates that have suffered the highest yield losses have been ultra-early planting dates (1st and 2nd week April) with losses of **-26 to -28 Bu/A.** average yields and the late 4th week of May with **-26.7 Bu/A.**

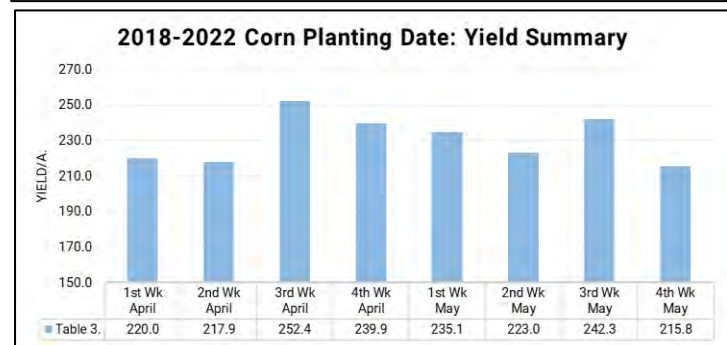
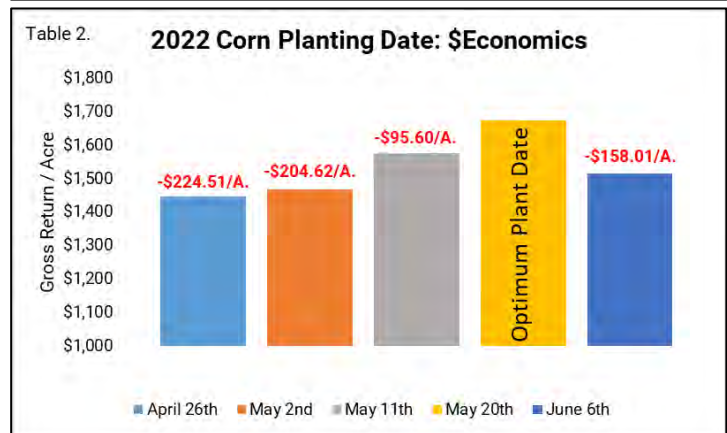
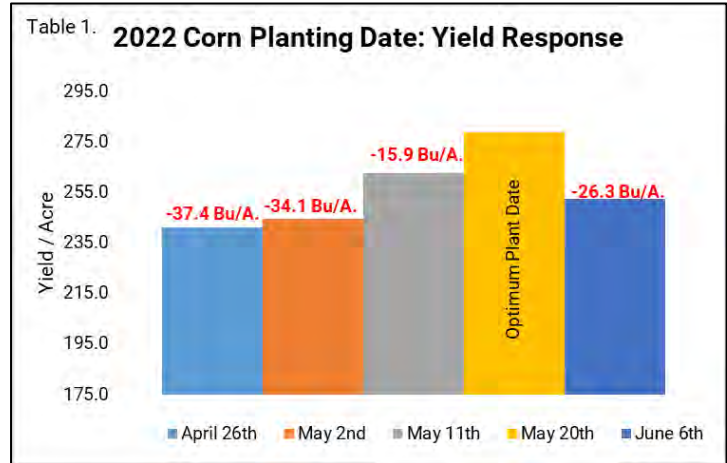

Corn Starter Fertilizer Response by Planting Date Study

Objective: To monitor the performance of starter fertilizer at various planting dates. When does starter fertilizer give the highest returns? Does starter fertilizer respond differently at earlier planted dates versus later? In this study we evaluate five planting dates consisting of April 26th, May 2nd, May 11th, May 20th and June 6th with and without a starter fertilizer, monitoring its performance throughout the planting season.

The starter fertilizer program used for this study consists of the following:



<u>Product</u>	<u>Fertilizer Analysis</u>	<u>Placement of Fertilizer</u>
3 Gal/A. Nachurs® Triple Option®	4-13-17-1S	FurrowJet® Center
3 Gal/A. Nachurs® Triple Option®	4-13-17-1S	FurrowJet® Wings
5 Gal/A. Nachurs® Throwback®	9-27-4-4S	Conceal® Single Band
20 Gal/A.UAN	32-0-0	Conceal® Single Band
3 Gal/A. Nachurs® K-Fuse®	6-0-12-12S	Conceal® Single Band

Figure 1. FurrowJet® Placement

Figure 2. Conceal® Placement



Corn Starter Fertilizer Response by Planting Date Study Continued

Results: Table 1. illustrates that every planting date achieved yield gains from starter fertilizer. All April and May planting dates resulted in yield gains of +10.9 to +12.1 Bu/A., while the last planting date of June 6th trended lower at +7.6 Bu/A. gains.

Economics indicate positive return on investment for all April and May plantings, however only ranged from +\$1 to +\$8.20/A. These disappointing revenue gains are the result of fertilizer costs increasing nearly 40% over 2021 prices.

June 6th planting dates (the last planting date) resulted in a negative return on investment of **-\$18.80/A.**

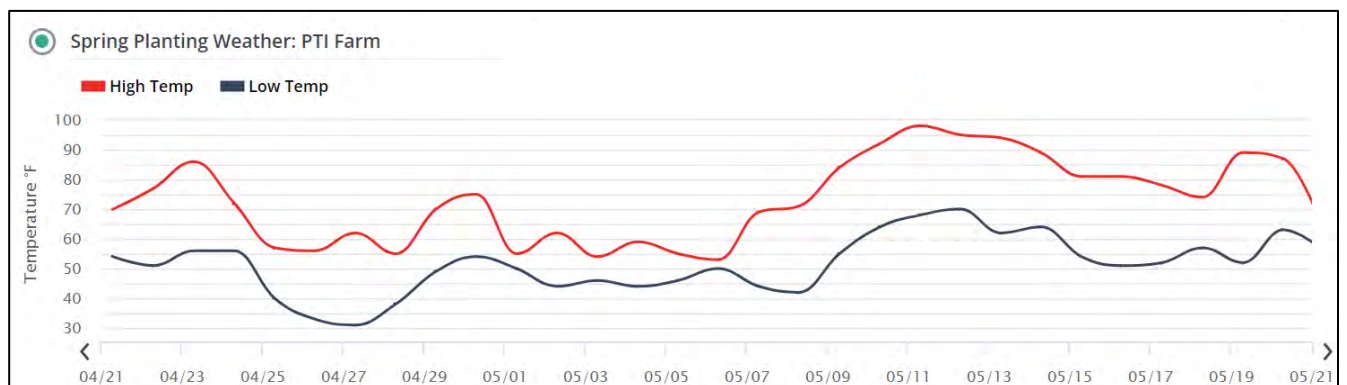
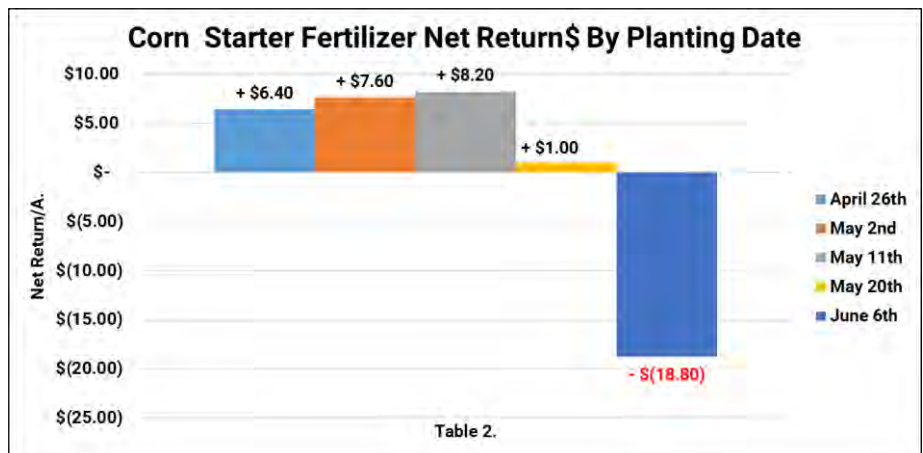
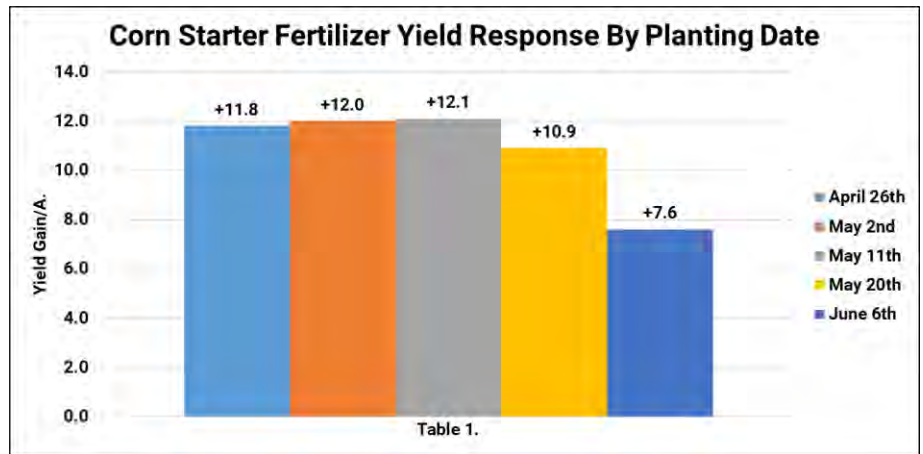

Planting Date: Varied Hybrid: GH11V78 Population: 36K Row Width: 30" Rotation: CAB Corn Price: \$6.00 Triple Option®: \$7.80/Gal
 Nacqurs Throwback: \$7.56/Gal K-Fuse®: \$6.60/Gal \$40 Fertilizer Reallocation

vSet® Planter Singulation Study

Objective: To evaluate how improper seed singulation affects corn yield. Modified vSet® seed plates with plugged and extra holes were used to create skips and doubles. These “goof” plates created an average of 95% spacing accuracy vs. the control at 99.5%.

Extra Holes = Doubles

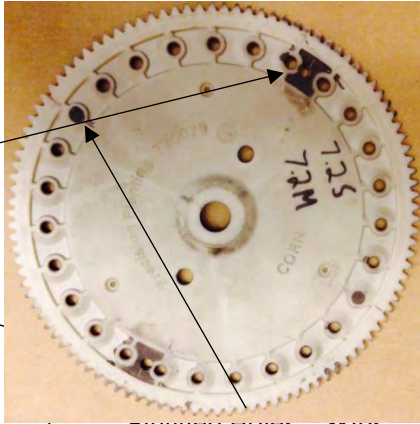

Plugged holes = skips

Results: The table below illustrates 95% seed singulation resulted in economic losses of **-\$41.00/A.** over a 5-yr period of 2018-2022.

Over this same time period, for each percentage of singulation lost, yield was decreased by an average of **-2.1 Bu/A.**

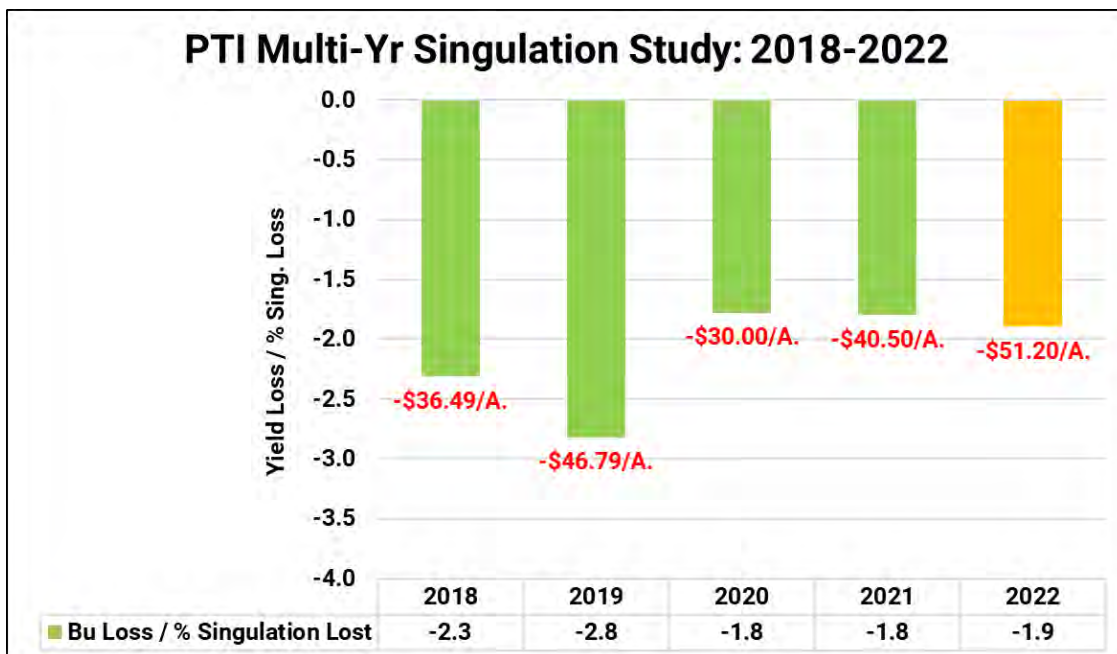

Manual Corn Planting Depth Study

Objective: To evaluate yield and economic performance of various manual corn planting depths consisting of 1" to 2.75" in ¼" increments.

Results: Tables 1-2. reveal that shallowing up planting depths to 1" to 1.25" resulted in yield losses of **-19.6** to **-30.6 Bu/A**. Figure 1. illustrates stand losses due to the shallow planting. These stand losses resulted in significant economic losses of **-\$117** to **-\$183/A**.

Optimum planting depth occurred at 1.75", while 1.5" and 2" depths resulted in yield losses of **-2.2** to **-5.1 Bu/A**. with associated economic losses of **-\$13** to **-\$30/A**.

As planting depth was increased to 2.25" to 2.75", yield was consistent with yield decreases of **-5.8** to **-6.5 Bu/A**. and with lower revenue of **-\$33** to **-\$39/A**.

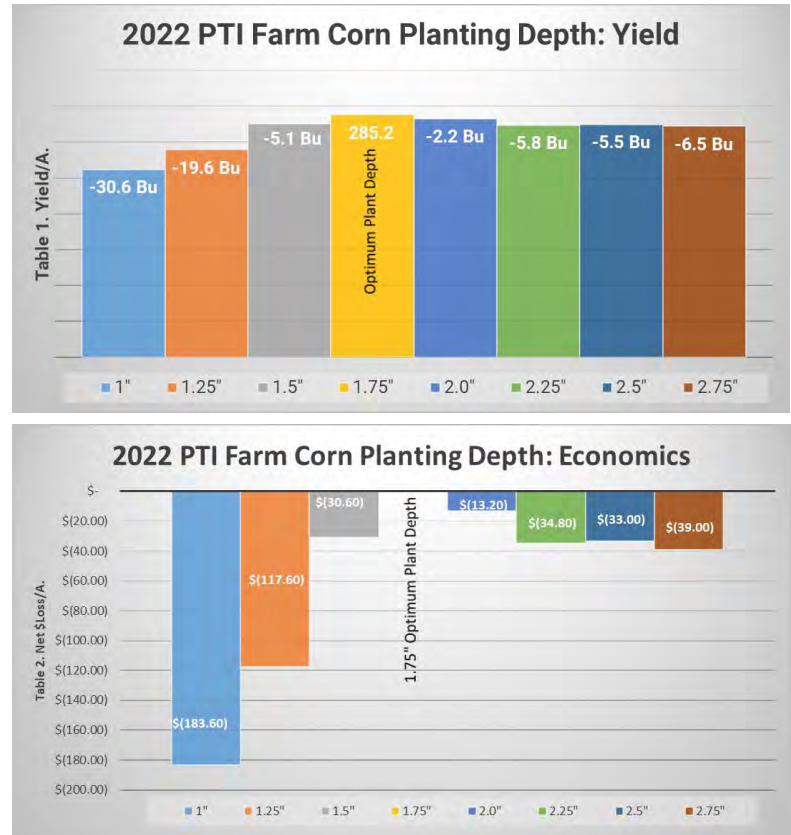

Figure 1. Emergence by Planting Depth



Planting Date: 5/2

Hybrid: DK 66-17

Population: 36K

Row Width: 30"

Rotation: CAB

Corn Price: \$6.00

SmartDepth® Corn Planting Depth Study

Objective: To evaluate yield and economic performance of various manual corn planting depths consisting of 1" to 2.75" in ¼" increments, compared to automated variable depth planting using SmartDepth® control.

Digging seeds is a time consuming yet important task at planting time (Figure 1). Getting your eyes on the furrow where the seeds are placed, will allow you to understand if those seeds are in an environment to thrive. Is the seed being planted into adequate moisture? Until now, we didn't know this for every seed, and we were unfortunately simply guessing.

With a SmartFirmer® sensor (Figure 2.) you can now have virtual eyes in the furrow. Soil moisture is a critical component for seed germination, uniform plant emergence, and ultimately crop yield. SmartFirmer® sensors gives row-by-row visibility to soil moisture in the seed furrow, allowing farmers to choose the right planting depth as soil conditions change. Currently, the recommendation for ideal furrow moisture levels to achieve adequate corn emergence, is near 32%. Using the 20|20® monitor (Figure 3.) in tandem with SmartFirmer® sensors, we now have the ability to evaluate furrow moisture in real-time. Based on this real-time information, growers can make decisions based on live sensing data.

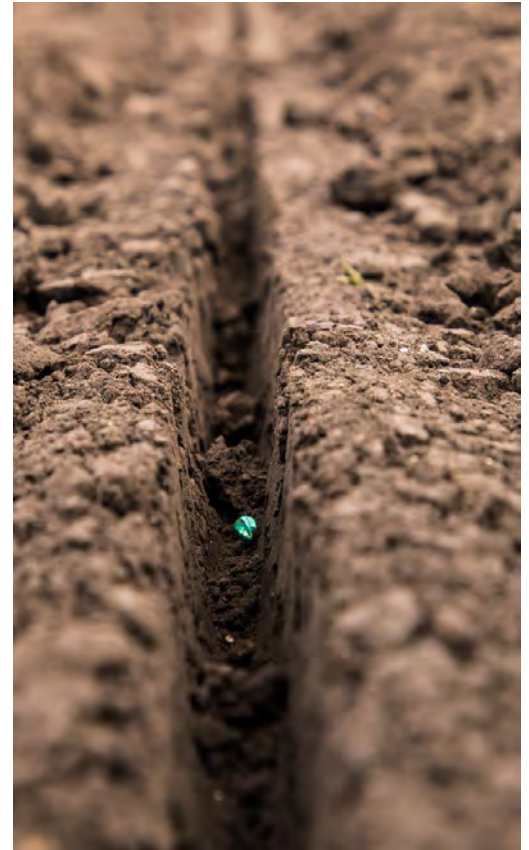

Figure 1. Seed Furrow

Figure 3. 20|20® Monitor System



Figure 2. SmartFirmer® Sensor

SmartDepth® Corn Planting Depth Study Continued

Figure 4. illustrates SmartDepth®, a unique product that takes the technology one additional step further, allowing planting depth to be changed on a planter, by section or individual row basis. This can be done manually from the tractor cab and 20|20® console, or automatically using furrow moisture values from SmartFirmer® sensors. Growers can customize their own settings to optimize both furrow moisture and planting depth values (Figure 5). This control allows growers to measure, react, and take control of planting depth to optimize emergence timing.

Figure 5. SmartDepth® Customization Screen



Figure 4. SmartDepth® Control System



SmartDepth® Corn Planting Depth Study Continued

Results: Tables 1-2. reveal that SmartDepth® achieved corn yield within 0.7 Bu/A. of the optimum planting depth of 1.75" and economic variance of only \$4.20/A.

The telling story in this study is furrow moisture levels. Table 3. illustrates average furrow moisture of 37.6% Currently, the recommendation for ideal furrow moisture levels to achieve adequate corn emergence, is near 32%. Table 3. indicates all planter rows, except Row 1, averaged over 32% levels. This indicated good field moisture and deep planting depths were not needed. When planting depths were increased, Table 1. summarizes yield losses of **-2.2 to -6.5 Bu/A.**

By using SmartDepth®, SmartFirmer® and a 20|20® monitor system, growers can obtain perfect planting depths just below the furrow moisture line.

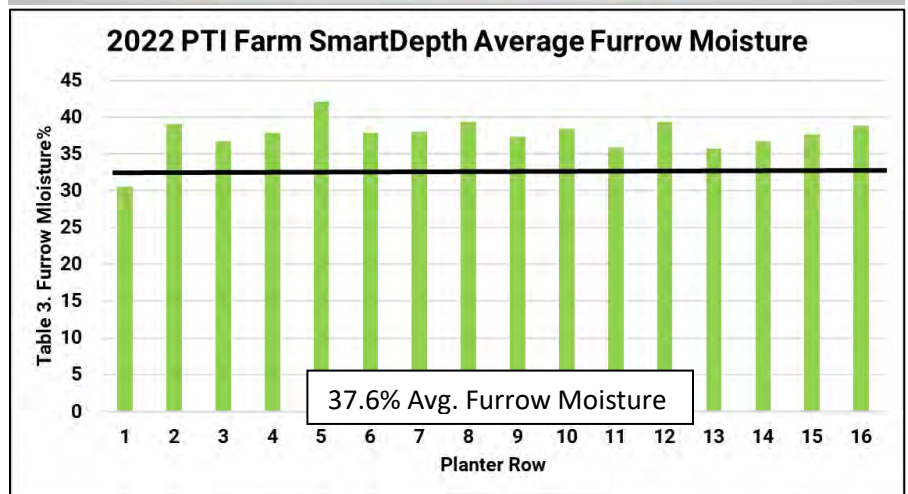
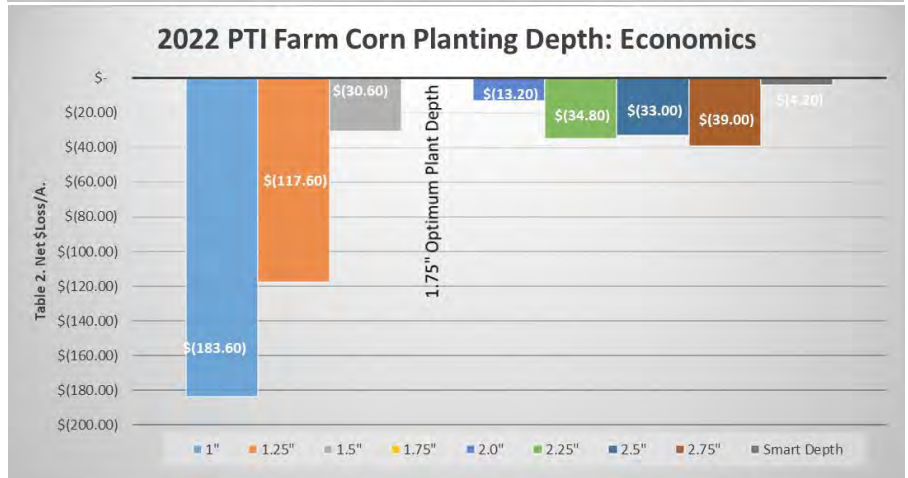
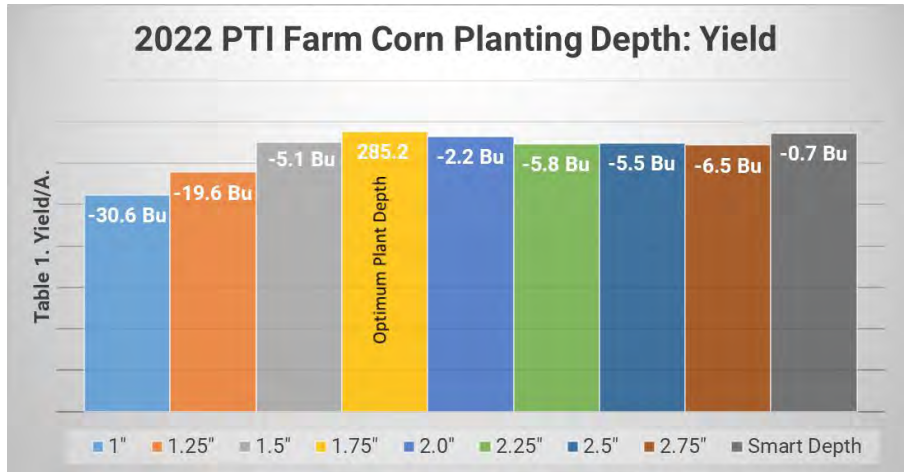

Keeton® Seed Firmer Study

Objective: This study evaluates the benefits of Keeton® Seed Firmers (Figure 1). Seeds don't always land right in the bottom of the trench where they belong. With its unique, in-the-trench design, the Keeton® Seed Firmer gently firms those seeds to the bottom of the V-trench (Figure 2). The result is even depth, correct seed-to-soil contact, and most importantly, uniform germination.

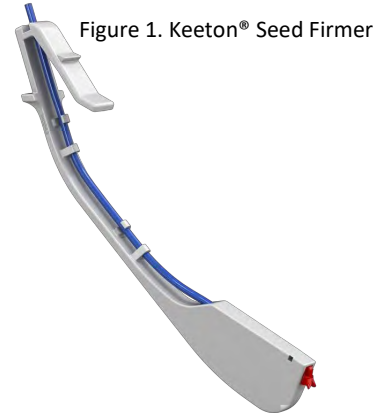
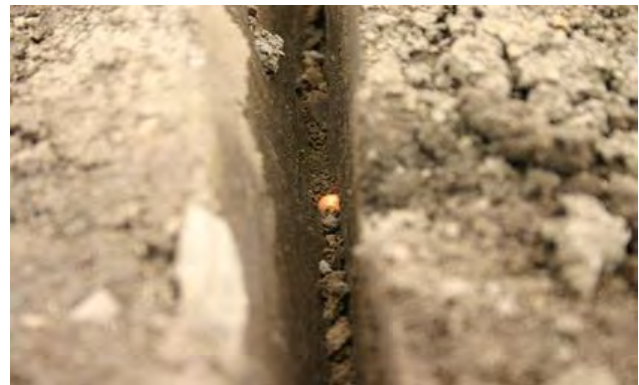

Figure 1. Keeton® Seed Firmer

Results: Table 1. illustrates multi-year yield data over the time period of 2018 – 2022 at the PTI Farm. The presence of Keeton® Seed Firmers resulted in average yield gains of +2.9 Bu/A. As for economics, this yield gain equates to additional economic gains of +\$12.82/A. compared to not using a seed firmer.

Figure 2. Good Seed-to-Soil Contact from Keeton® Firmer



At a cost of \$35/row for Keeton® Seed Firmers and quick attach brackets for a 16-row planter, using the +\$12.82/A. increase in revenue, break-even occurs at only 44 acres.

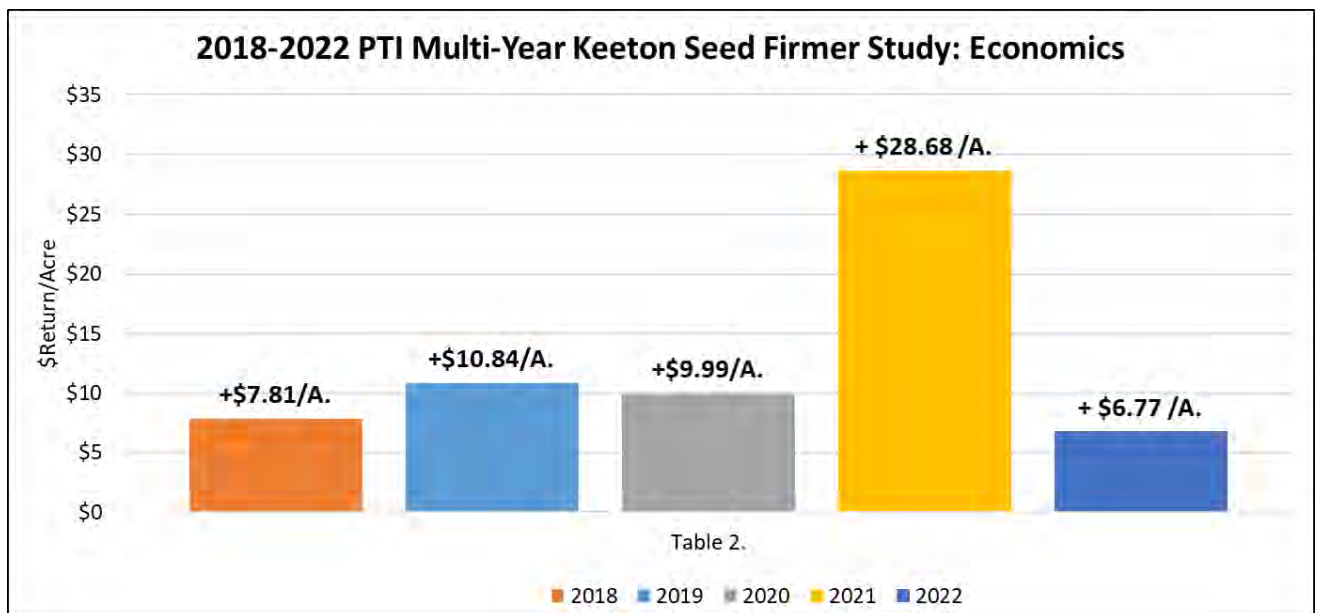

STP Opening Disc Study

Objective: This study evaluates the use of 3 different types of opening discs from Prescription Tillage Technology L.L.C.



STV STANDARD TRUE V

Standard True "V" Blade with Anti-Stubbing or Dulling Technology

- Shallow and full planting depth
- Sharp gravel and shale rock conditions
- Standard soils and planting conditions
- Standard and offset true-V planter configurations
- Available with off-set blade configurations on standard planters
- Fits John Deere, Kinze, Harvest International, Horsch, Monosem, White and Precision



STP SABRE TOOTH PLANTER

True "V" & Single Blade Applications

- 1" minimum to full planting depth
- Challenging soil and planting conditions
- Challenging residue conditions
- Standard planter configurations
- Enhances early and late root development
- 14.75" inside with 15" outside combination fits John Deere, Kinze, Harvest International, Horsch, Monosem and older White
- 15.75" inside with 16" outside combination fits newer White and Precision



STPS SABRE TOOTH PLANTER SHALLOW FILLET

Shallow Planting Sharp Gravel & Shale Rock Conditions

- Shallow and full planting depth for cotton, canola, and shallow seed placement requirements
- Sharp gravel and rock conditions
- Challenging soils and planting conditions
- Enhances early and late root development
- .100 cut out
- 15" inside with 15" outside combination fits John Deere, Kinze, Harvest International, Horsch, Monosem and older White
- 16" inside with 16" outside combination fits newer White and Precision



Opening Disc Study Continued

Results: Table 1. Illustrates each of the Prescription Tillage Technology’s opening discs performance. Compared to the STV smooth discs as the control in this study, the STPS mild discs realized a **-4.9 Bu/A.** loss, while the aggressive STP discs reduced yield by **-4.7 Bu/A.**

This was our 2nd year of testing these opening discs. Table 2. reflects the 2021 and 2022 growing seasons with both the mild and aggressive averaging losses of **-0.6 to -1.5 Bu/A.** respectively.

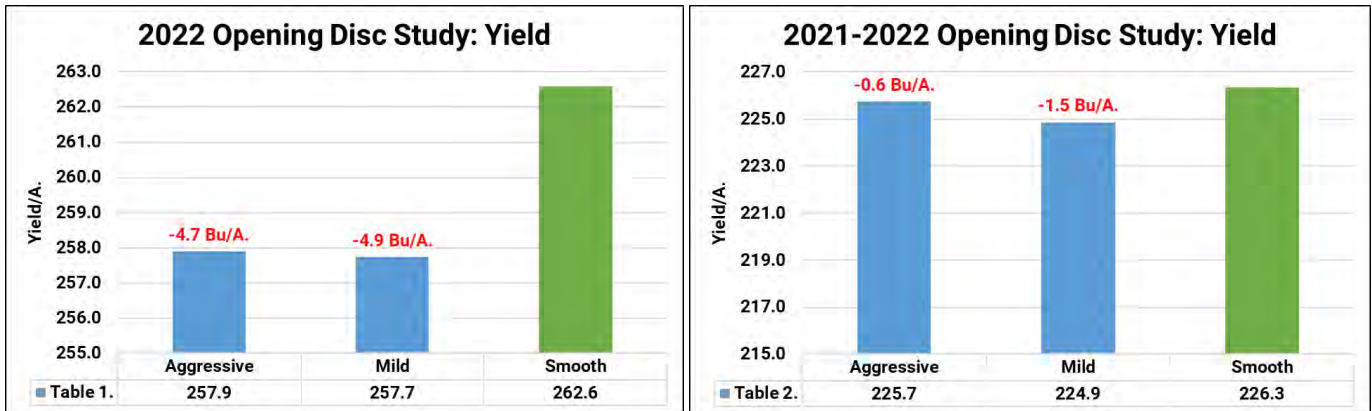

STP disc installed on Harvest International® planter



“U” Furrow created by STP



True “V” created by standard opener discs

Planting Date: 5/12

Hybrid: GH 15J91

Population: 36k

Row Width: 30"

Rotation: CAB

Corn Price: \$6.00

Reveal® Residue Management Study

Objective: This study evaluates the yield and economic benefit of Reveal®, a frame mounted row cleaner system in a corn after corn strip-till environment.

Residue management is a necessary part of today's operation to maximize profitability. Tougher stalks and more corn-on-corn acres mean a heavier load of residue that needs to be controlled. Residue in the seed trench competes with seedlings for moisture and can harbor diseases.

Reveal® (Figure 1-2.) is frame mounted, so unlike other row cleaners, it gets rid of that row unit chatter. It has an internal gauge wheel that precisely controls the depth of the cleaning tines. It also has an airbag that makes sure the depth that it's set at, stays consistent. The pressure of the airbag can be controlled on the 20|20® monitor or utilizing a manual controller in the cab.

Figure 1. Reveal® System



In this agronomic study, we compared the absence of row cleaners, floating row cleaners, and CleanSweep® at 20-30# lift (Control in study), to that of Reveal® at the following notch and PSI settings:

1. Reveal® Notch1 10# Down
2. Reveal® Notch2 10# Down
3. Reveal® Notch1 20# Down
4. Reveal® Notch 2 20# Down
5. Reveal® Notch 1 30# Down
6. Reveal® Notch 2 30# Down

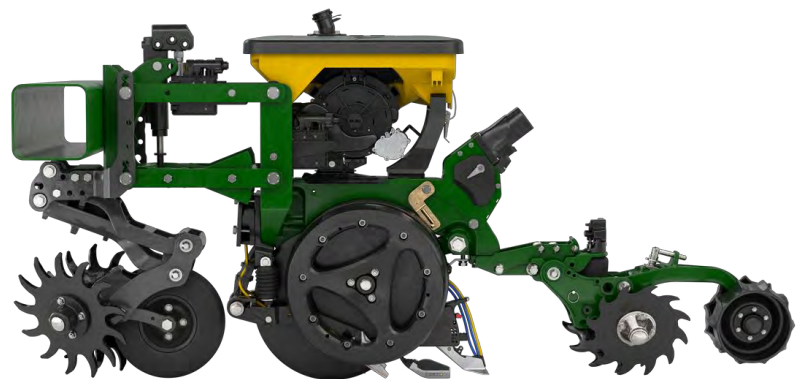

Figure 2. 20|20® System

Reveal® Residue Management Study Continued

Results: Table 1. illustrates the summary of all residue manager systems.

Compared to the control of CleanSweep® at 30# PSI lift, the Reveal® residue management system at 10# PSI down in both notch 1 and notch 2 wheel settings, provided the highest yield gains in the study. with gains of +4.1 to +6.3 Bu/A.

Reveal® in general, provided +3.1 to +5.2 average yield gains at the 10# and 20# PSI down setting. However, as PSI increased to 30#, yield response fell to losses of **-2.6 to -5.8 Bu/A.** to CleanSweep® 30# lift.

100% lift (no residue managers) realized **-4.5 Bu/A.** losses to that of the control and **-10.8 Bu/A.** losses compared Reveal® at 10#PSI in notch 1 position.



Figure 3. Reveal® System



Figure 4. Reveal® Depth Adjustment in Notch 1

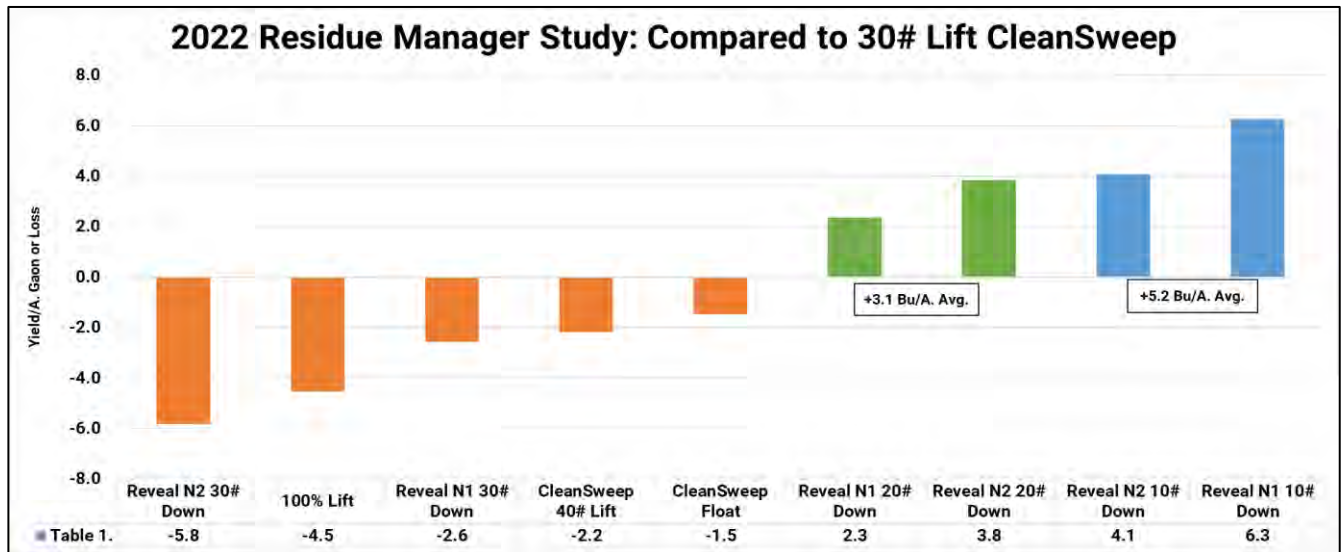

Planting Date: 5/13 Hybrid: DKC 66-17 Tillage: Conv Population: 36K Row Width: 30" Rotation: CAB Corn Price: \$6.00

CleanSweep® Residue Management Study

Objective: This study evaluates the benefits of planter row cleaners equipped with CleanSweep® cylinders. Residue management has become a necessary part of today’s operation to maximize profitability. Tougher stalks and more corn-on-corn acres mean a heavier load of residue that needs to be controlled. Residue in the seed trench competes with seedlings for moisture and harbors disease. CleanSweep® cylinders puts row cleaners right where they need to be, moving residue but not the soil. Continuous adjustments can be made as field conditions change with the cab-mounted controller to easily lift or make more aggressive adjustments.

In this study, we use air pressure to adjust CleanSweep® cylinder settings on Yetter 2967 spike row cleaners to allow the ability to change and evaluate the aggressiveness of row cleaners. These settings were then evaluated to study yield and economic advantages.

These agronomic settings consisted of:

1. Lifting the row cleaners 100% to simulate the lack of row cleaners.
2. A “floating” (0# psi) position that allows the row cleaner to ride along top of the soil surface with no air control, lift, or down-pressure.
3. 20# of air down-pressure, just aggressive enough to wipe crop residue and clods out of the way to lead a clean path ahead of the planter gauge wheels and seed disc openers.

Figure 1. CleanSweep®

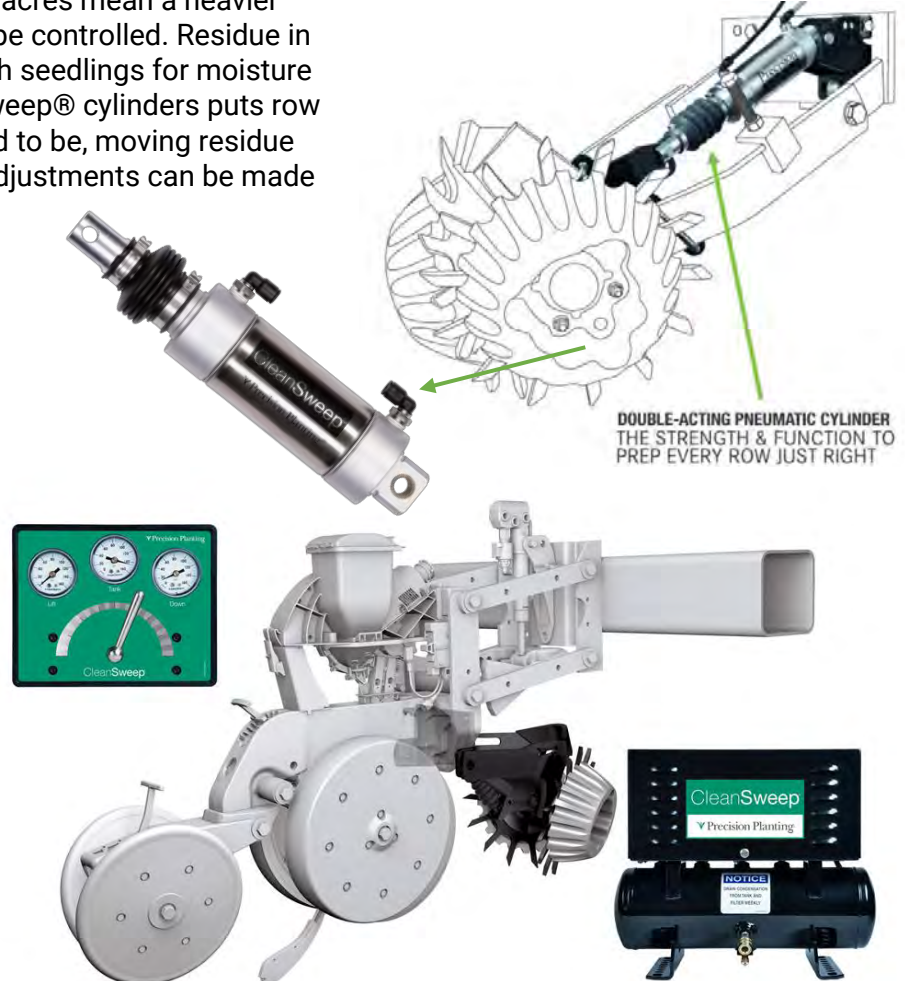

CleanSweep® Residue Management Study Continued

Results: Table 1. illustrates CleanSweep® cylinder yield results from the PTI Farm in 2022. Row cleaners provided a yield benefit of +4.2 Bu/A, compared to the 100% lift setting of no row cleaners. Floating row cleaners proved losses of **-1.0 Bu/A.** compared to the more aggressive grower setting of 20#psi down.

Figure 2. Yetter Row Cleaners with CleanSweep®



Tables 2-3 summarize multi-year average yield and economic gains from CleanSweep® cylinders during the growing seasons of 2018-2022. During this time-period, row cleaners equipped with CleanSweep® cylinders at 20#psi down realized +8.3 Bu/A. yield gains compared to using no row cleaners. These gains resulted in gross revenue increases of +\$33.41/A.

This same 20#psi down setting also improved yields over the 0# float position by +2.4 Bu/A. and consequently improved revenue by +\$9.45/A.

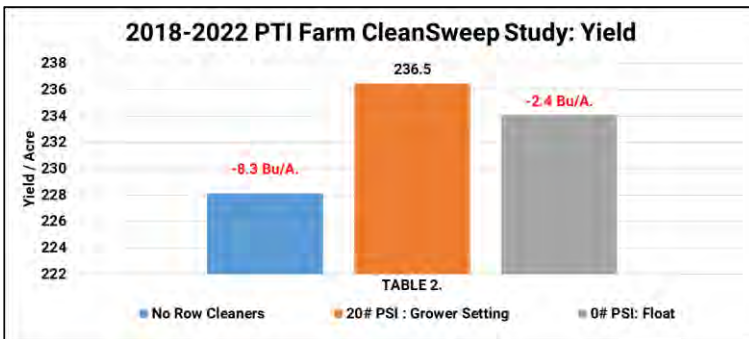
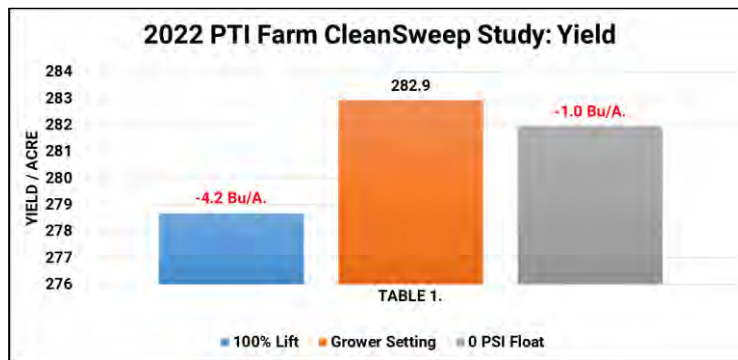

2022 Day of Emergence Study

Objective: This study evaluates the impact of yield loss when corn plants emerge from the soil surface on an inconsistent basis. 12-hour flag testing was implemented to monitor the emergence timing of young plants. As corn first started to emerge from the soil surface, flags were placed at five different timings to identify the emergence of all plants within the study (Figures 1-2).

Figure 1. 24-hour Late Emerging Plant



Figure 2. 12-Hour Flag Testing



Protocol:

- 12 hours =** 1st initial plants to emerge
- 24 hours =** Plants that emerged 24 hours later
- 36 hours =** Plants that emerged 36 hours later
- 48 hours =** Plants that emerged 48 hours later
- 48+hours=** Plants that emerged >48 hours later

Results: Table 1. illustrates the occurrence factors of emergence timing at each 12-hour interval. 78% of all plants did in fact emerge in the first 12-hour time-period. Plants that emerged just 12-hours later in the 24-hour time-period totaled 14.5% occurrence, while 36-hours tallied 3.8%, 48-hours 2.9% and 48+hours tallied 0.7%.

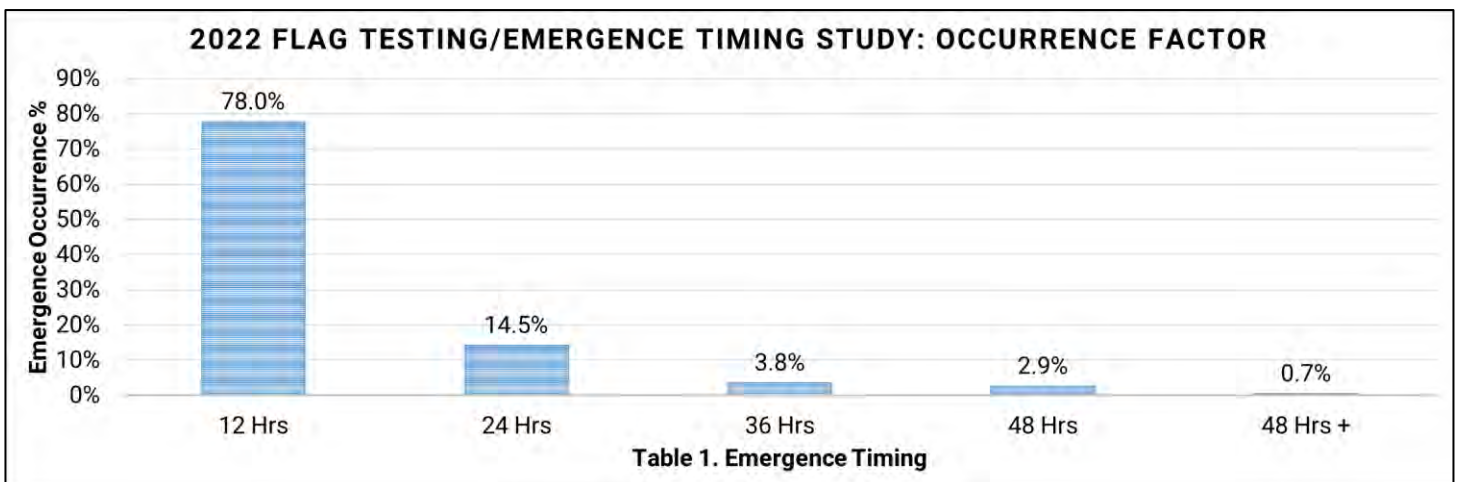

2022 Day of Emergence Study Continued

Table 2. reveals the yield losses from each occurrence factor from Table 1. Using 12-hour emergence as the ideal baseline control, yield decrease was documented as the following:



- **-10%** yield losses at the 24-hr emergence timing
- **-50%** at the 36-hour emergence timing
- **-92%** at the 48-hr emergence timing
- **-91%** at the >48-hour emergence timing.

Pictured to the left is an ear board display of corn ears collected from this 2022 study at each emergence timing interval. The entire top row represents the baseline of 12-hour emergence. As each 12-hour emergence occurs, the ear board displays the ear size and yield loss associated from emerging late and competing with surrounding plants for water, nutrition, and sunlight.

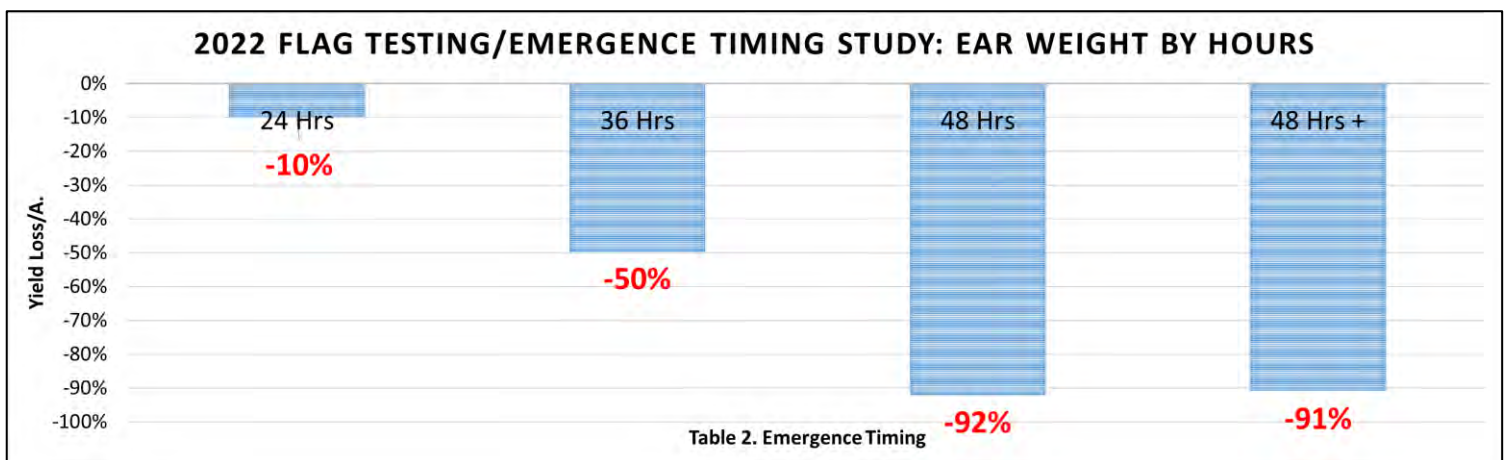

2022 Day of Emergence Study Continued

To help explain this, Table 3. illustrates the average overall revenue loss from all closing systems. Corn that emerged just 12-hours later (24-hour emergence) resulted in revenue losses of **-\$17.57/A.**, 36-hour emergers resulted in losses of **-\$23.12/A.**, the 48-hour emergence timing at **-\$32.16/A.** and +48-hour late emergers at **-\$7.53/A.** As a result, the overall highest corn yield loss occurred at the 48-hour emergence timing.

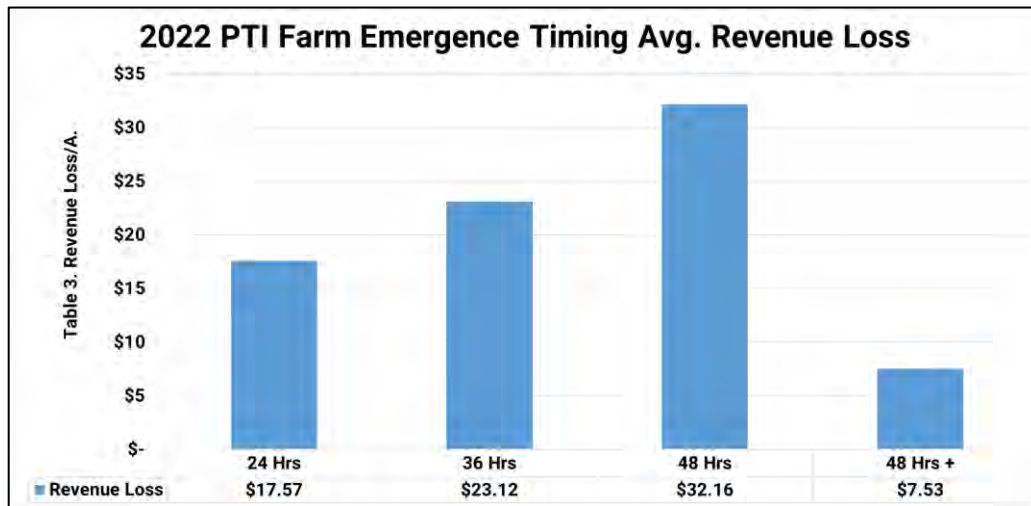

In summary, uniform emergence is critical to maximize corn yield. Any delay of emergence can be significant in reducing ear size and weight and ultimately corn yield. We encourage growers to conduct flag testing/emergence timing studies to monitor individual performance in your fields. Contact your local Precision Planting Premier Dealer for free flag test emergence kits for the 2023 spring season.

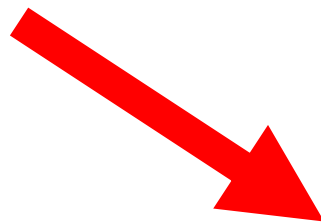

Multi-Year Day of Emergence Study

Objective: This multi-year study illustrates the impact of yield loss when corn plants emerge from the soil surface on an inconsistent basis. Flag testing implementation (Figure 1.) was used to monitor the emergence timing of young plants each year. As corn first started to emerge from the soil surface, flags were placed at five different timings to identify the emergence of all plants within the study.

Figure 1.



Protocol:

- 12 hours =** 1st initial plants to emerge
- 24 hours =** Plants that emerged 24 hours later
- 36 hours =** Plants that emerged 36 hours later
- 48 hours =** Plants that emerged 48 hours later
- 48+hours=** Plants that emerged >48 hours later

Results: Manual ear checks were completed to calculate potential yield loss from late emerging plants. Table 1. below summarizes yield loss as emergence varied over the 3-year study. Plants that emerge in the first 12 hours are considered the best achievable performance and therefore used as the baseline control with 100% yield potential. As plants emerged 24 hours later, **-9%** yield losses were realized compared to the first emergers. As emergence continued to 36-hour delay, yield fell to **-38%** losses. 48-hour delay in emergence resulted in yield deficits of **-83%** and finally, the latest emergers that came up >48-hours proved devastating losses of **-90%**

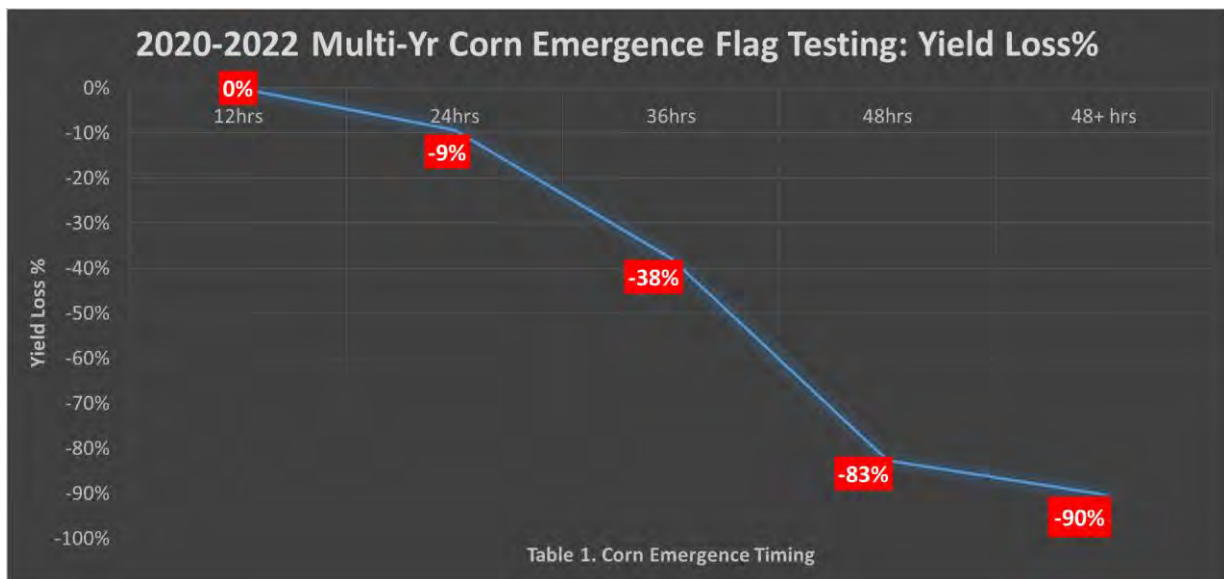

Planting Date: May 15th Hybrid: DK 65-95 Population: 34K Row Width: 30" Rotation: CAB Corn Price: \$6.00

SpeedTube® Corn High Speed Planting Study

Objective: To evaluate yield response of planting speeds of 4, 6, 8, and 10 MPH with a SpeedTube® system. This high-speed planting technology takes the place of conventional seed tubes and consists of a flighted belt. By transporting each seed to the furrow, there is no opportunity for seeds to ricochet into the trench. Even at twice normal planting speeds, seed arrives safely at the bottom of the trench, spaced evenly, every time.



Results: Table 1. illustrates corn yield from planting speeds of 4 to 10 MPH only varied 2.6 Bu/A. between all speed intervals.

Table 2. summarizes multi-year data from 2018-2022, with SpeedTube® only varying 2.3 Bu/A.

With traditional planting speeds typically near 5 mph, this data would suggest that growers could plant twice as fast without sacrificing planter performance.

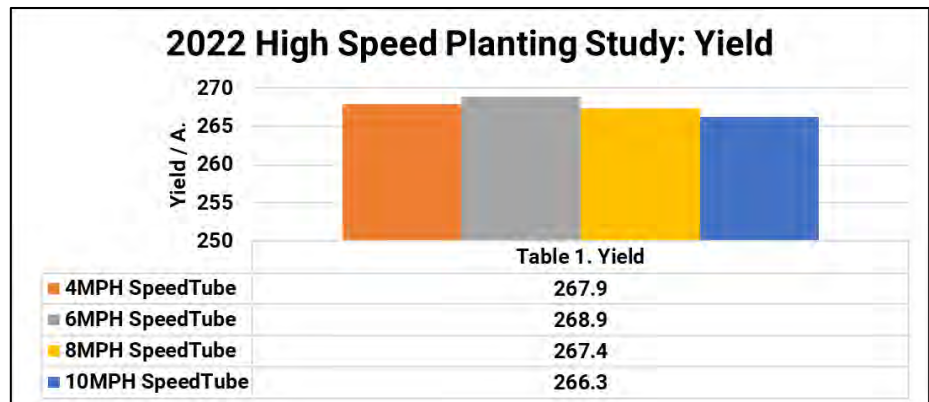

WaveVision® SeedTube Corn High Speed Planting Study

Objective: To evaluate yield response of planting speeds of 5 and 10 MPH with a WaveVision® Seed tube system. Seed tubes are designed for typical planting speeds of 4 to 6 MPH.

Figure 1. WaveVision® SeedTube

WaveVision® is a seed sensor within the seed tube that counts only seeds and not dust, giving you confidence that the population you see on your monitor is the population that you're planting. WaveVision® does not incorporate an optical sensor in the housing, meaning there is no opportunity for seeds to ricochet into the trench. Instead, high-frequency radio waves measure mass instead of shape.

Results: Table 1. illustrates seed tube performance fell by **-11.1 Bu/A.** when increasing planting speed from 5MPH to 10MPH, resulting in losses of **-\$66.60/A.** Conversely, Table 1. also verifies that if a grower chooses a SpeedTube® high speed planting system, yield varied by only 0.47 Bu/A. from traditional 5MPH seed tube applications.

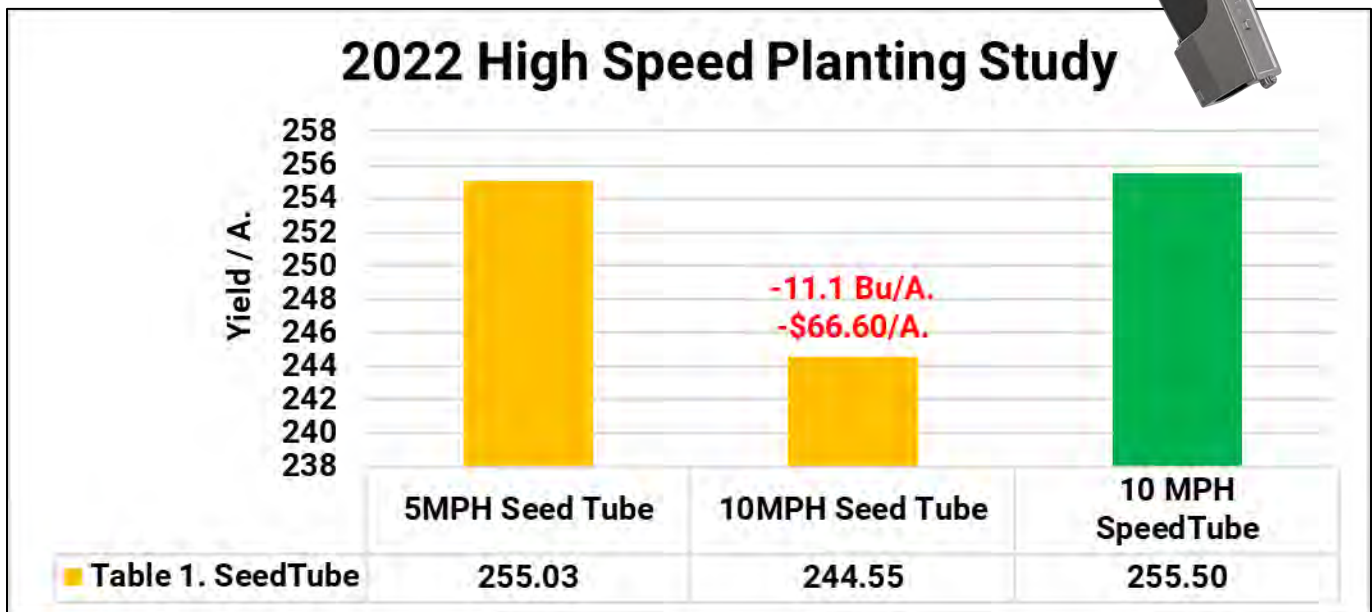

Corn Tillage/Closing Wheel Study

Objective: To evaluate the performance of non-sensing single-stage and two-stage automatic sensing closing systems in four different tillage practices including conventional, strip, vertical, and no-till.

Closing systems are designed to close the seed trench, eliminate sidewall smear, compaction and to remove air pockets, all while achieving good seed-to-soil contact.

Two Goals of Proper Closing

1. Remove Air Pockets
2. Lift and Fracture Side-Walls

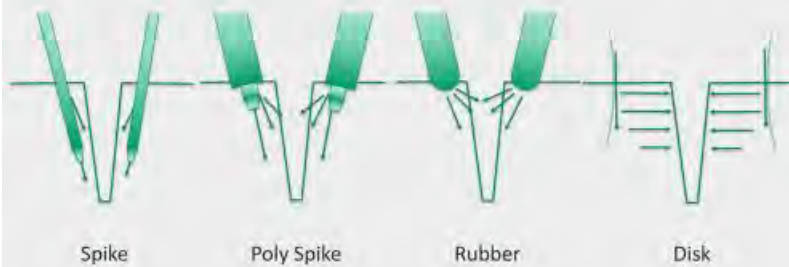

Figure 1. Air Pocket Causing Poor Seed to Soil Contact



Figure 2. Good Seed to Soil Contact

Corn Tillage/Closing Wheel Study Continued

This tillage/closing study evaluates yield and economics of five distinctly different types of closing wheel systems, in four different tillage systems including the following:



FurrowForce® Closing and Sensing Control System:

Advantages: Lifts and fractures sidewall compaction/smear
2nd stage stitching and removal of air pocket
Automatic sensing/control of soil variability

Disadvantages: Rocks can be problematic, increased cost



Non-Sensing Traditional Dual Rubber Closing System:

Advantages: Sealing or "Pinching" in dry conditions

Disadvantages: Difficult to lift/fracture sidewalls, struggles to close furrow



Non-Sensing Dual Yetter Poly Twister® Closing System:

Advantages: Lifts and fractures sidewall compaction/smear
Center ring acts as depth maintainer

Disadvantages: Lightweight wheels require increased tension



Non-Sensing 360 Wave™ Closing System:

Advantages: Rolls a wave of moist soil over seed to prevent drying out

Disadvantages: Only addresses one side of furrow.



Non-Sensing Integrated Ag Solutions "The Closer" System:

Advantages: Swept back design destroys sidewall compaction
Poly wheels are corrosion resistant

Disadvantages: Lighter weight wheels may require increased tension

Corn Tillage/Closing Wheel Study Continued

Four tillage systems were evaluated in the study to evaluate the difference in closing performance.

Vertical-Till (Figure 1.) In the fall after harvest, vertical tillage was used to mix, cut, and level residue in a 3" depth tillage pass. Herbicide was used as a burndown to control early season weeds in the absence of spring tillage.

No-Till: (Figure 2.) Planting directly into last year's corn stalks with no tillage activity performed. Herbicide was used as a burndown to control early season weeds in the absence of tillage.

Conventional-Till (Figure 3.) In the fall after harvest, deep 13" ripping with aggressive cutting and mixing of residue. A spring soil finisher leveled before planting.

Strip-Till (Figure 4.) In the fall after harvest, 10" deep strips were created with a strip-till unit. Herbicide was used as a burndown to control early season weeds in the absence of spring tillage.

Figure 1. Sunflower® 6833 Vertical-Tillage Tool



Figure 2. No-Till Planter



Figure 3. Sunflower® 4630 Disc-Ripper



Figure 4. Kuhn® Krause® 1200 Gladiator® w/ Montag® Fertilizer Cart



Corn Tillage/Closing Wheel Study Continued

Results:

Conventional Till: Minimal yield variance occurred within all closing systems with a spread of only 4.4 Bu/A. Dual Yetter Twister® wheels and the dual Closer outperformed FurrowForce® by +1.6 to +2.7 Bu/A. respectively in this looser and mellow type soil environment, equating to revenue gains of +\$9.60 to +\$16.20/A.

Vertical-Till: FurrowForce® proved positive yield gains compared to all other closing systems by +5.2 to +10.1 Bu/A. In this difficult to close planting environment, dual traditional rubbers proved highest yield losses of **-10.1 Bu/A.** with revenue losses of **-\$60.60/A.** All other closing systems resulted in revenue losses of **-\$31.20 to -\$41.40/A.**

Strip-Till: Small yield range of only 1.6 Bu/A. between all systems. All closing systems performed similarly in this tillage system with revenue variance of **-\$4.20 to -\$9.60/A.**

No-Till: FurrowForce® outperformed all closing systems with yield gains of +4.1 to +8.4 Bu/A. In this tougher to close type environment, all closing systems suffered, however dual traditional rubbers and the 360 Wave™ provided the largest discrepancy with yield losses of **-7.1** and **-8.4 Bu/A.** with economic losses of **-\$42.60 to -\$50.40/A.**

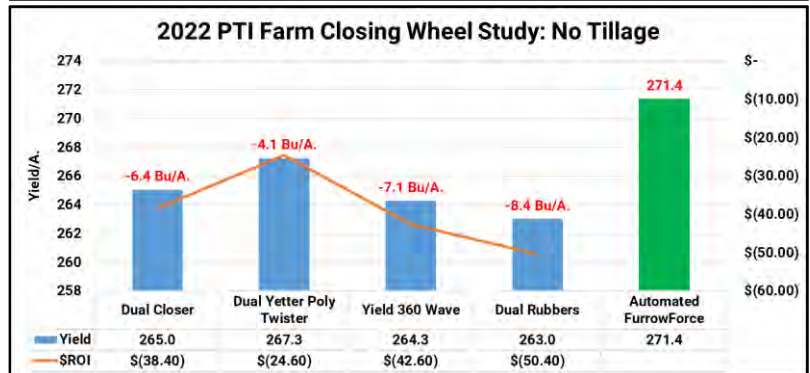
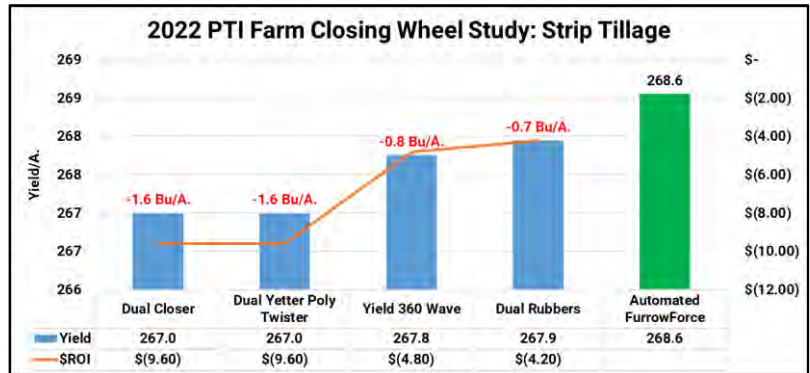
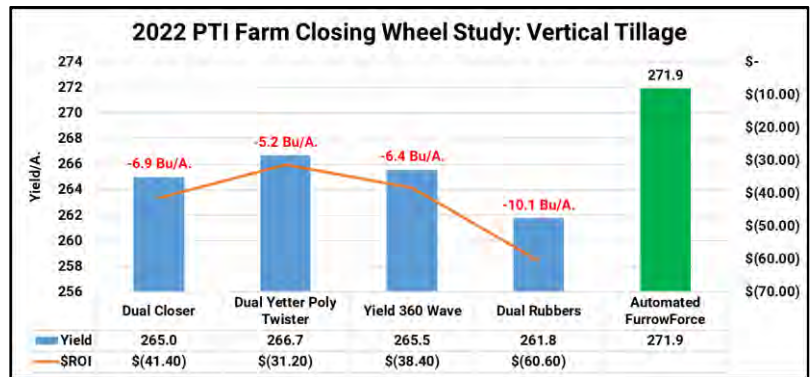
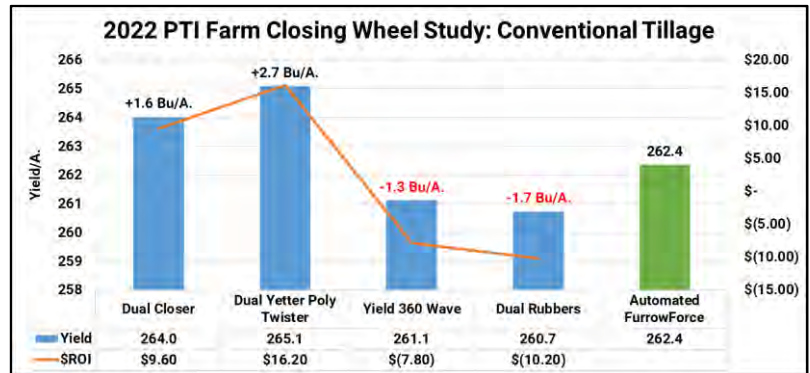

Corn Closing Wheel Study Continued

Overall, FurrowForce® two-stage automatic closing resulted in average yield gains of +3.63 Bu/A. and additional revenue of +\$21.75/A. across all tillage environments.

However, the clear advantage for FurrowForce® occurred in reduced tillage environments such as no-till and vertical tillage. In these programs, yield gains of up to +8.4 to +10.1 Bu/A. with increased revenue of +\$50.40 to +\$60.60/A. clearly indicate that in tougher closing situations, a more robust system is needed to effectively close the furrow.

In summary, for years planters have struggled with closing systems with manual settings that offered the inability to account for and change for varying soil conditions. Today, we are excited that technology finally exists where farmers can use sensing technology on the planter row unit to determine how much force is needed on closing systems to address soil variability. By using a robust 2-stage closing system, load pin and sensing architecture, partnered with a 20|20® monitor, farmers can be confident of closing the seed trench, eliminating sidewall compaction/smearing, and removing air pockets all while planting through various seedbed conditions on a pass-pass basis.

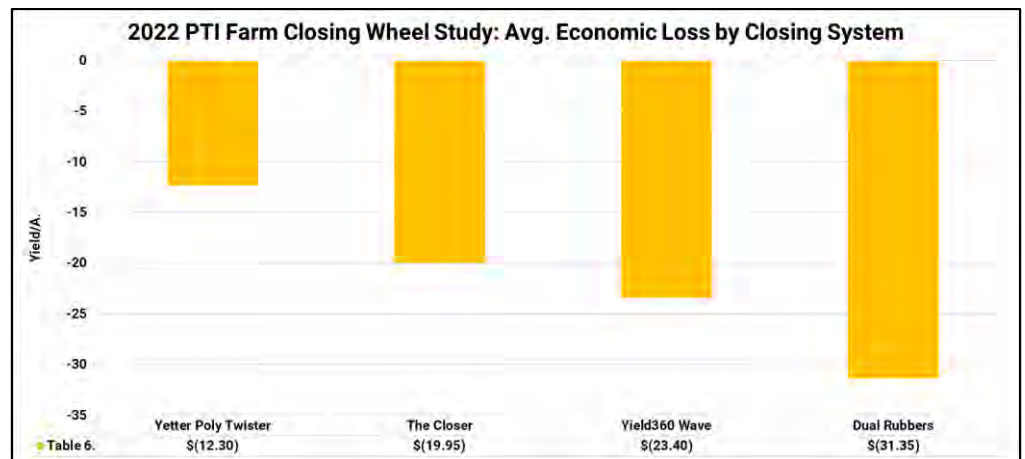
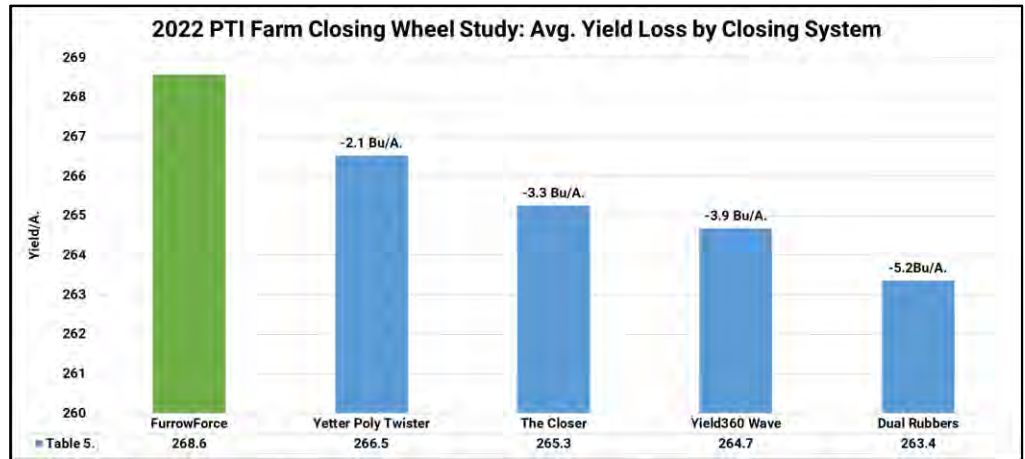

DownForce Management Study

Objective: Planter row unit downforce is a common agronomic issue that often goes unaddressed. This study evaluates yield impact of implementing proper downforce, compared to too light or too heavy row unit settings. When downforce matches field conditions, the depth of planting is consistent and correct. Too light of row unit downforce causes planting depth to shallow up, potentially placing seed in dry soil, thus creating poorly rooted plants that struggle for water and nutrients. Conversely, too much downforce can lead to furrow side-wall compaction also creating an environment that can cause limited plant access to water and nutrients.

DeltaForce® system replaces the springs or air bags on your planter with hydraulic cylinders (Figure 1.) It automatically increases or decreases weight with military precision, on each row individually. When one row encounters conditions different than another (wheel tracks, old roadbeds, clay knobs, headlands, etc.), each will adjust independently (Figure 2). Row by row, foot by foot, and seed by seed, you produce an environment that fosters uniform germination, optimum growth, and maximum yield.

Figure 1. DeltaForce® Cylinder



Figure 2.

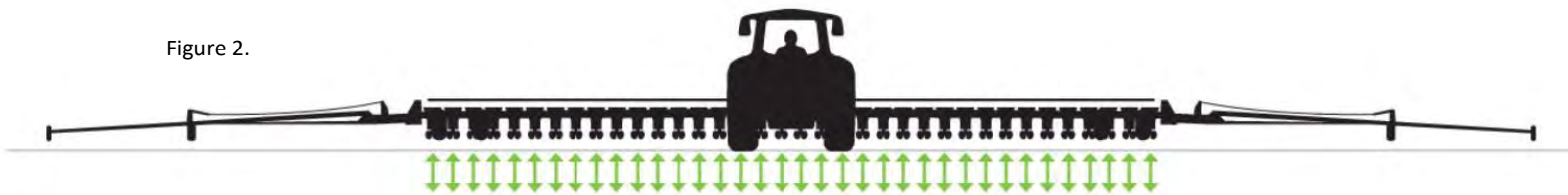

DownForce Management Study Continued

Results: Table 1. illustrates the yield response of DeltaForce® automated control (Custom 120#) compared to excessive and light downforce settings. Too light of downforce (175# lift, 100# down) resulted in yield decreases of **-7.2 Bu/A.**, while excess downforce (550# down, 100# up) offered the largest yield losses of **-6.6 Bu/A.**

Table 2. reveals the economics of the automated downforce system. Light downforce suffered the largest overall losses of **-\$43.08/A.**, while excess downforce resulted in a loss of **-\$39.47/A.**

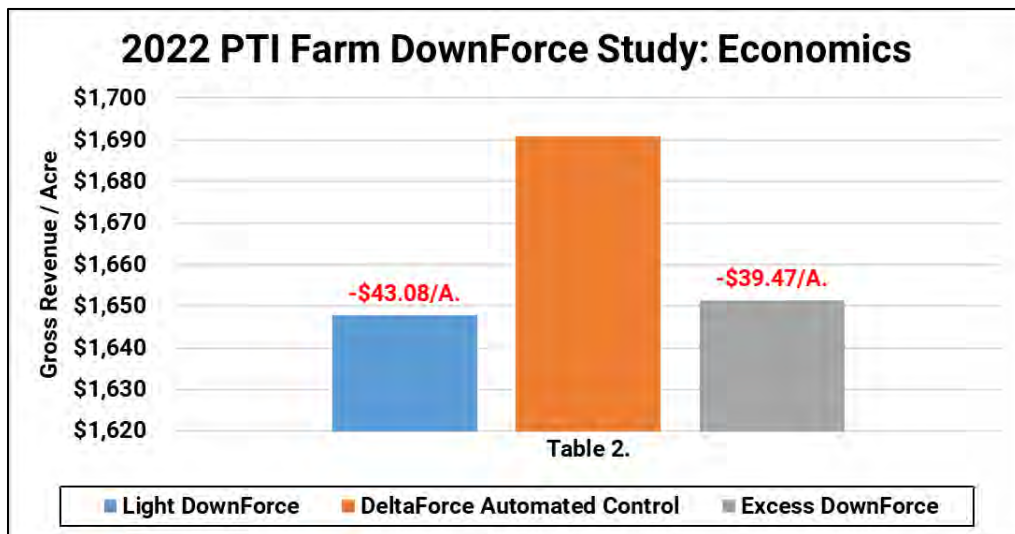
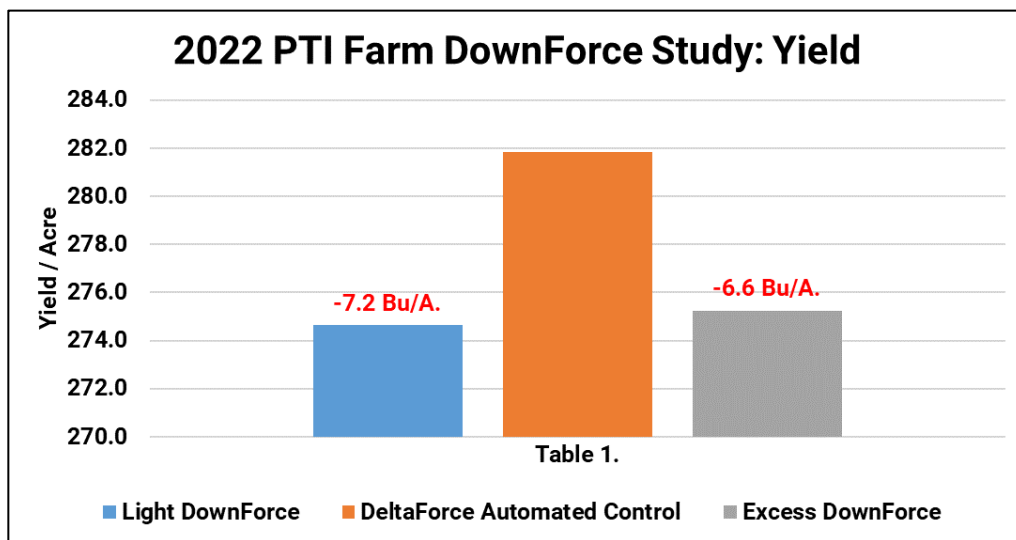

DownForce Management Study Continued

Table 3. illustrates multi-year downforce yield results over the time-period of 2018 to 2022 at the Precision Planting PTI Farm. During these growing seasons, light downforce resulted in yield losses of **-13.5 Bu/A.** compared to automated control with a DeltaForce® system. Excess downforce resulted in losses as well, however at only **-7.0 Bu/A.**

Table 4. depicts the same multi-year time-period, but economics rather than yield. Over 2018-2022, light downforce resulted in economic losses of **-\$54.17/A.** and excess downforce of **-\$31.18/A.**

In summary, when downforce matches field conditions, the depth of planting is consistent and correct. By measuring with the DeltaForce® system, farmers can react and take control to ensure proper downforce and eliminate yield and economic losses.

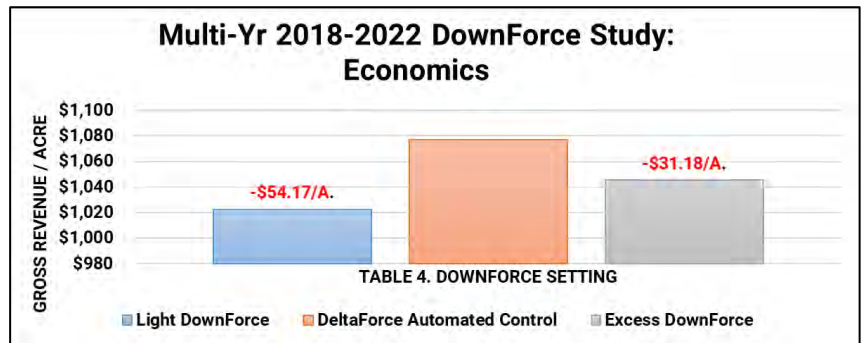

Planter “All Wrong Study”

Objective: This planter trial is designed to simulate yield and economic effects when a grower gets downforce, residue manager settings, and singulation incorrect on the planter, all at the same time. For this study we implemented light downforce, “goof” plates to achieve 95% singulation, and removed the use of residue managers.

Results: Table 1. reveals “All Wrong” planter settings caused yield losses of **-19.8 Bu/A**. Table 2. calculates economic losses of **-\$118.80/A**. when all three planter settings were incorrect. For more information on individual performance of these attributes, please see individual 2022 summary results for down force management, residue management trials, and singulation studies.

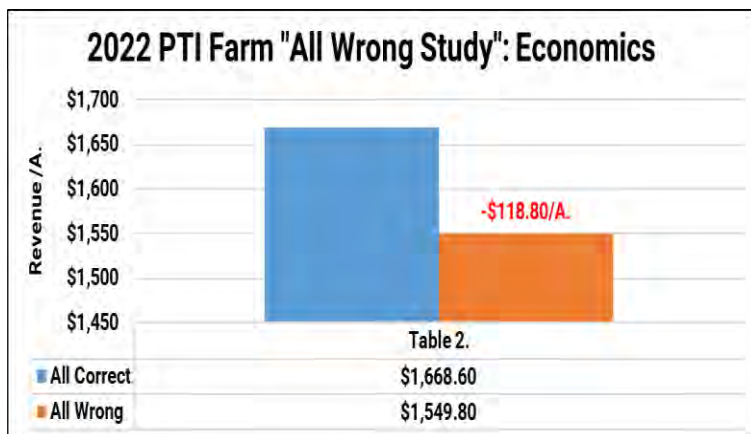
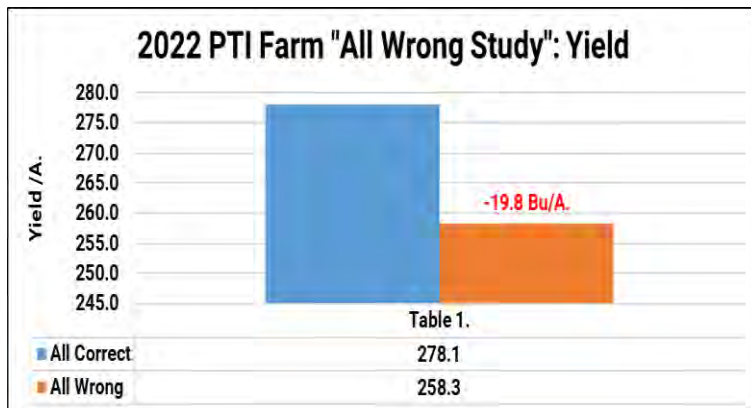

mSet® Multi-Genetic Planting Study

Objective: To analyze the yield and economic benefit of implementing mSet® single meter multi-genetic technology to place specific corn hybrids for individual spatial management zones.

mSet® is an upgradeable product to vSet® meters and vDrive® controller, which couples a seed selector added to the hopper to switch hybrids, and a seed pool level sensor in the meter (Figure 1.) The level sensor tells the seed selector when the meter needs more seed, and it drops a dose of seed into the meter. This continually happens until it is time to switch hybrids. At hybrid change, the level sensor will let the seed pool run low, then call for a dose of the other hybrid to enter the meter just in time for the change, leading to a short transition between hybrids. The seed pool is controlled by the mSet® selector (Figure 2.), providing the correct hybrid in the meter, and allowing the vSet® meter to accurately singulate those seeds. The ultimate result is the hybrid you select, planted in the area of the field you select, planted with highest accuracy of singulation. Additionally, for those who want to both; plant fast, and place hybrids by spatial zone variability, SpeedTube® system can be used in tandem with multi-genetic technology (Figure 3).

Figure 1. mSet® Box

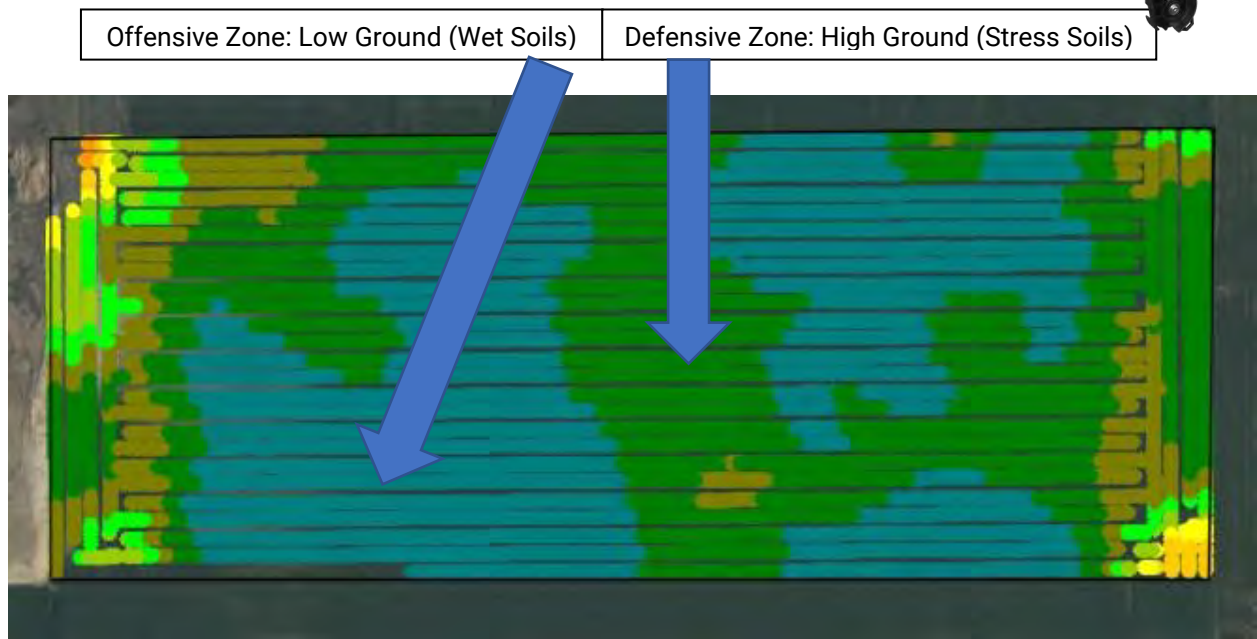

Figure 3. Speedtube®



Figure 2. mSet®

Figure 4. Offensive and Defensive Spatial Zones



Multi-Genetic Planting Study Continued

Results: Golden Harvest® 03R40 was used as our offensive corn hybrid in the lower elevation, higher OM, but potentially saturated soils. Conversely, Golden Harvest® 02K39 was used as the defensive hybrid planted into the higher ground, lower OM, and potentially droughty soils. Each genetic package was placed into the appropriate matching spatial management zone (Figure 4). Test blocks were planted to evaluate the yield performance when hybrids were placed correctly, as well as incorrectly.

Figure 5. illustrates the 2022 multi-genetic planting results. Correct placement in the defensive zone resulted in yield gains of +16.6 Bu/A. and corresponded to an economic advantage of +\$99.60/A.

Figure 5. also illustrates that the correct hybrid placement in the offensive zone resulted in yield gains of +12.0 Bu/A. and increased revenue of +\$72.00/A.

Figure 6. summarizes multi-genetic corn planting performance over the five-year time period of 2018-2022. During this timeframe, multi-genetic corn has offered increased yield gains of +11.3 Bu/A. with additional farm revenue of +\$47.84/A. in increased revenue. In each zone placement over the last 5 years, only once was the placement incorrect. This track record would suggest an 80% success rate for multi-genetic planting over 2018-2022 for each high/low yield zone.

Based on this data, if a grower invested \$1000/row on a 16-row planter for multi-hybrid technology, these types of yield and economic gains would result in return on investment at only 335 acres. These yield results confirm that a multi-genetic system can offer yield advantages and potentially large economic gains if used properly. For this system to work, growers and seedsperson need to work together to place the appropriate genetics on the correct acre and planted at suitable seeding rates.

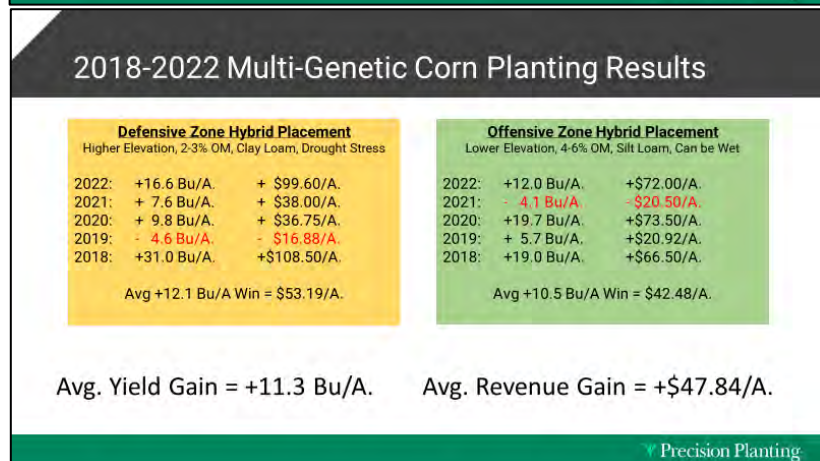
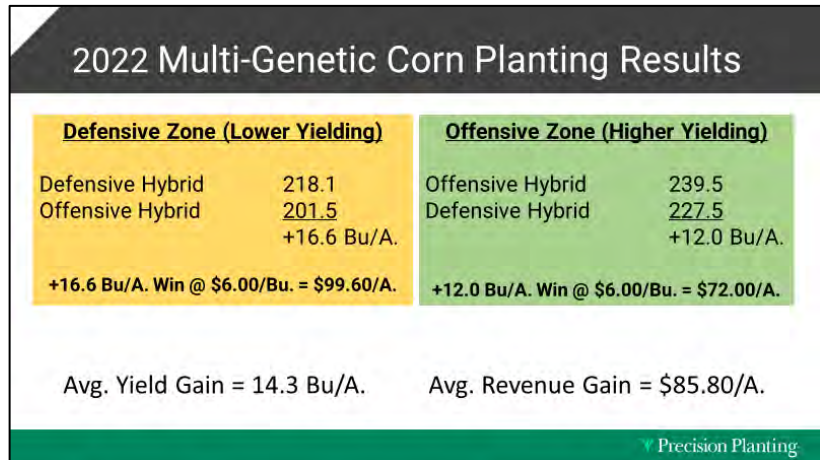

Rosens Stride Bio™ Hopper Box Treatment Study

Objective: To evaluate yield and net return of Stride Bio™, a talc/graphic/micronutrient planter box treatment.

Stride Bio is a 80/20 talc/graphic blend for planters that also contains Calcium, Magnesium, Sulfur, Iron, Manganese, and Zinc. It places essential nutrition, flow agents, and crop enhancement components directly on the seed to aid in singulation and improve seedling vigor and growth.

Results: Stride™ Bio hopper box treatments offered average yield gains of +2.8 Bu/A. with a positive net return on investment of +\$13.78/A.

As a first year product study, we look forward to testing this product again in 2023.



Guaranteed Analysis
0-0-0

Calcium (Ca).....	1.0%
Magnesium (Mg).....	0.5%
Sulfur (S).....	4.0%
4.0% Combined Sulfur	
Iron (Fe).....	0.1%
0.0% Water Soluble Iron	
Manganese (Mn).....	4.0%
4.0% Water Soluble Manganese	
Zinc (Zn).....	10.0%
4.0% Water Soluble Zinc	
Derived from: Dolomitic Limestone, Iron Oxide, Manganese Sulfate, Zinc Sulfate, Zinc Oxide.	

Also contains non-plant food ingredients: Talc & Graphite in an 80/20 ratio.

GENERAL INFORMATION

Stride Bio places essential nutrition, flow agents, and crop enhancement components directly on the seed to aid in singulation and improve seedling vigor and growth. Stride Bio is compatible with fungicide, insecticide seed treatments and inoculants, but does not replace those products. Stride Bio replaces the need for adding talc or graphite.

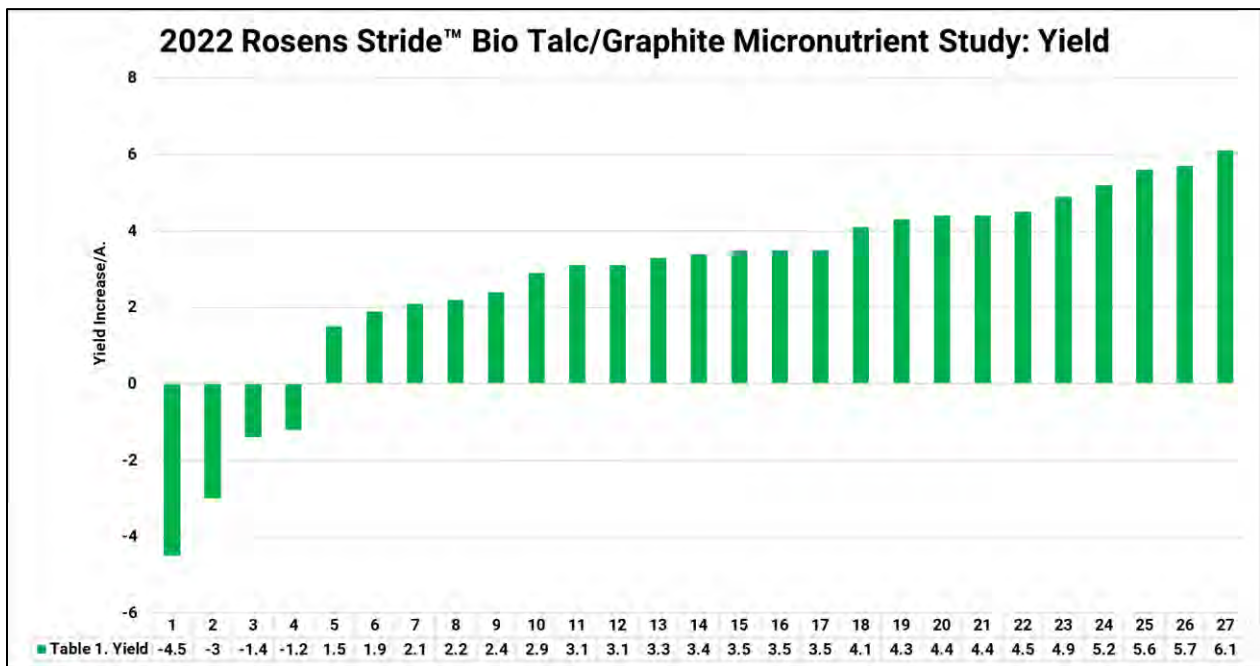

Rootella® F Hopper Box Corn Inoculant Study

Objective: To evaluate yield and net return of Rootella® F planter box treatment.

Rootella® F concentrated fine powder mycorrhizal inoculant effectively inoculates plants with vigorous endomycorrhizal fungi. The mycorrhizal inoculation improves plant nutrient uptake and has been proven to improve crop yield; reduce fertilizer, compost, and irrigation requirements; and increase plant durability under stress. Rootella® F mycorrhizal inoculants are ideal for manual mixing with seeds. This product formulation clings to seeds and lends itself well to the planter box applications.



Results: Hopper box treatments of Rootella® resulted in yield gains of +1.8 Bu/A. At a \$6 corn commodity price and a product cost of \$6.50/A., Rootella® offered economic gains of \$4.30/A.

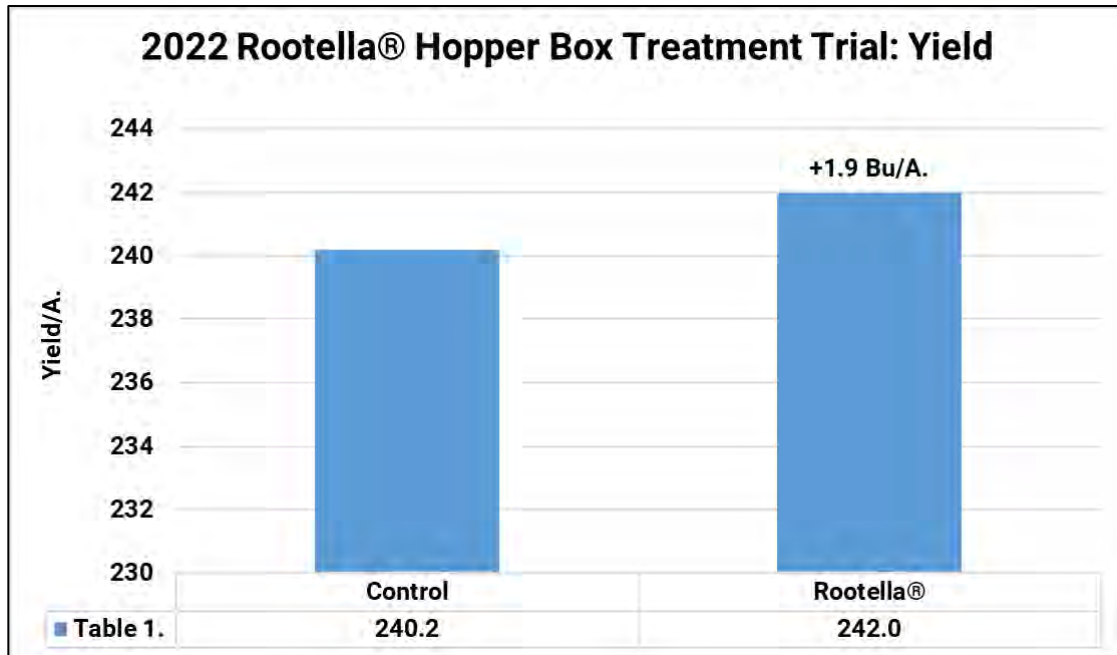

Planting Date: May 15th Hybrid: DK 56-65 Population: 36K Row Width: 30" Rotation: CAB Corn Price: \$6.00 Rootella®: \$6.50/A.

TerraMax Hopper Box Corn Inoculant Study

Objective: To evaluate the use of TMicroAZ-ST Dry™, a seed treatment inoculant that aids with bacterial growth and survival. MicroAZ-ST Dry™ is a Azospirillum based product that help microbes fix atmospheric nitrogen to a usable form and gather more nitrogen from the soil. Once the bacteria attach to the roots it helps to stimulate root development to improve nutrient uptake.

Results: MicroAZ-ST Dry™ treatments resulted in yield gains of +1.6 Bu/A. At a \$6 corn commodity price and a product cost of \$5.91/A., MicroAZ-ST Dry™ offered economic gains of \$3.69/A.

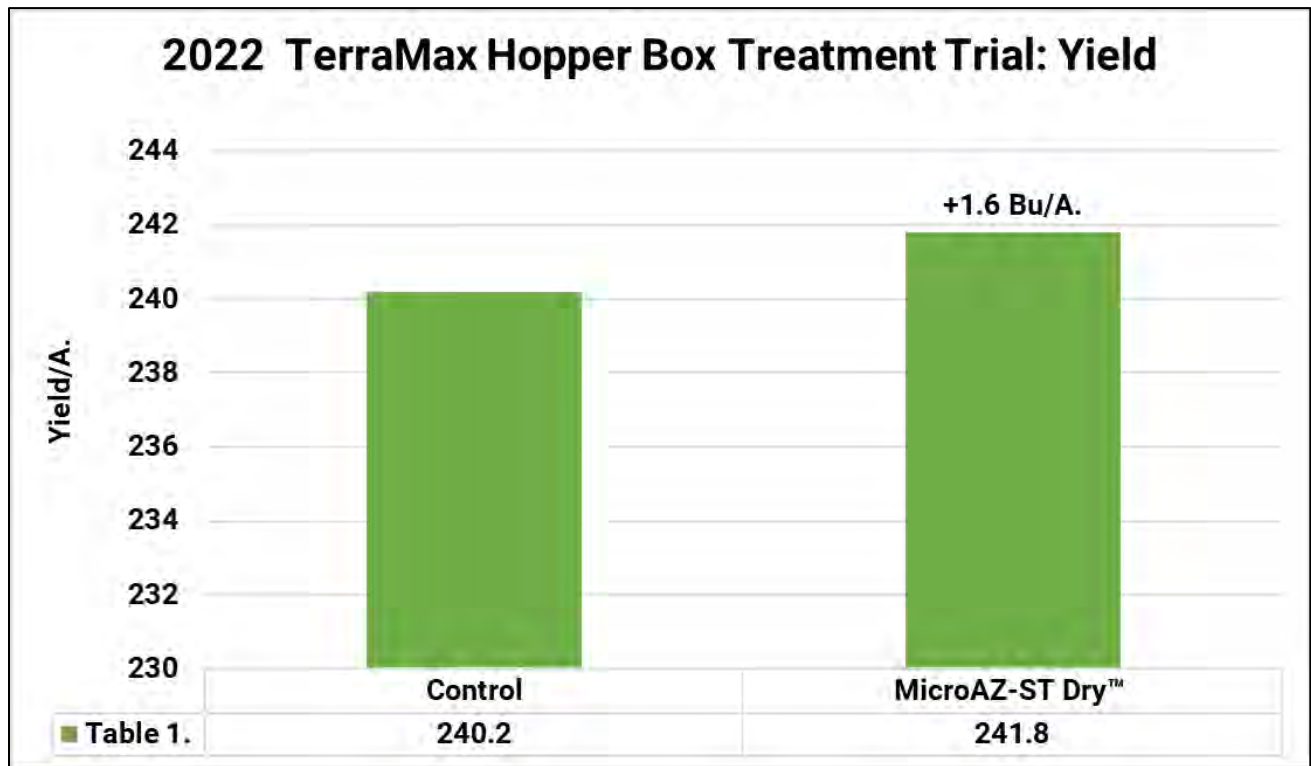

Terrasym® 450 + Dust™ Hopper Box Corn Inoculant Study

Objective: To evaluate the use of Terrasym 450, a unique strain of beneficial microbes called pink pigmented facultative methylotrophs (PPFMs), specially selected for use in corn.

NewLeaf Symbiotics® and Low Mu Tech™ have combined proprietary Terrasym® microbial technology with a micro-plastic free, patented DUST™ seed flow lubricant. Terrasym® 450 + DUST™ for corn is designed to improve seed lubrication and seed flow during planting and deliver improved nutrient uptake leading to robust early season root development, enhanced tolerance of abiotic stress throughout the growing season, and higher yields at harvest.

Results: Hopper box treatments of Terrasym® 450 + Dust™ resulted in yield gains of +0.7 Bu/A. over standard 80/20 talc graphite applications. At a \$6 corn commodity price and a product cost of \$4.35/A., economics netted +0.00/A. and broke-even.

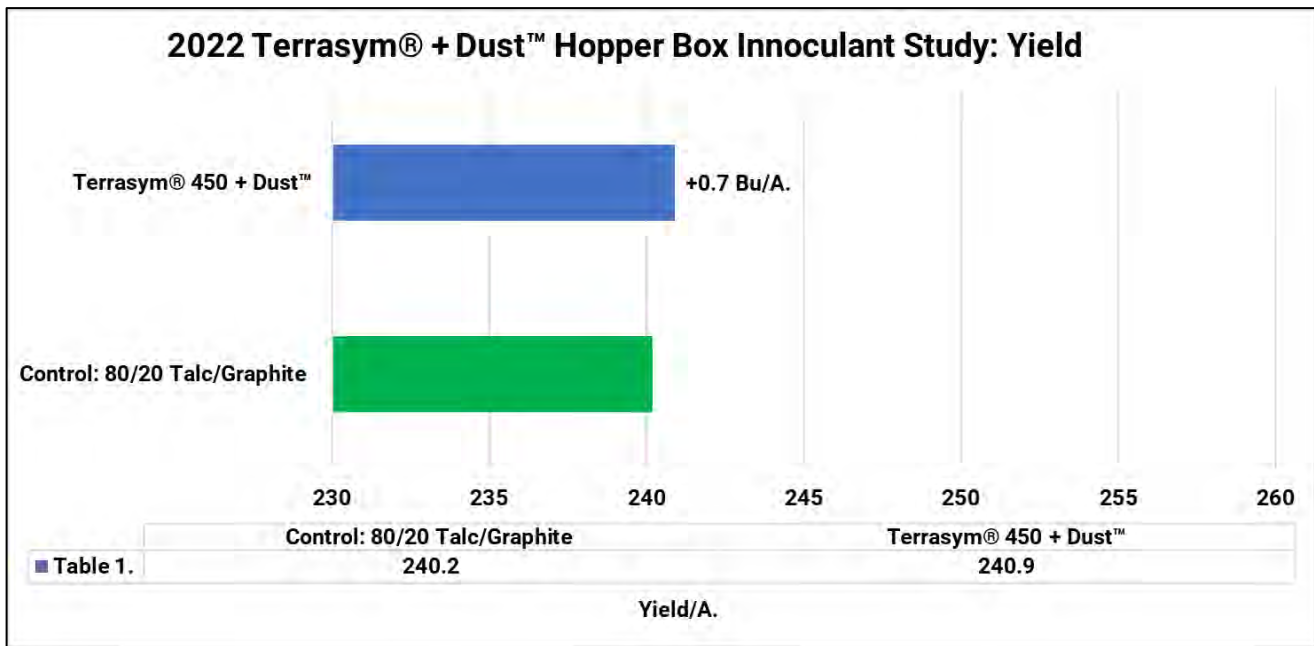

Banding Dry Fertilizer Study

Objective: To evaluate yield and economics of traditional broadcast applications of dry fertilizer compared to 8" deep high concentrated strip-till banding.

Based upon soil test results and yield goals of 250 Bu/A. corn in a corn/soybean non-irrigated rotation, 130# 18-46-0 and 65# 0-0-60 was applied in a traditional broadcast surface application made with a traditional spinner truck (Figure 1). Using the same 100% fertilizer rates, a strip-till bar was used to place fertilizer in high concentrated strips 8" deep on 30" corn rows (Figure 2). Corn was then planted directly into the strips above the 8" fertilizer placement. A KUHN® Krause® 1200 Gladiator® pulling a Montag® Equipment 2208 Gen 2 fertilizer cart was used to implement this testing program for 2022.

Results Table 1. illustrates strip-till fertilizer resulted in +4.2 Bu/A. yield gains over traditional broadcast applications. Corn yield from broadcast fertilizer averaged 263.5 Bu/A., while strip-till 267.7 Bu/A.

Figure 1. Broadcast Dry Fertilizer



Figure 2. Strip-Till Banded Fertilizer

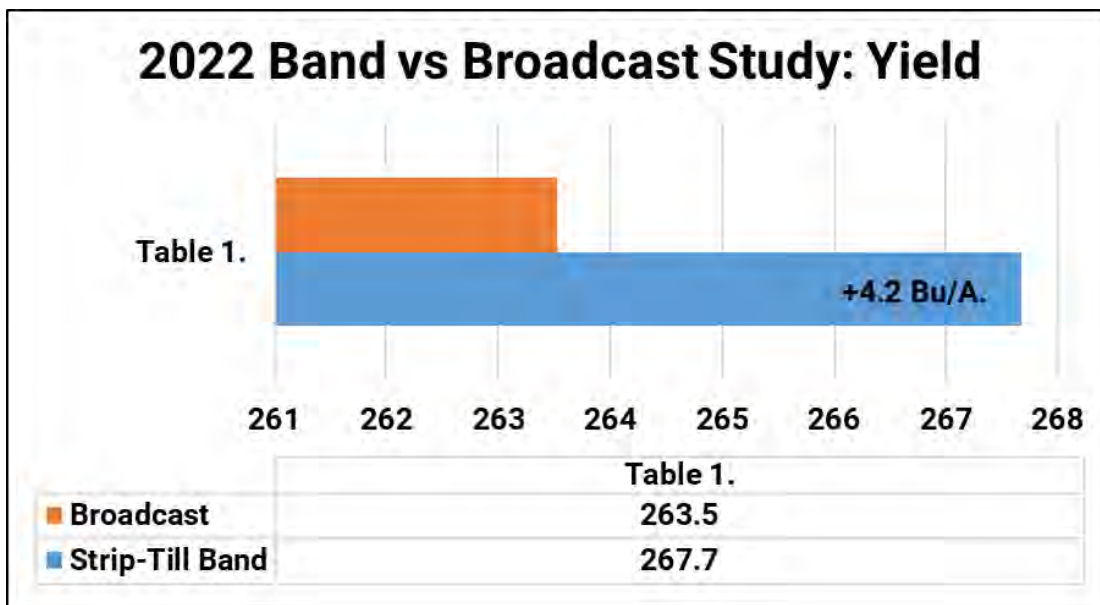

Broadcast vs Banding Dry Fertilizer Study Continued

Using University of Illinois Machinery Cost Estimates in Table 2., strip-till resulted in additional costs of +\$9.60/A. in comparison to a conventional tillage program. Using this cost scenario, Table 2. illustrates the economic impact from our 2022 study. Strip-till, with its tillage and fertility system, posted positive economic gains of +\$15.60/A. over a conventional tillage system.

Table 2. University of IL Machinery Cost Estimates

Tillage Practice	Category	Cost
Conventional	Soil Finisher	\$ 11.10
	Plant	\$ 17.20
	Fertilizer Spread	\$ 3.00
	Total:	\$ 31.30
Strip Till	Strip	\$ 17.30
	Plant	\$ 17.20
	Burndown	\$ 6.40
	Total:	\$ 40.90

Table 3. illustrates multi-year data from the PTI Farm over the years 2020, 2021 and 2022. Over this timeframe, banding dry fertilizer has resulted in average yield gains of +9.9 Bu/A. with a return on investment of +\$32.77/A.

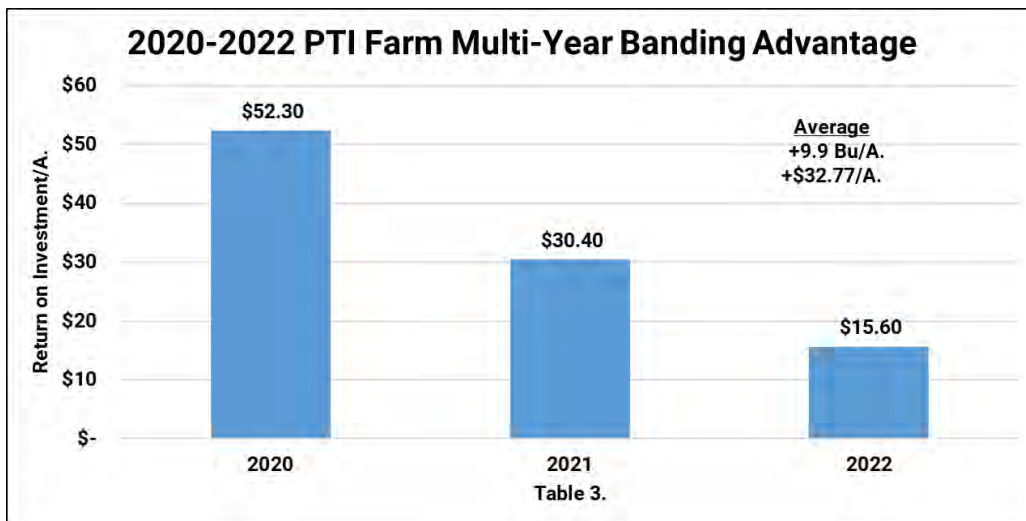

Planting Date: May 11th

Hybrid: DKC 59-82

Population: 36K

Row Width: 30"

Rotation: CAB

Corn Price: \$6.00

Broadcast vs Banding Rate Efficiency Study

Objective: To evaluate yield and economics of traditional broadcast applications of dry fertilizer compared to concentrated strip-till bands applied 8" in depth under the corn row.

Based upon soil test results and yield goals of 250 Bu/A. corn in a corn/soybean rotation, 130# 18-46-0 and 65# 0-0-60 was applied as a recommended fertility application from a Fall 2021 soil test.

To study placement efficiency, dry fertilizer was applied in a traditional broadcast surface application as a spinner truck (Figure 1). Using the same fertilizer rates, a strip-till bar was used to place fertilizer in high concentrated strips 8" deep on 30" corn rows (Figure 2). Corn was then planted directly into the strips above the 8" fertilizer placement. Corn was also planted in a strip-till situation with the broadcast fertilizer, however as surface applied on top of the fall strips. A KUHN® Krause® 1200 Gladiator® pulling a Montag® Equipment 2208 Gen 2 fertilizer cart was used to implement this testing program for 2022.

To then study rate efficiency, fertilizer was applied at the following rate structure in both strip-till bands and broadcast applications:

- ✓ 100% Fertilizer Rate
- ✓ 75% Fertilizer Rate
- ✓ 50% Fertilizer Rate
- ✓ 25% Fertilizer Rate
- ✓ 0# Rate

Figure 1. Broadcast Dry Fertilizer



Figure 2. Strip-Till Banded Fertilizer with Montag® cart



Figure 3. KUHN® Krause strip-till unit



Broadcast vs Banding Rate Efficiency Study Continued

Results: Table 1. illustrates the yield of all rates in band and broadcast applications. Highest yield came from 100% and 75% bands at 267.7 to 263.8 Bu/A. Overall, high concentrated bands of fertilizer surpassed broadcast spreading yields at every individual rate percentage by an average of 4.0 Bu/A. Conversely, 0# fertilizer resulted in only 9 Bu/A. yield losses compared to 100% fertilizer rates in a band.

Table 2. summarizes economic optimum rate and placement. 0# of fertilizer proved economic optimum fertilizer rate. With 0# fertilizer rates yielding within 9 Bu/A. of 100% rates, compounded with historically high DAP and Potash prices, a 9 Bu/A. fertilizer advantage will not pay for itself. Each time fertilizer was reduced, it created a positive return on investment compared to 100% broadcasted rates. 75% bands resulted in gains of +\$8.73/A., 50% bands +\$18.07/A. and 25% at +\$30.40/A.

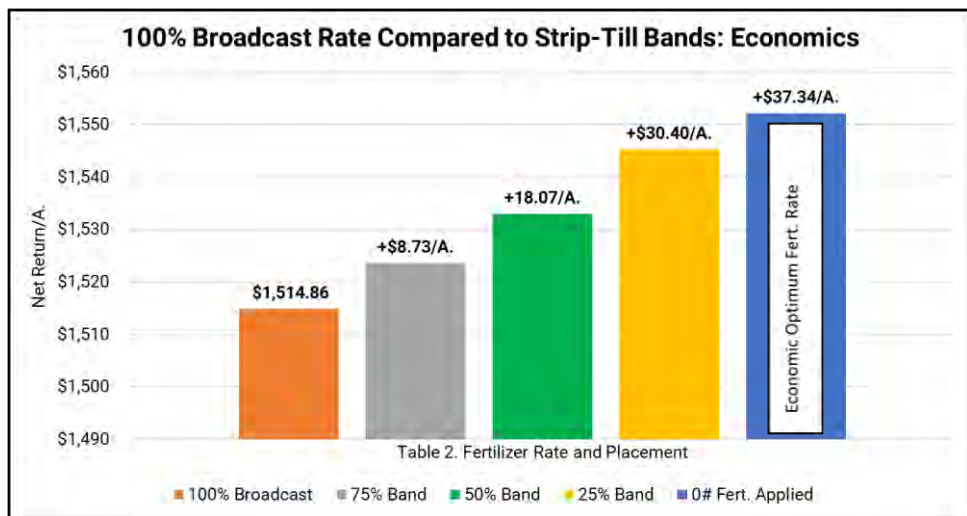
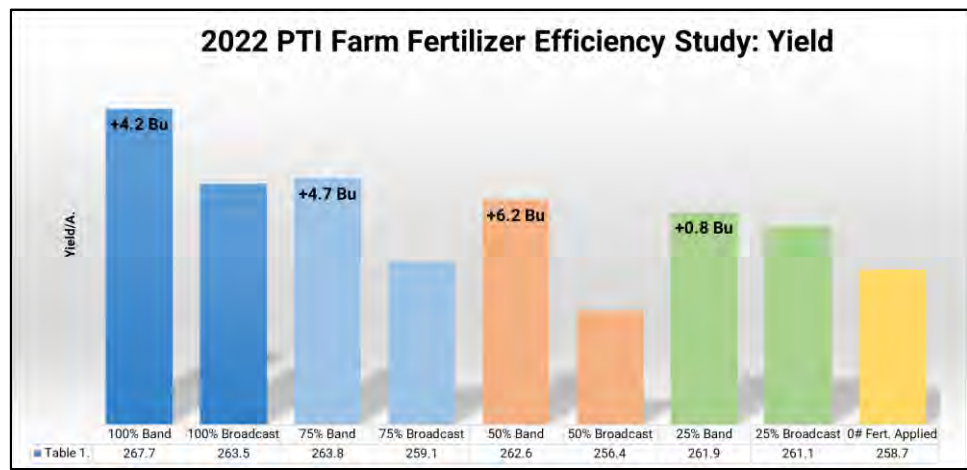

Broadcast vs Banding Rate Efficiency Study Continued

Table 3. illustrates a scenario using 2022 corn yield by fertilizer rate, however, assumes a 50% cost reduction of DAP and Potash for the study. Since farmers are battling historical high prices of fertilizer today, we thought it would be interesting to see if fertilizer response would pay for itself even in a 50% lower cost scenario? However, even with 50% cost, reduced rates of fertilizer still offered positive return on investment. In fact, 0# of fertilizer resulted in economic gains of \$4.27/A. All other reduced banded rates offered gains as well, ranging from +\$0.47/A. to +\$5.60/A. What does this mean? Fertilizer did not pay for itself in 2022.

This is the second year in a row where reduced rates of fertilizer proved higher return on investment than what was determined by soil testing and standard recommendations. Table 4. illustrates 2021 economics of 100% broadcast fertilizer, compared to 75%, 50% 25% and 0# banded fertilizer rates. For the 2021 growing season, a 50% reduction of fertilizer achieved economic optimum rate. This 50% reduction is interesting, as we thought it might indicate banding could offer a 50% efficiency factor compared to 100% broadcast rates. However, in year two of this ten-year study, this theory may not be accurate, as 0# rates of fertilizer actually provided a higher return on investment compared to applied fertilizer rates in 2022.

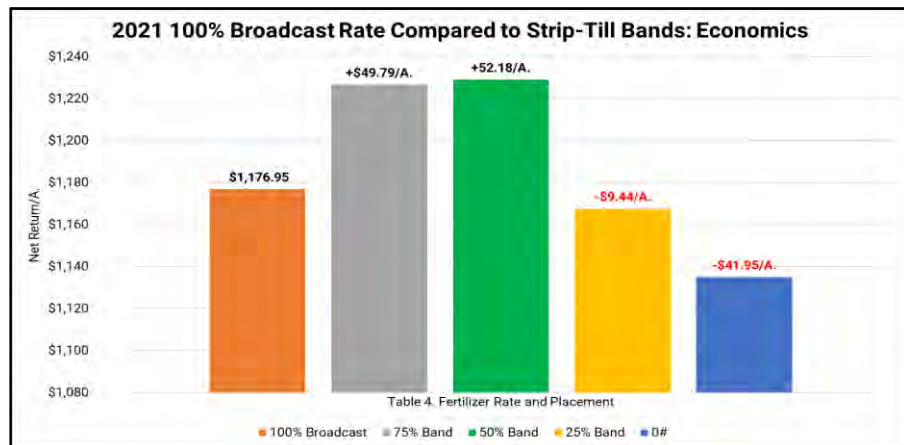
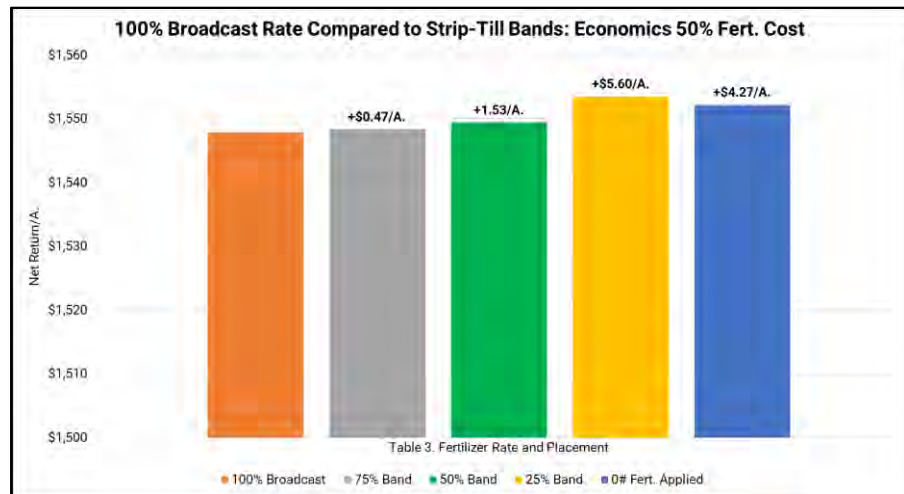

Mosaic® Sulfur/Boron Dry Fertilizer Study

Objective: To evaluate yield and net return of Mosaic® fertilizer products MicroEssentials® SZ®, and Aspire® to offer sulfur and boron in addition to traditional dry phosphorous and potassium fertilizer.

MicroEssentials® SZ® is a 12-40-0-10S-1Zn and combines nitrogen, phosphorus, sulfur, and zinc into one nutritionally balanced granule, creating a single source for balanced crop nutrition. The unique chemistry and precise nutrient ratio of MicroEssentials® features; uniform nutrient distribution, increased nutrient uptake, and season long sulfur availability.

Formulated using Nutriform® technology, Aspire® is a 0-0-58 that provides two forms of boron (Sodium Borate 50% and Calcium Borate 50%) with potassium into a single granule for uniform nutrient distribution, season-long boron availability and flexible spring or fall application.

In this study, both Mosaic products are equivalently compared to traditional applications of 230#/A. of 18-46-0 DAP and 130#/A. of 0-0-60 potash as a control.



12	40	0	10	1
N	P ₂ O ₅	K ₂ O	S	Zn



0	0	58	0.5
N	P ₂ O ₅	K ₂ O	B



Mosaic® Sulfur/Boron Dry Fertilizer Study

Boron (B) is a micronutrient critical to the growth and health of all crops. It is a component of plant cell walls and reproductive structures. Boron, a water-soluble micronutrient, is especially prone to leaching. Since boron is a neutrally charged ion, it floats in ecosystems until it finds a substance to which it can bond to. During periods of heavy rain, boron is flushed out of the soil quickly. Boron serves two primary roles; one is supporting plant cell division, and the second is during the silking stage of development, in which boron helps transfer water and nutrients from the roots up through the plant. B is required in small amounts, in fact a 200 Bu/A. crop only uptakes 0.2lbs of B.

Sulfur (S) is an essential nutrient for corn growth and is a critical nutrient to make required proteins. One bushel of corn typically requires 0.1 to 0.12lbs/Bu. S uptake occurs over the entire growing season, with relatively constant uptake from the 14-leaf stage to maturity. Unlike nitrogen, only 40% to 50% of S is taken up by flowering. S is also very mobile in most soils, like nitrate, because it has a double negative charge and is repelled by the negative charge of the soil, unlike nutrients like potassium, calcium, or magnesium

Results: Mosaic® Micro-Essentials® SZ® and ASPIRE® treatments offered yield advantages of +6.6 Bu/A. in replicated testing at the PTI Farm in 2022. These yield advantages equated to positive net returns of +\$11.50/A. after cost of product. For growers who do not have the ability to incorporate Sulfur or Boron as part of a liquid program, these products could offer growers an option to do so.

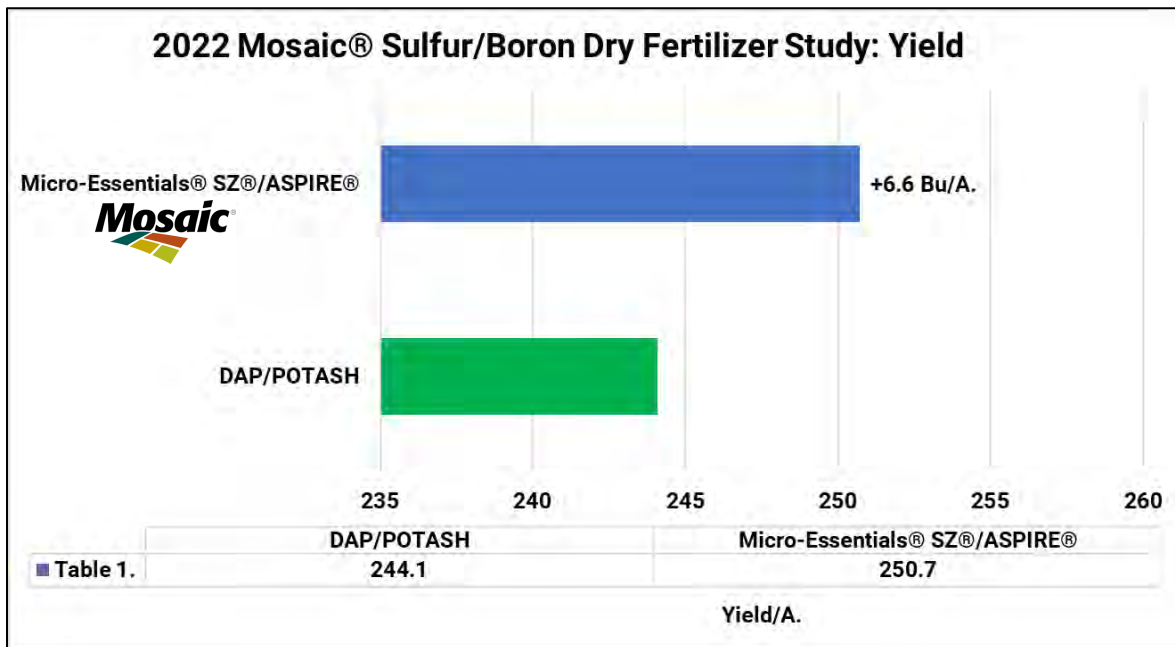

Calcium Products™ S04® Study

Objective: This trial evaluates the yield response and economics of pelletized calcium sulfate (S04) applied fall broadcast and as banded spring strip-till. Sulfur is an essential component of plant growth with key processes relying on chlorophyll formation and protein production. Sulfur is considered the fourth major nutrient behind N, P, and K.



S04® from Calcium Products is a 21% Calcium (non-pH neutralizing) and 17% Sulfur dry pelletized fertilizer, mined, and manufactured in NW Iowa. It is finely ground and pelletized to achieve a balance of solubility and pellet strength.

Historically, much of the sulfur need was satisfied with atmospheric deposition as result of coal burning industries. However, amendments to the Clean Air Act in 1990 targeted sulfur emissions, resulting in less than ½ of the amount of sulfur today compared to 30 years ago.

Results: Banded strip-till applications of S04 resulted in yield gains of +3.4 Bu/A. over broadcast applications. Banded S04 achieved net returns of +\$19.50/A., while broadcast resulted in losses of **-\$0.90/A.**

Multi-year data from 2019, 2020, 2021 and 2022 has proven +7.9 Bu/A. yield gains with positive return on investment of +\$16.43/A. on all strip-till banded applications of S04.

Releases Sulfur to Match Plant Needs

S04 supplies a balanced initial sulfur release and a steady supply throughout the growing season. AMS releases sulfur too quickly, and elemental sulfur releases sulfur too slowly, neither meeting the crop's complete needs.

Spreads Easily

S04's consistent pellet size allows it to be blended and applied with other dry fertilizers, which means it doesn't require a separate application. It can be applied pre-plant in the spring, in-season via top dress or post-harvest in the fall.

Will Not Acidify Soil

S04 is pH neutral, meaning it will not acidify the soil like other sulfur sources. Proper soil pH maximizes a plant's utilization of nutrients promoting good plant health and optimizing yield.

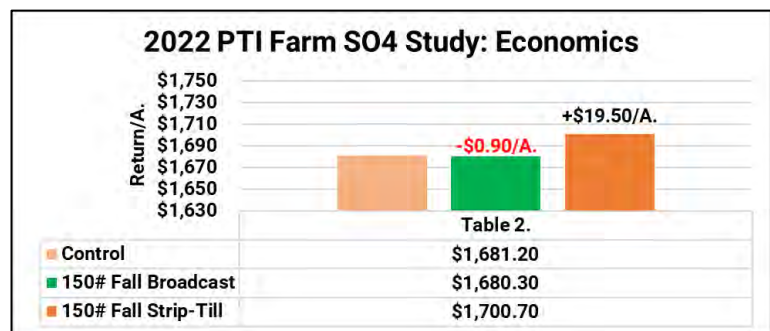
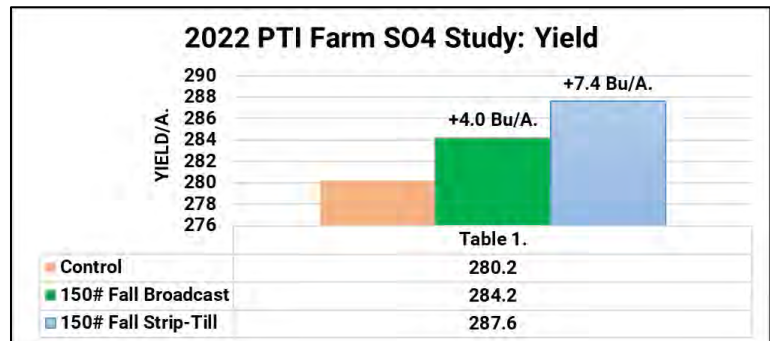

Planter Applied Micro-Nutrient Study

Objective: To evaluate yield and net return of dry micronutrient fertilizer products at planting. The goal of this study is to use low-rate micronutrient fertilizer products applied at-plant, using a Gandy® Dry fertilizer box on the back of a planter row unit (Figure 1). All fertilizer is banded, and surface applied with some incorporation of planter closing system on 30" planted rows.



Figure 1. Gandy® Fertilizer Box on PTI Plot Planter

Six fertilizer products were selected and evaluated in this study, including the following:

**WINFIELD®
UNITED**

Winfield® United Corn Mix LS: A granular 7% Sulfur, 1% Boron, 1% Copper, 3% Manganese and 8% Zinc micronutrient fertilizer containing lignosulfonate compounds derived from plant material to help correct nutrient deficiencies in a range of crops, improving mobilization and utilization. Micronutrients complexed with lignosulfonate work to reduce soil tie-up, and water-soluble formulations help improve water transferabsorption and plant uptake of nutrients.

Midwestern
BIOVAG®

Midwestern BioAg® MicroPack 5-5-5™: A balanced, homogenized combination of N-P-K, Calcium, Magnesium, Sulfur, and micronutrients. It is a granular fertilizer that provides balanced micronutrient nutrition for all crops, helping to maximize yield potential and plant and soil health.

Planter Applied Micro-Nutrient Study Continued



Winfield® United Zinc 10% LS: A lignosulfonate granular micronutrient containing Zinc and Sulfur to address nutrient deficiencies in corn, wheat and other crops. Zinc 10% LS improves plant mobilization and utilization of nutrients.



MicroSync™ Complete®: A 2-0-0- fertilizer containing 5% Calcium, 10% Sulfur, 1.25% Boron, 1.25% Copper, 3.5% Iron, 5% Manganese, and 5% Zinc. MicroSync™ Complete® is formulated with Verdesian Polymer Technology to help synergize and increase the availability of both secondary and micronutrients for plant uptake. Also includes Nutripaction®, a process that creates a unique combination of micronutrition that offers improved nutrient availability.



Soileos®: Repurposed cellulose derived from agricultural residues such as pea hulls and lentil husks that promote nutrient cycling in the soil. The carbon in Soileos® is fuel for soils microbiome, and as the cellulose is broken down, microbes release or ingest nutrients. Contains 8.5% Potassium, 4.7% Sulfur, 5% Zinc, 2.5% Manganese, 1% and Iron.



MicroMark® DG Humic: A granular micronutrient product featuring The Andersons® Dispersing Granule (DG) Technology. With DG Technology, particles are efficiently broken down through hydrolysis, increasing the efficacy of nutrients. MicroMark® DG Humic contains a unique blend of 36% calcium sulfate dihydrate 9% calcium, 11% sulfur, 4% manganese, and 5% zinc. MicroMark® DG Humic also includes humic acid which is a natural chelator of micronutrients and also has been shown to improve soil health

Planter Applied Micro-Nutrient Study

Results: All six products resulted in positive yield gains at the 5#/A. rate, however The Andersons® MicroMark® DG Humic offered highest yield gains of +7.2 Bu/A. with positive net returns of +\$37.70/A. Verdesian MicroSync™ Complete® also performed well at +3.5 Bu/A. with net returns of +\$12.25/A.

As rates climbed to 10#/A., all products resulted in positive yield gain and net return. The Andersons® MicroMark® DG Humic again offered highest yield gains of +17.4 Bu/A. with positive net returns of +\$93.40/A. Verdesian MicroSync™ Complete® also performed well again at +9.8 Bu/A. with net returns of +\$41.30/A. All other products resulted in yield gains of +3.2 to +9.4 Bu/A. with net returns of +\$10.70 to +\$32.90/A.

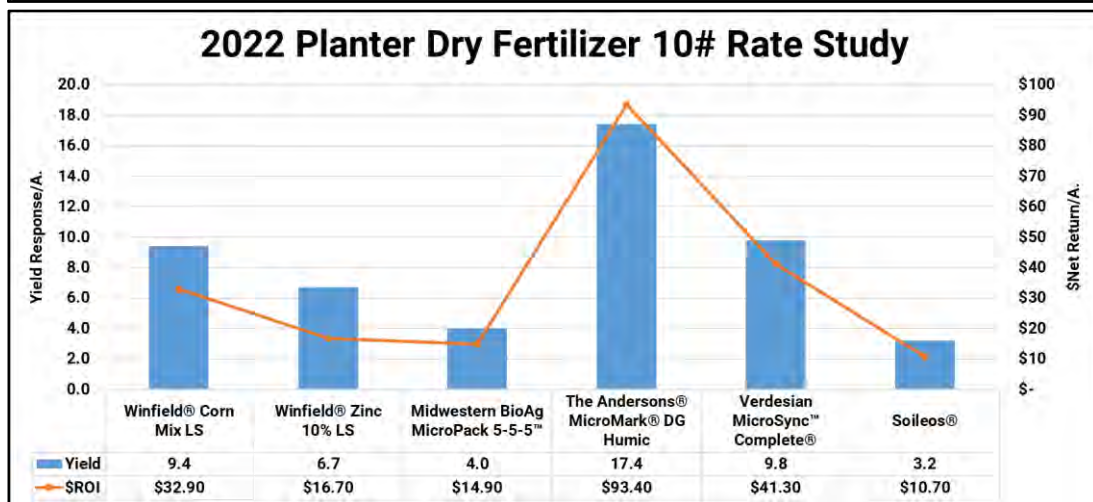
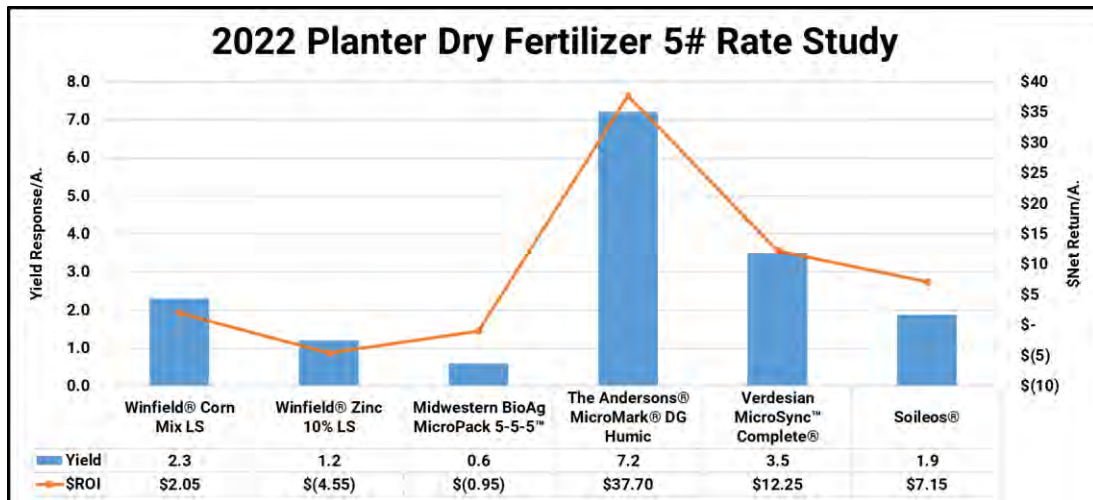

Planting Date: 4/27 Hybrid: Golden Harvest® 11V76 Population: 36K Row Width: 30" Rotation: CAB, Strip-Till Corn Price: \$6.00

Winfield Zinc 10% LS: #2.35/#, Corn Mix LS: \$2.35/# MicroMark® DG: \$1.10/# MicroPack 5-5-5™: \$.91/# MicroSync™ Complete®: \$1.75/# Soileos®: \$0.85/A#

High Management Corn NETAFIM® Irrigation Study

Objective: This study evaluates NETAFIM® drip tape irrigation designed by NutraDrip Irrigation Systems, and its' ability to feed corn with water and nutrients for high yield potential. This method of irrigating a crop uses NETAFIM® drip tape with small pressure regulated emitters evenly spaced at 24" apart. Water is accessed from a water recycling management program installed at the PTI Farm.

Results: In 2022, NETAFIM® drip tape irrigation resulted in increased average corn yields of 38.1 Bu/A., over the non-irrigated control. 6.25" of rain was applied through drip irrigation throughout the growing season from June - September. Fertigation was also implemented to apply N, B, Cu, S, P, and K as needed.

Multi-Year data over 2019-2022 has proven to increase corn yield by an average of +64.8 Bu/A., while increasing additional gross income by an average of +\$286.39/A.

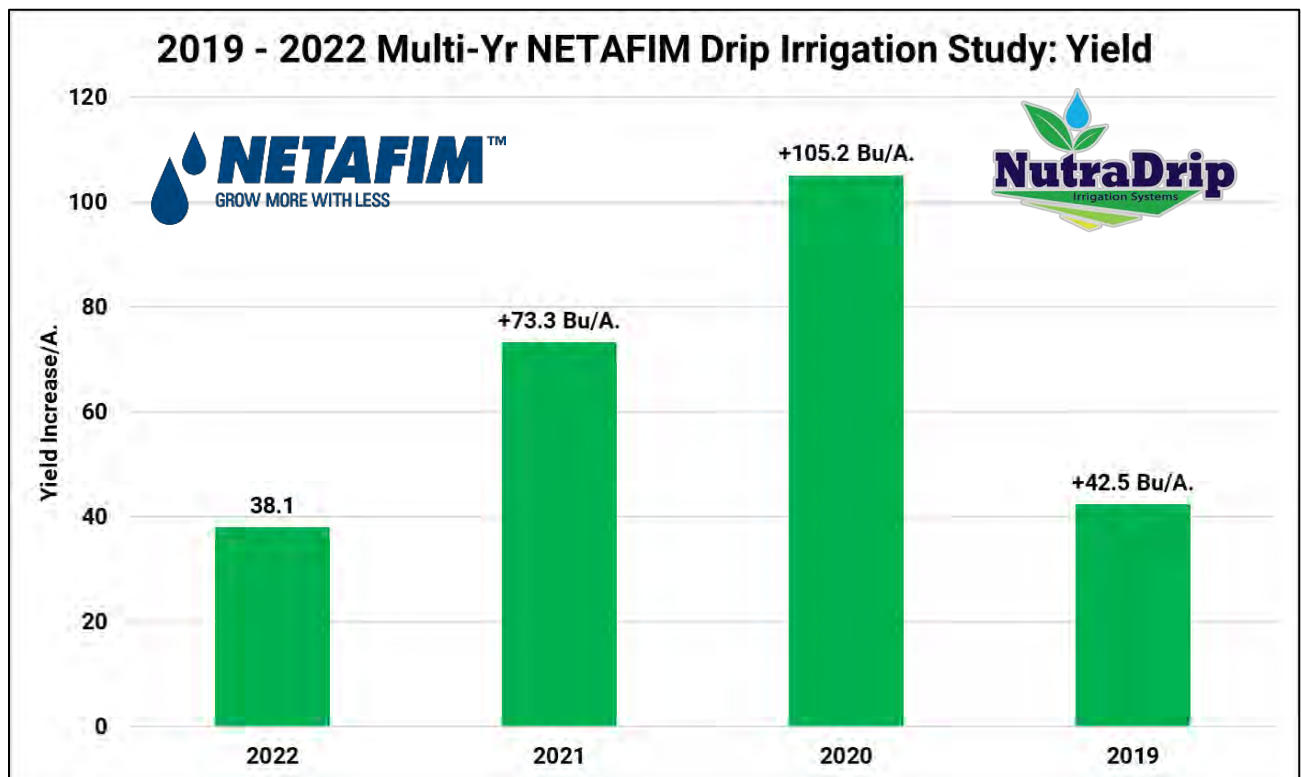

NETAFIM® Sub-Surface vs Surface-Irrigation Study

Objective: This study evaluates NETAFIM® drip tape irrigation and its' ability to feed corn with water and nutrients for high yield potential in a surface and sub-surface installation.

This method of irrigating a crop uses NETAFIM® drip tape with small pressure regulated emitters evenly spaced at 24" apart. Water is accessed from a water recycling management program installed at the PTI Farm.

Surface irrigation is placed on top of the soil surface on 60" spacing down the middle of the 30" row (Figure 1).

Sub-surface irrigation is buried 14" in depth on 40" centers (Figure 2). Sub-surface irrigation was installed in the fall of 2021.

Figure 1. NETAFIM® Surface Irrigation



Figure 2. NETAFIM Sub-Surface Irrigation



NETAFIM® Sub-Surface vs Surface-Irrigation Study

Results: NETAFIM® sub-surface drip tape irrigation resulted in increased average corn yields of +6.6 Bu/A., over surface applied drip tape. Sub-surface irrigation tape was installed in the fall of 2021 and just like drainage tile, we had a suspicion that it may take some time for sub-surface drip irrigation to settle into place correctly, repair soil density of installation, and get proper water permeability throughout the soil profile quickly. These positive yield gains of +6.6 Bu/A. are encouraging to see the first year of this study and we think these numbers could go much higher in future years as the aspects mentioned above improve on an annual basis.

Surface drip irrigation has its advantages and disadvantages. It can be an effective, faster way to get water to a crop, however it can suffer moisture losses being exposed to sunlight, temperature, and wind on the soil surface. Keeping the soil surface moist can also lead to a higher threat of disease. Labor is also a concern, as the tape needs to be manually laid and picked up annually.

6.25" of rain was applied through drip irrigation throughout the growing season from June - September. Fertigation was also implemented thru both systems to apply N, B, Cu, S, P, and K as needed.

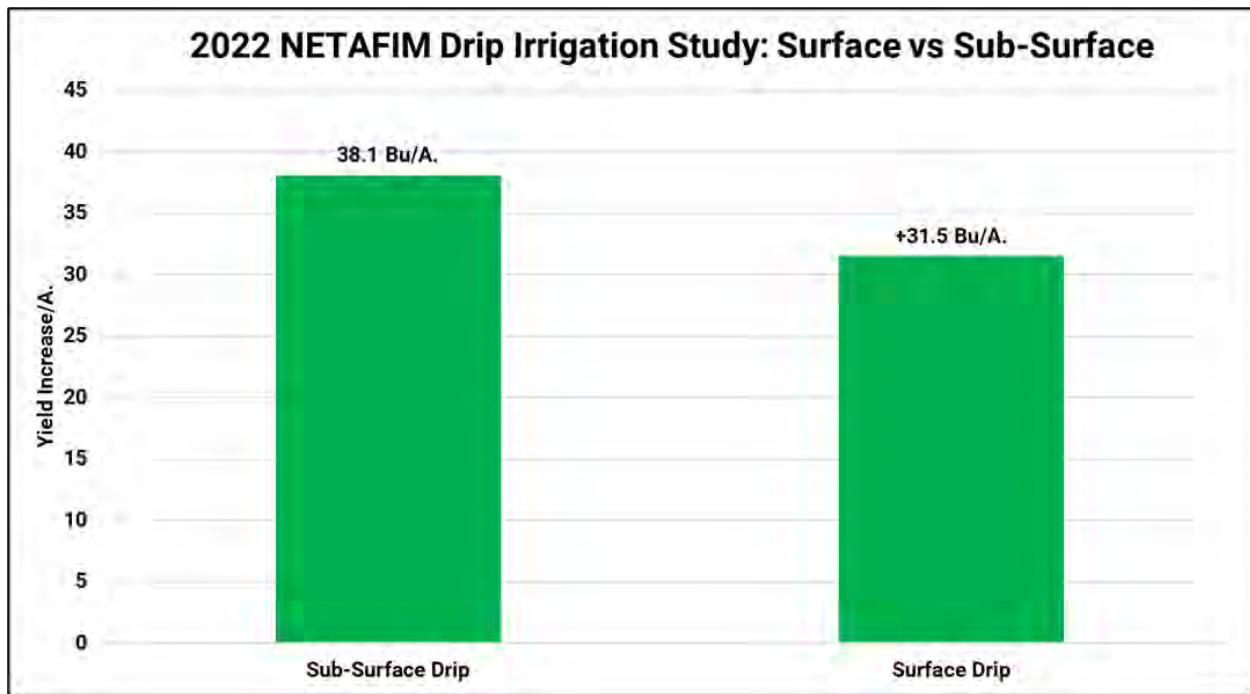

Tile Drainage and Sub-Irrigation Study

Objective: To evaluate the performance of using field tile as a form of irrigation. Normally, field tile is used to only drain saturated soils (Figure 1.) However, in this study we installed 15' and 30' 3" plastic field tile to compare its ability to not only drain water, but to also back-feed irrigation water back through the field tile to offer irrigation to a growing crop.

Figure 2. shows the layout of our pattern tiled field installed in the early spring of 2021. Both 15' and 30' pattern tile widths were used to understand the difference in the soil's capillary action or uptake of water. This study is one of many at the PTI Farm designed as long-term 10+ year studies to study consistency and longevity of the system.

Figure 1. Tile Installation



Figure 2. 15' and 30' Pattern Tile Installation



Tile Drainage and Sub-Irrigation Study

Results: The first objective of this study was to evaluate the differences between tile spacing. In 2022, 15' pattern tile offered yield advantages of +18.9 Bu/A, which equates to additional gross farm revenue of +\$113.40.

30' pattern tile offered yield advantages of +14.2 Bu/A. and gross revenue of +\$85.20/A. These numbers would indicate that it fell behind 15' pattern tile by only **-4.7 Bu/A.** with corresponding gross revenue loss of only **-\$28.20/A.** We believe this small discrepancy is due to the lack of heavy rainfall events throughout the growing season. In fact, 6.25" of irrigation water was needed throughout the summer months to offset the lack of rainfall.

With the 2022 yield and revenue documented, both 15' and 30' tile pattern systems would pay for themselves after 10 crop seasons (\$850/A. 30' Tile, \$1160/A. 15' Tile). This is interesting, as the overall tile response of +14 to +19 Bu/A. are the lowest responses we have seen since the tile was installed at the PTI Farm. In a dry year, we are still looking at a 10 year payback.

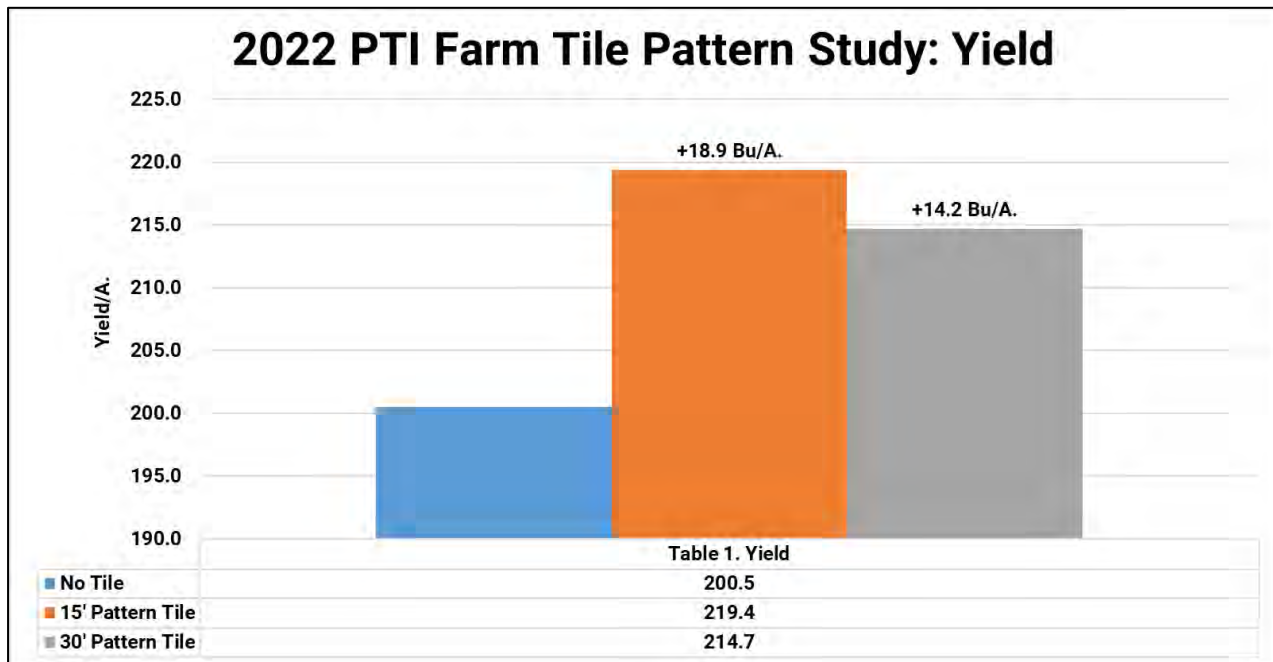

Tile Drainage and Sub-Irrigation Study

Secondly, the other objective of this study, is using the drainage tile as option to sub-irrigate. Figure 3. is a photo of a gate system that gives the ability to control the water table. Gates can be added or removed to allow water to “back-feed” or “fill up” the tile, which in turn draws water up into the soil profile. Water is sourced and pumped out of the PTI Farm’s water recycling reservoir to back-feed the water through the tile system in the field.

Table 2. illustrates back-feeding water gained +6.8 Bu/A. in 15’ tile pattern tile and only +3.5 Bu/A. in 15’ tile patterns. Though seemingly small yield gains, what was a 10-yr payback period mentioned above from just drainage gains, back-feeding gains at today’s corn price would lower payback to 6 crop season in 15’ tile and 8 years in 30’ tile patterns.

Figure 3. Gate Structures to Control Water Table



In 2021, observed yield gains from back-feeding were +9.1 and +7.7 Bu/A. respectively.

It should be noted that NETAFIM® drip tape was used as the primary irrigation source for all treatments and the back-feeding of water for secondary irrigation. We did this mainly because back-feeding of water in tile does not allow the use of fertigation. Applying nutrients such as N, P, or K could contaminate water supply, so tile is used for water irrigation only. The NETAFIM® drip tape is used for additional water as well as fertigation.

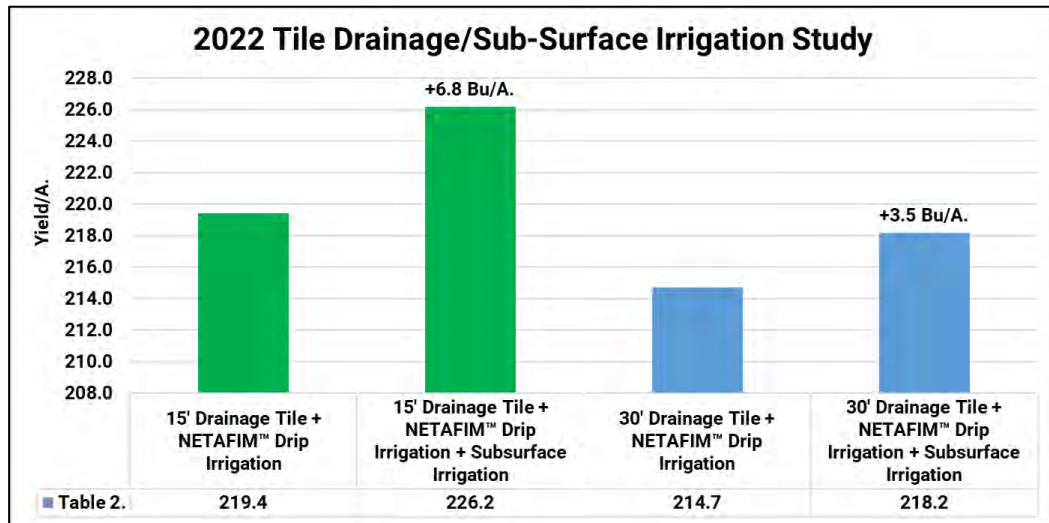

High Management Corn Strip Cropping Study

Objective: To achieve high yield corn in an intense management environment with proper field drainage, irrigation and sound practical and realistic agronomic practices. This trial utilizes the water recycling system at the PTI Farm to drain saturated soils when wet and then recycles that rainwater to irrigate and fertigate with in hot dry summer months. The field protocol for high yield consisted of the following:

1. Strip-Cropping:

- Alternating blocks of corn and soybeans
- Both crops in 15" rows, in 15' wide "blocks"
- Outside 4 Rows: 54K Seed Rate Inside Rows: 44K

2. At-Plant Conceal® Dual Band Placement

- 15 Gal 32% UAN
- 3 Gal Nachurs® KFuse®(6-0-12-12)
- 3 Gal/A. Ammonium ThioSulfate
- 3.2oz/A. Envita®

3. Irrigation/Fertigation

- 6.25" Rainfall fed by NETAFIM® Drip Tape
- 5Gal/A. Ammonium ThioSulfate
- 3 Qts/A. 10% Boron
- 5 Gal QLF Agronomy BOOST™ (4-0-3-2S)

4. Rantizo® Spray UAV Foliar Feed/Protection Program

- V3: Source™ 0.7oz/A.
- V10: 1 Gal Nachurs® KFuel®(0-0-24)
- V10: 1Qt Nachurs® FinishLine®(8-4-6+Micros)
- VT: 13.7 oz Miravis®Neo + 1# Marco NutriComplete
- R1: 4Gal/A. QLF Agronomy Amino 15™ (15-0-1)
- R3: 13.7oz TrivaPro®



High Management Corn Strip Cropping Study

Results: The control in the study is dryland, non-strip-crop, and status quo low management corn planted at 36K and fertilized with only dry 9-23-30 and 180# nitrogen. Table 1. illustrates yield results of all entries in the study.

In the high management program, yields ranged from a low of 285 Bu/A. to a high of 398.4 Bu/A. In the past four years at the PTI Farm, 368.2 had been our highest yield recorded. 2022 broke that yield level with three entries, all over the 368.2 threshold. Average corn yield in the irrigated entries resulted in 335.4 Bu/A.

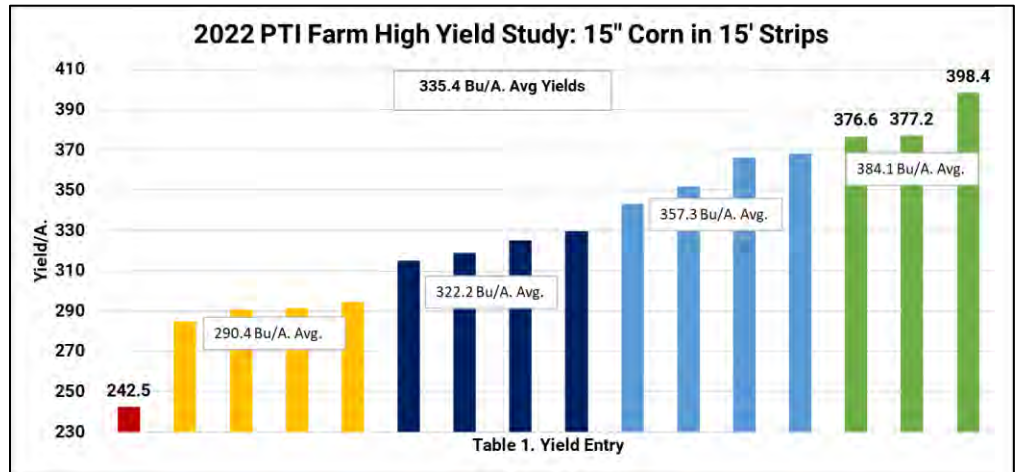
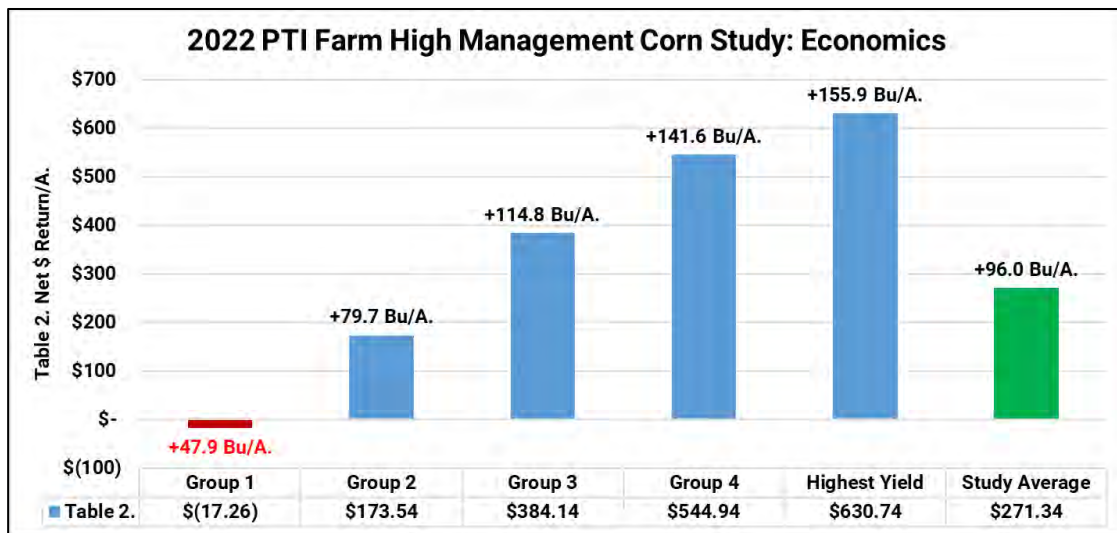

Table 2. looks specifically at economics of the high management study. High yield is important in this trial, but economics must tell us that it's cost effective and sustainable to continue doing. Break-even yield needed compared to control yield was 293.5 Bu/A.

Group 1 lowest entries recorded +47.9 Bu/A. yield gains, but failed to reach break-even by **-2.9** resulting in losses of **-\$17.26/A.** However, all other groupings exceeded break-even by a range of +28.9 Bu/A. to +105.1 Bu/A. with actual yield gains of +79.7 to 155.9 Bu/A. On average, the high yield entries recorded yield advantages of +96.0 Bu/A., with net returns of +\$271.34/A. over the control. Consequently, positive net returns were realized ranging from +\$173.54/A. to +\$630.74/A.



High Management Corn Strip Cropping Study

Table 3. illustrates the yield effect of the strip-cropping practice. By utilizing a tall crop of corn, alternating in blocks with a short crop of soybeans, corn yield can excel due to increased photosynthesis. Outside corn rows next to soybeans resulted in yield gains on average of +49.2 Bu/A., with north planted rows achieving slightly higher yields of +14.3 Bu/A. compared to south planted rows.

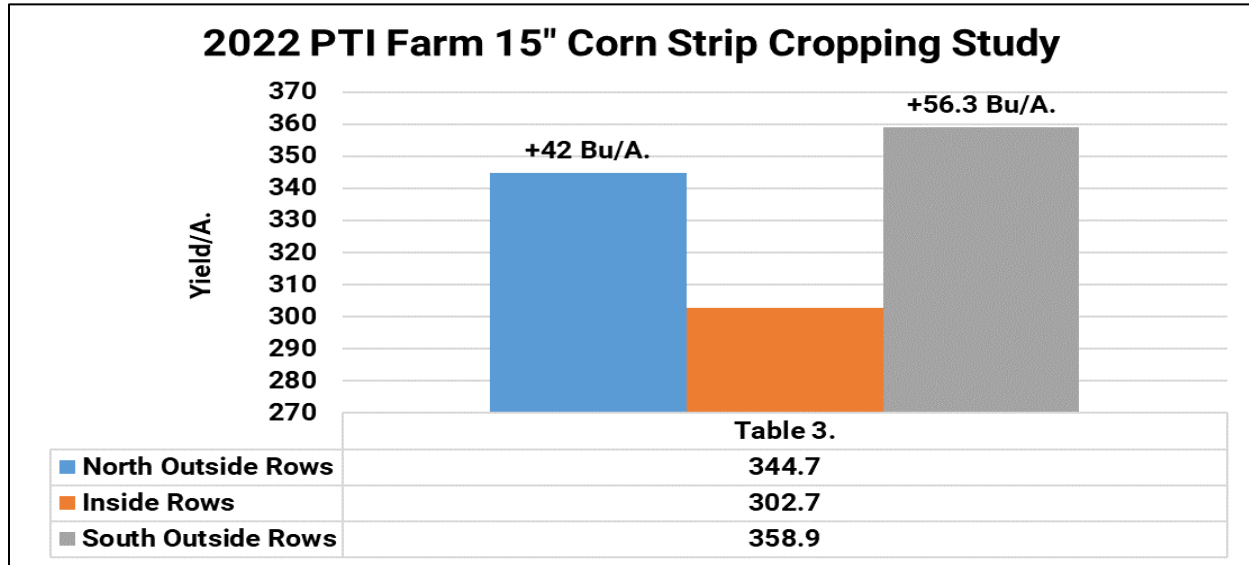

Planting Date: May 14th Channel 212-04, 209-15 Population: Varied Row Width: 15" Rotation: Varied Corn Price: \$6.00 Conceal® Program: \$46.45 /A.
 Nitrogen: \$93.21/A High Yld N: 299.5# Control N: 180# Foliar Program: \$44.94/A. Fert Reallocation: \$30/A. Seed: \$56.25/A. Irrigation/Fert: \$81.81/A.

The Anderson's® High Management Corn Nutritional Study

Objective: To evaluate the yield and economic impact of a corn liquid starter fertilizer and foliar nutritional program from The Andersons® in a high management irrigated environment. This trial consisted of the following:

Treatments and Placement:

#1. Control:	No Irrigation, Only Foliar VT + R3 Foliar Fungicide
#2 At-Plant Fertility:	
Conceal® Dual Band: (Figure 1.)	1 Gal/A. Eezy® K, 1Qt/A. Tri Z™ Pro, 16oz/A. Eezy® MolyB 5 Gal 9-24-3, 27 Gal/A. 32% UAN
FurrowJet® Center: (Figure 2.)	2 Gal/A. Season Pass® Diamond 6-18-6 with MicroCarb® 1pt BioPass™, 2pt/A. Corn Mix II
FurrowJet® Wings: (Figure 2.)	3 Gal/A. Season Pass® Diamond 6-18-6 with MicroCarb® 2 Gal/A. Water
#3 Foliar Applications:	
	V3: 1Qt MicroBlitz®, 1Qt MicroCarb®, 1Gal FirstPass®
	V4: SideDress: 2 Gal Eezy® K, 20 Gal 32% UAN
	V5: 1Pt PhosFix®, 1Pt SweetNEezy™
	V10: 2Qt Korrekt® Plus, 1Qt MicroBlitz®
	V10: EZ Drop: 2Qt Korrekt® Plus, 1Pt Eezy™ Moly-B
	VT: 1 Gal OverPass® 22-0-2, 1Pt SweetNEezy™
R3: 1 Gal OverPass® 22-0-2, 1Pt SweetNEezy™	

Figure 1. Conceal Placement



Figure 2. FurrowJet® Placement



The Anderson's® Corn Nutritional Study Continued

Irrigation on all treatments (excluding control) received 6.25" Rain throughout the growing season, as well as 5 Gal/A. Ammonium thiosulfate 12-0-0-26S + 2 Gal/A. 10% Boron as fertigation thru the V10-VT growth stages. All treatments were initially planted on April 28th, but replanted on June 15th. No at-plant fertility was additionally applied at replant. All treatments received 13.7oz/A. of Miravis® Neo at VT and 13.7oz/A. of TrivaPro® at R3 growth stages.

Results: Irrigated treatments contributed +52.4 average yield gains. Foliar treatments offered 6.4 Bu/A. gains over stand-alone at-plant FurrowJet®/Conceal® applications (Table 1).

Table 2. illustrates economic returns of both treatments in a high management environment versus a status quo low management program. After all costs, the high management program increased net returns by +\$31.90 to +\$97.80/A.

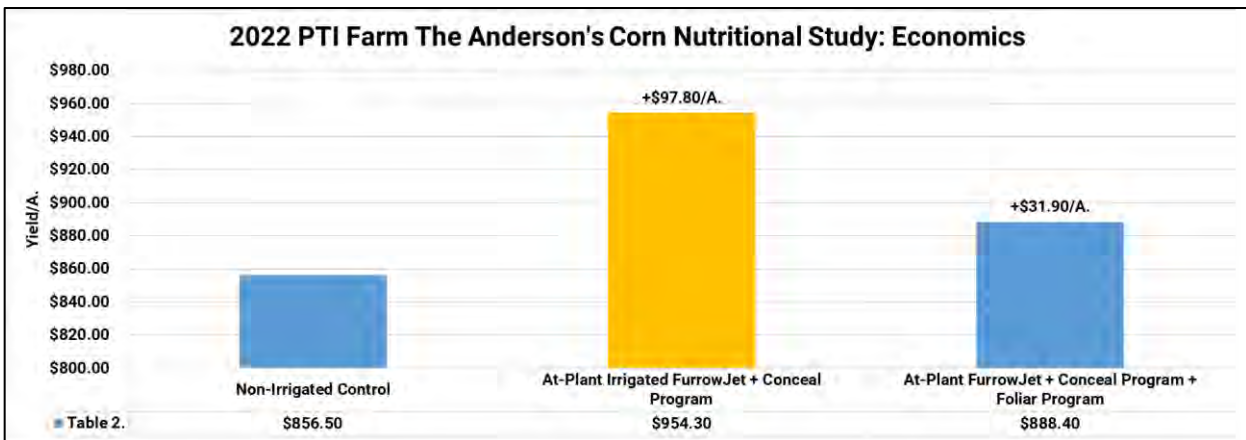
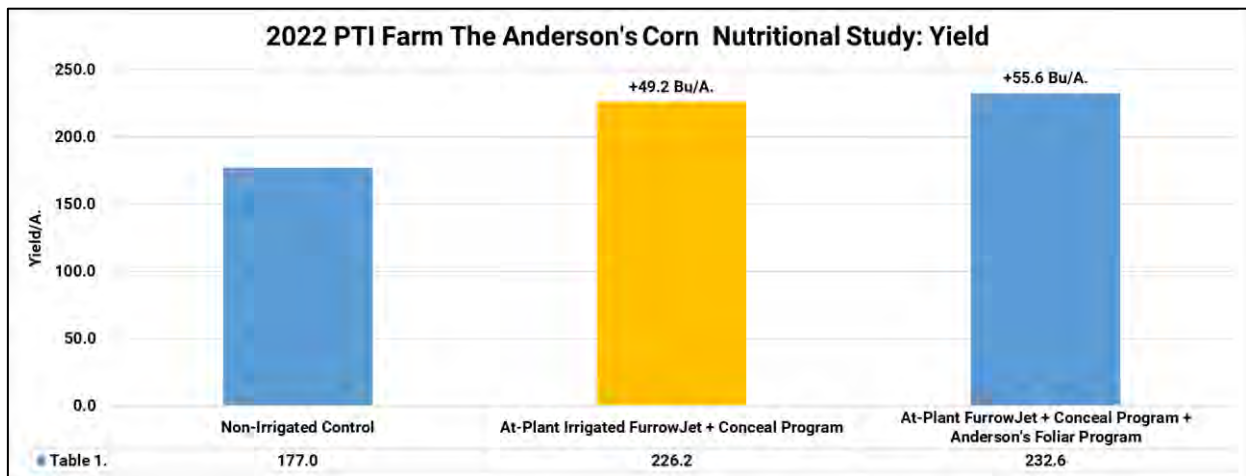

Planting Date: June 15th DKC 56-65, Golden Harvest® 03R40, 02K73, AgriGold® 639-70 Population: 36K Row Width: 30" Rotation: CAB Corn Price: \$6.00
 Conceal® Program: \$48.37 /A. FurrowJet® Program: \$54.28/A Foliar Program: \$104.30/A. Fert Reallocation: \$30/A. Irrigation: \$40/A. Fertigation + N: \$84.75/A

AgroLiquid® High Management Corn Nutritional Study

Objective: To evaluate the yield and economic impact of a corn liquid starter fertilizer and foliar nutritional program from AgroLiquid in a high management irrigated environment. This trial consisted of the following:

Treatments and Placement:

#1. Control:	No Irrigation, Only Foliar VT + R3 Foliar Fungicide
#2 At-Plant Fertility:	
Conceal® Dual Band: (Figure 1.)	2 Gal/A. accesS™, 27 Gal/A. 32% UAN
FurrowJet® Center: (Figure 2.)	2 Gal/A. ProGerminator® 3Qt/A. Micro500™
FurrowJet® Wings: (Figure 2.)	3 Gal/A. SpringUp® 2 Gal/A. Kalibrate® 1Pt/A. Boron
#3 Foliar Applications:	
	V4: SideDress: 1 Gal/A. SpringUp®, 2 Gal/A. accesS™
	V4 SideDress: 1Pt/A. Boron, 1Qt/A. CTech, 20 Gal/A. 32%
	V8: 2 Gal/A. FertiRain®, 1Qt/A. Micro500™, 1Qt/A. Fulvic Acid
	V8: 2 Gal/A. eNhance™, 1Pt/A. Boron
	VT: 13.7 oz/A. Miravis® Neo Fungicide
	R3: 13.7 oz/A. TrivaPro® Fungicide

Figure 1. Conceal Placement



Figure 2. FurrowJet® Placement

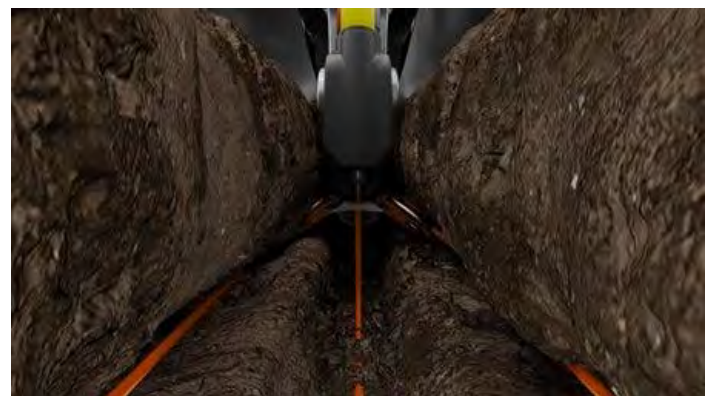

AgroLiquid® Corn Nutritional Study Continued

Irrigation on all treatments (excluding control) received 6.25" Rain throughout the growing season, as well as 5 Gal/A. Ammonium thiosulfate 12-0-0-26S + 2 Gal/A. 10% Boron as fertigation thru the V10-VT growth stages. All treatments were initially planted on April 28th, but replanted on June 15th. No at-plant fertility was additionally applied at replant. All treatments received 13.7oz/A. of Miravis® Neo at VT and 13.7oz/A. of TrivaPro at R3 growth stages.

Results: Irrigated treatments contributed +38.0 Bu/A. average yield gains. Foliar treatments offered 11.4 Bu/A. gains over stand-alone at-plant FurrowJet®/Conceal® applications (Table 1).

Table 2. illustrates economic returns of both treatments in a high management environment versus a status quo low management program. After all costs, the high management program increased net returns by +\$32.47 to +\$33.04/A.

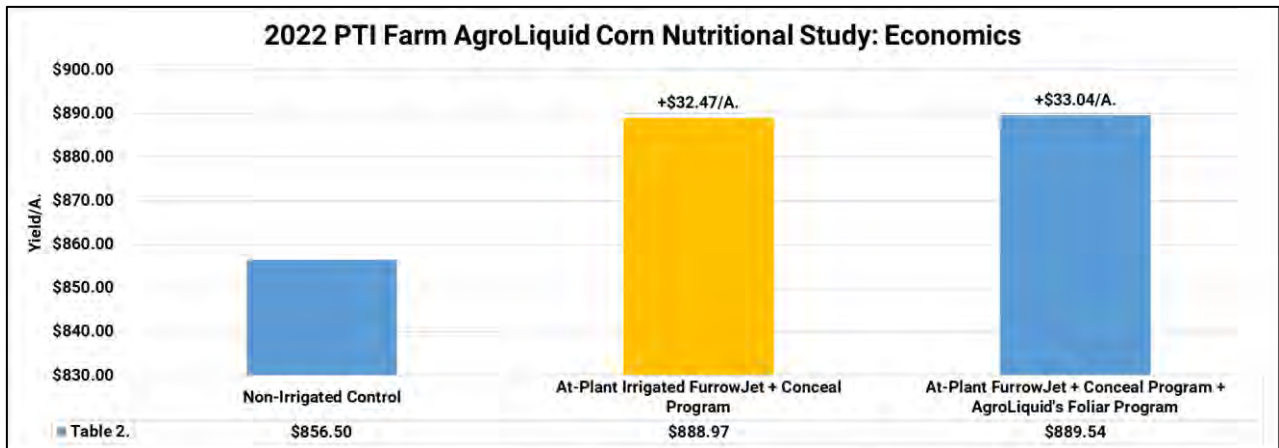
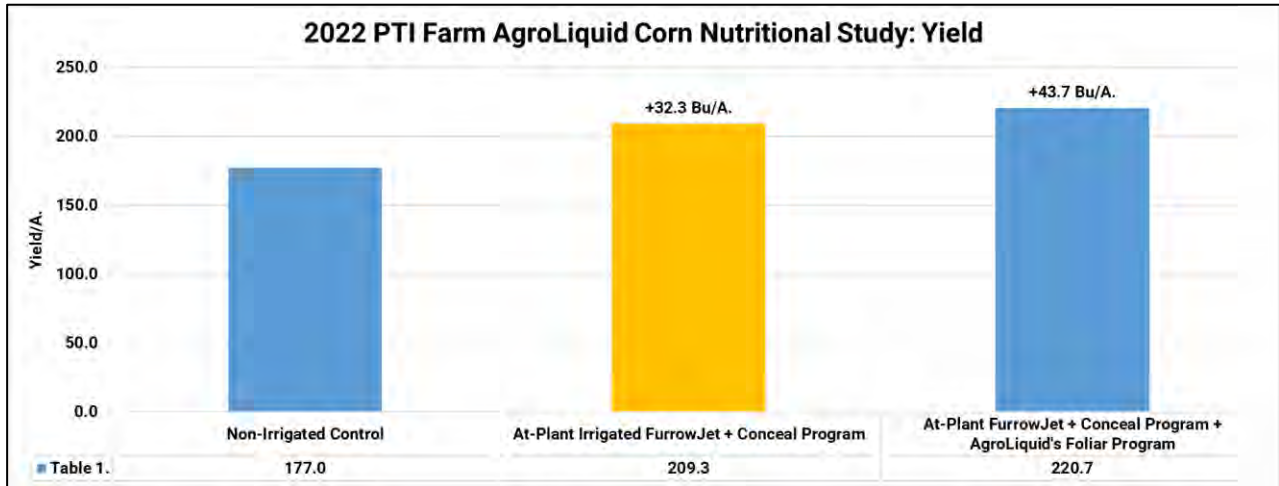

Planting Date: June 15th DKC 56-65, Golden Harvest® 03R40, 02K73, AgriGold® 639-70 Population: 36K Row Width: 30" Rotation: CAB Corn Price: \$6.00
 Conceal® Program: \$13.55/A. FurrowJet® Program: \$53.03/A Foliar Program: \$67.83/A. Fert Reallocation: \$30/A. Irrigation: \$40/A. Fertigation + N:

Marco Fertilizer High Management Corn Nutritional Study

Objective: To evaluate the yield and economic impact of a corn liquid starter fertilizer and foliar nutritional program from Marco Fertilizer in a high management irrigated environment. This trial consisted of the following:

Treatments and Placement:

#1. Control:	No Irrigation, Only Foliar VT + R3 Foliar Fungicide
#2 At-Plant Fertility:	
Conceal® Dual Band (Figure 1.)	27 Gal/A. NitroK Complete
FurrowJet® Center: (Figure 2.)	12.8oz TerraMax MicroAZ-IF Liquid Inoculant
FurrowJet® Wings: (Figure 2.)	3 Gal/A. QuickGrow Complete
	3 Gal/A. Water
#3 Foliar Applications:	
	V4: SideDress 20 Gal NitroK Complete
	V5: 1# NutriComplete 8-12-40
	V10: 1# NutriComplete 8-12-40
	VT: 1# NutriComplete + 13.7oz/A. Miravis®Neo
	R3: 1# NutriComplete + 13.7oz TrivaPro®

Figure 1. Conceal Placement



Figure 2. FurrowJet® Placement

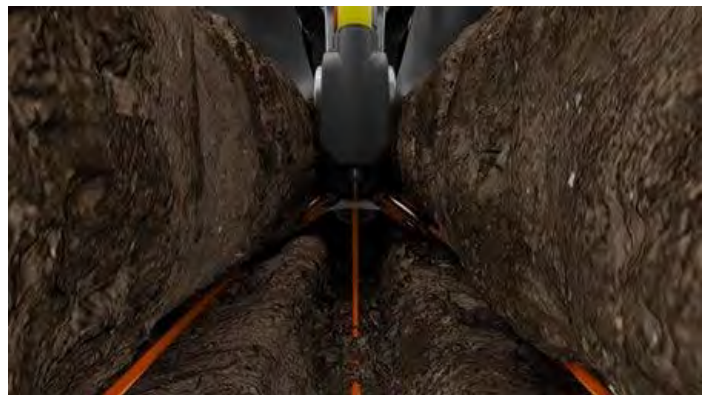

Marco Fertilizer Corn Nutritional Study Continued

Irrigation on all treatments (excluding control) received 6.25" of rain throughout the growing season, as well as 5 Gal/A. Ammonium thiosulfate 12-0-0-26S + 2 Gal/A. 10% Boron as fertigation thru the V10-VT growth stages. All treatments were initially planted on April 28th, but replanted on June 15th. No at-plant fertility was additionally applied at replant. All treatments received 13.7oz/A. of Miravis® Neo at VT and 13.7oz/A. of TrivaPro® at R3 growth stages.

Results: Irrigated treatments contributed +37.25 Bu/A. average yield gains. Foliar treatments offered 8.7 Bu/A. gains over stand-alone at-plant FurrowJet®/Conceal® applications (Table 1).

Table 2. illustrates economic returns of both treatments in a high management environment versus a status quo low management program. After all costs, the high management program increased net returns by +\$58.67 to +\$70.07/A.

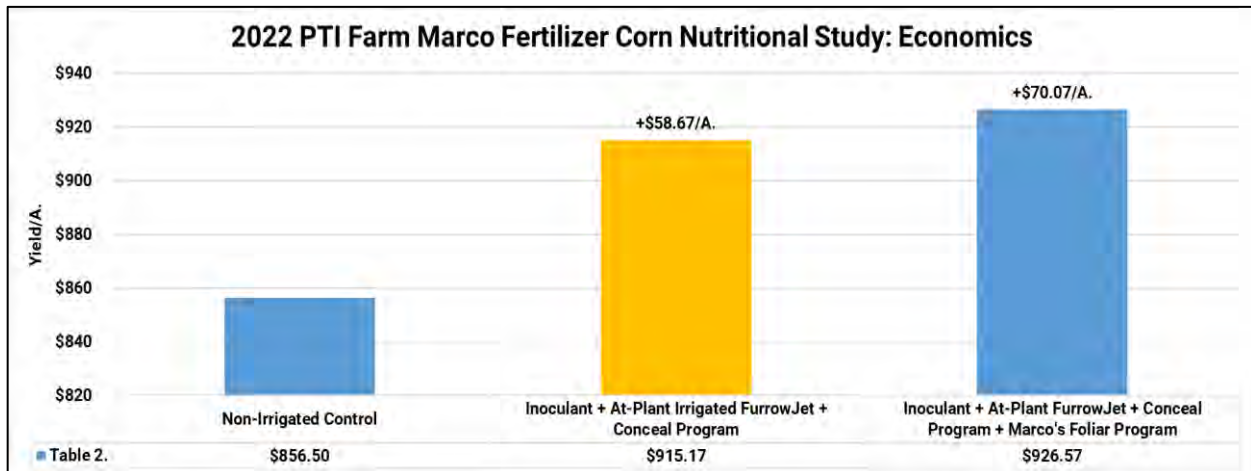
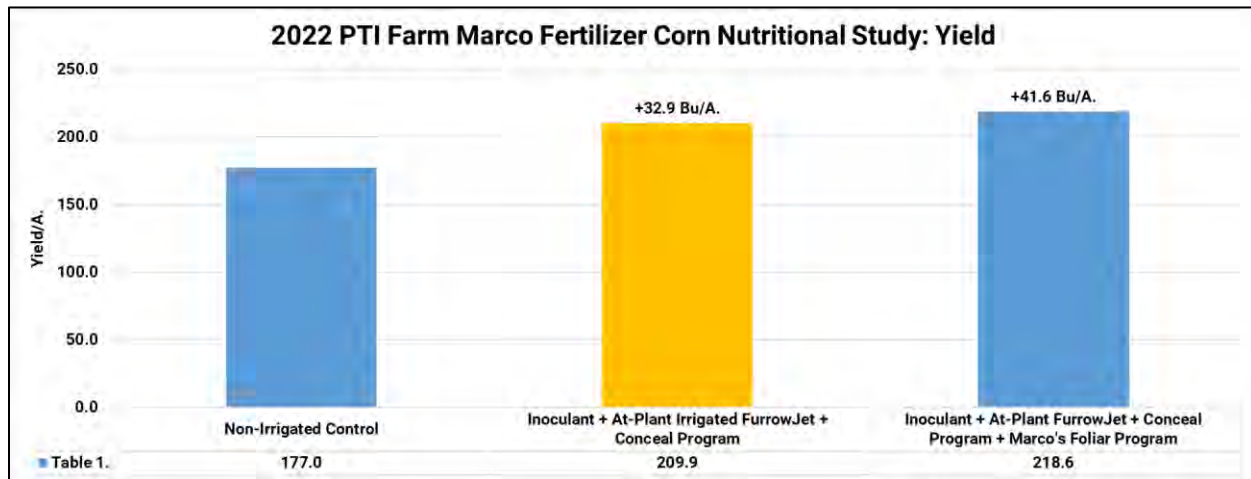

Planting Date: June 15th DKC 56-65, Golden Harvest® 03R40, 02K73, AgriGold® 639-70 Population: 36K Row Width: 30" Rotation: CAB Corn Price: \$6.00
 Conceal® I Program: \$19.98/A. FurrowJet® + Inoculant Program: \$24/A Foliar Program: \$40.80/A. Fert Reallocation: \$30/A. Irrigation: \$40/A. Fertigation + N: \$84.75/A

Stoller® USA Fertilizer High Management Corn Nutritional Study

Objective: To evaluate the yield and economic impact of a corn liquid starter fertilizer and foliar nutritional program from StollerUSA in a high management irrigated environment. This trial consisted of the following:

Treatments and Placement:

#1. Control:	No Irrigation, Only Foliar VT + R3 Foliar Fungicide
#2 At-Plant Fertility:	
Seed Treatment:	2oz/cwt BioForge® Premier
Conceal® Dual Band (Figure 1.)	27 Gal/A. 32% UAN, 5 Gal/A. 10-34-0, 3 Gal/A. ATS
FurrowJet® Center: (Figure 2.)	4oz/A. Fortified Stimulate Yield Enhancer® 1Qt/A. Charge 12%™
FurrowJet® Wings: (Figure 2.)	1Qt/A. Harvest Plus™
#3 Foliar Applications:	
	V4: 4oz Fortified Stimulate®, 8oz BioForge® Advanced
	V6: 2.5#/A. UreaMate®, 8oz/A. Xcyte™
	V10: 1Qt Harvest Plus™, 1Qt/A. Nitrate Balancer
	VT: 1 Qt/A. Sugar Mover® Premier, 8oz/A Xcyte™, + 2.5# Harvest More® Urea Mate
	VT: 13.7 oz/A. Miravis® Neo Fungicide
	R2: 16oz/A. Xcyte™, 2.5# Urea Mate®
R4: 13.7 oz/A. TrivaPro® Fungicide, 1Pt/A. Xcyte™, 1Pt Force	

Figure 1. Conceal Placement



Figure 2. FurrowJet® Placement

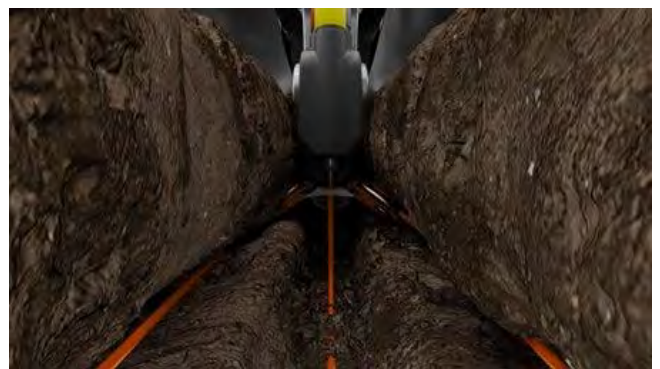

Stoller® USA Fertilizer Corn Nutritional Study Continued

Irrigation on all treatments (excluding control) received 6.25" Rain throughout the growing season, as well as 5 Gal/A. Ammonium thiosulfate 12-0-26S + 2 Gal/A. 10% Boron as fertigation thru the V10-VT growth stages. All treatments were initially planted on April 28th, but replanted on June 15th. No at-plant fertility was additionally applied at replant. All treatments received 13.7oz/A. of Miravis® Neo at VT and 13.7oz/A. of TrivaPro® at R3 growth stages.

Results: Irrigated treatments contributed +35.5 to +55.8 Bu/A. average yield gains. Foliar treatments offered 20.3 Bu/A. gains over stand-alone at-plant seed treatment and FurrowJet®/Conceal® applications (Table 1).

Table 2. illustrates economic returns of both treatments in a high management environment versus a status quo low management program. After all costs, the high management program increased net returns by +\$36.41 to +\$39.64/A.

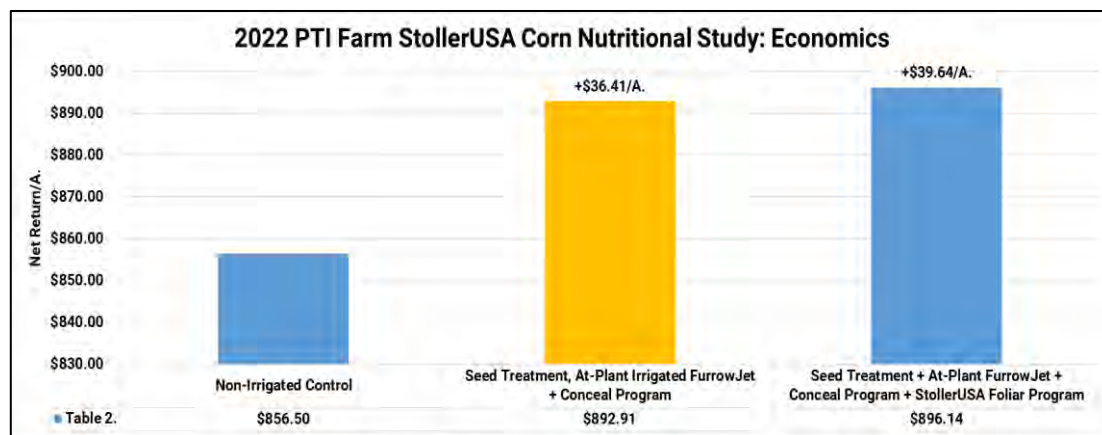
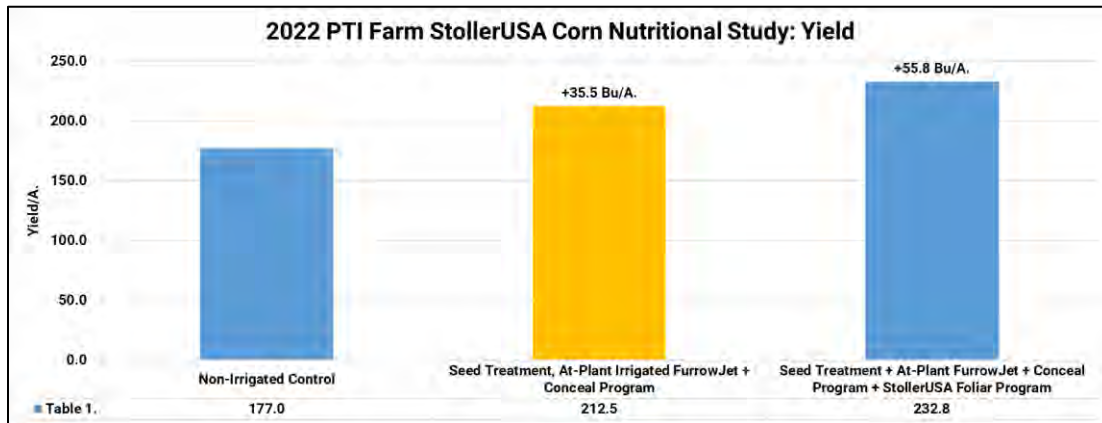

Planting Date: June 15th DKC 56-65, Golden Harvest® 03R40, 02K73, AgriGold® 639-70 Population: 36K Row Width: 30" Rotation: CAB Corn Price: \$6.00
 Conceal® Program: \$60.55/A. FurrowJet® Program: \$21.29/A Foliar Program: \$118.57/A. Fert Reallocation: \$30/A. Irrigation: \$40/A. Fertigation + N:

Nachurs® High Management Corn Nutritional Study

Objective: To evaluate the yield and economic impact of a corn liquid starter fertilizer and foliar nutritional program from Nachurs® in a high management irrigated environment. This trial consisted of the following:

Treatments and Placement:

#1. Control:	No Irrigation, Only Foliar VT + R3 Foliar Fungicide
#2 At-Plant Fertility:	
Conceal® Dual Band (Figure 1.)	27 Gal/A. UAN, 5 Gal/A. Nachurs Throwback® 3 Gal/A. K-fuse®, 0.5 Gal/A. Nachurs SideSwipe®
FurrowJet® Center: (Fig. 2.)	1Qt Rhyzo-Link® PE, 1.5 Gal/A. Balance®, 2Qt/A. Nachurs K-fuel®
FurrowJet® Wings: (Fig. 2.)	6 Gal/A. Nachurs First Down®, 1Qt/A. Nachurs Humi-Flex Max®
#3 Foliar Applications:	
	V4: 1Qt FinishLine®, 2Gal TripleOption®, 1Pt Hum-flex®FA
	V6: SideDress 2 Gal Nachurs K-flex® Max, 0.5 Gal Nachurs SideSwipe®
	V10: 1 Gal Nachurs K-fuel®, 1Qt Nachurs FinishLine®
	V12: Fertigation: 4 Gal Nachurs K-fuel®, 0.5 Gal SideSwipe
	VT: 13.7oz/A. Miravis®Neo
	VT: 1 Gal FirstDown®+ 1 Gal Balance®
	R2: 1Qt Nachurs Humi-Flex® FA
	R3: 13.7oz TrivaPro®
	R3: Fertigation: 4 Gal Aqua-Tech®



Figure 1. Conceal Placement



Figure 2. FurrowJet® Placement

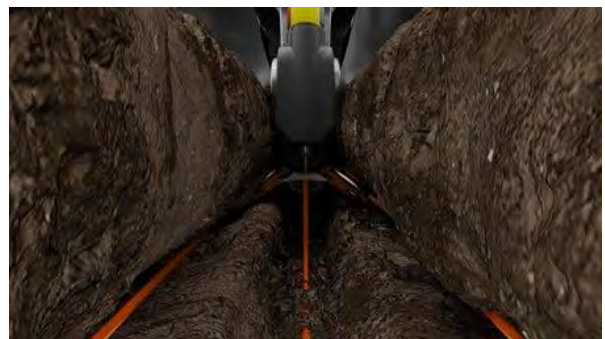

Nachurs® Fertilizer Corn Nutritional Study Continued

Irrigation on all treatments (excluding control) received 6.25" of rain throughout the growing season. All treatments were initially planted on April 28th, but replanted on June 15th. No at-plant fertility was additionally applied at replant. All treatments (including control) received 13.7oz/A. of Miravis® Neo at VT and 13.7oz/A. of TrivaPro® at R3 growth stages.

Results: Table 1. illustrates irrigated treatments overall contributed +52.9 Bu/A. average yield gains. Foliar treatments offered 18.5 Bu/A. gains over stand-alone at-plant FurrowJet®/Conceal® applications.

Economics indicate at-plant resulted in losses of **-\$1.42/A.**, while full combination treatments gained positive returns of +\$27.20/A. Due to late re-planting, an over-all high yield of 220 to 239 Bu/A. corn was not achievable to sustain the program cost of this high management program.

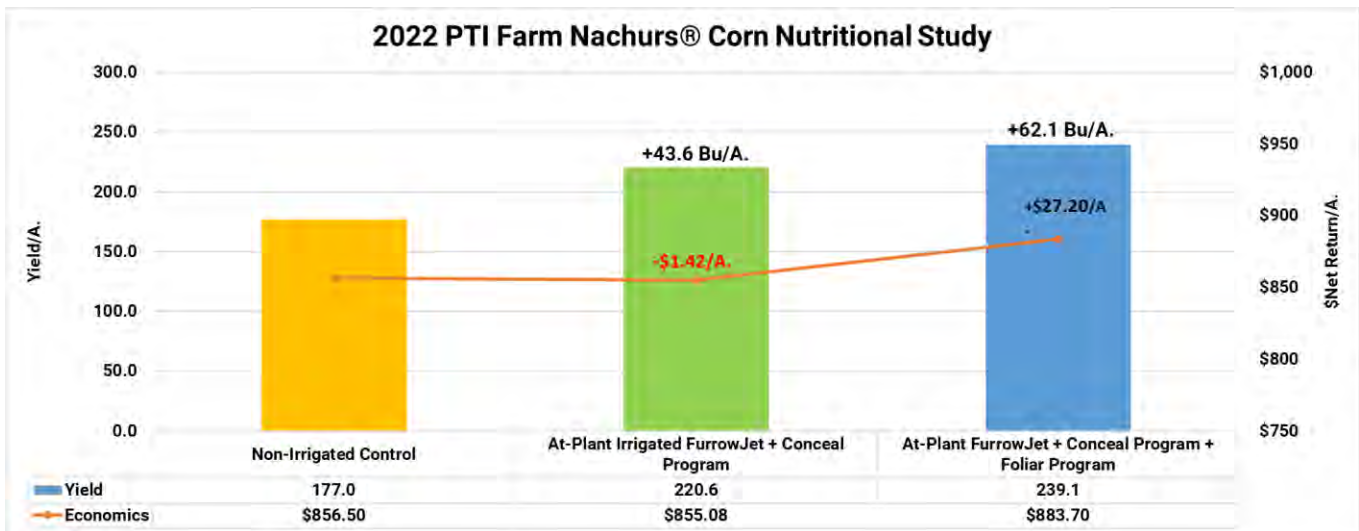

Brandt® Fertilizer High Management Corn Nutritional Study

Objective: To evaluate the yield and economic impact of a corn liquid starter fertilizer and foliar nutritional program from Brandt in a high management irrigated environment. This trial consisted of the following:

Treatments and Placement:

#1. Control:	No Irrigation, Only Foliar VT + R3 Foliar Fungicide
#2 At-Plant Fertility: Conceal® Dual Band (Figure 1.)	27 Gal/A. 32% UAN 5 Gal/A. BRANDT® 5-12-0 1Qt/A. BRANDT® Uptake® Starter 1Qt/A. BRANDT® EnzUp® 2 Qt/A. BRANDT® Liquid Boron 10%
#3 Foliar Applications: 	V3: 2 Qt/A. BRANDT® Smart Trio® VT: 13.7oz Miravis® Neo + 1Qt/A. BRANDT® SmartKB™ R3: 13.7oz/A. TrivaPro® + 1Qt/A. BRANDT® SmartKB™

Figure 1. Conceal Placement



Brandt® Corn Nutritional Study Continued

Irrigation on all treatments (excluding control) received 6.25" Rain throughout the growing season, as well as 5 Gal/A. Ammonium thiosulfate 12-0-0-26S + 2 Gal/A. 10% Boron as fertigation thru the V10-VT growth stages. All treatments were initially planted on April 28th, but replanted on June 15th. No at-plant fertility was additionally applied at replant. All treatments received 13.7oz/A. of Miravis® Neo at VT and 13.7oz/A. of TrivaPro® at R3 growth stages.

Results: Irrigated treatments contributed +43.0 Bu/A. average yield gains. Foliar treatments offered 9.1 Bu/A. gains over stand-alone at-plant Conceal® applications.

The table below illustrates economic returns of both treatments in a high management environment versus a status quo low management program. After all costs, the high management program increased net returns by +\$71.60 to +\$86.67/A.

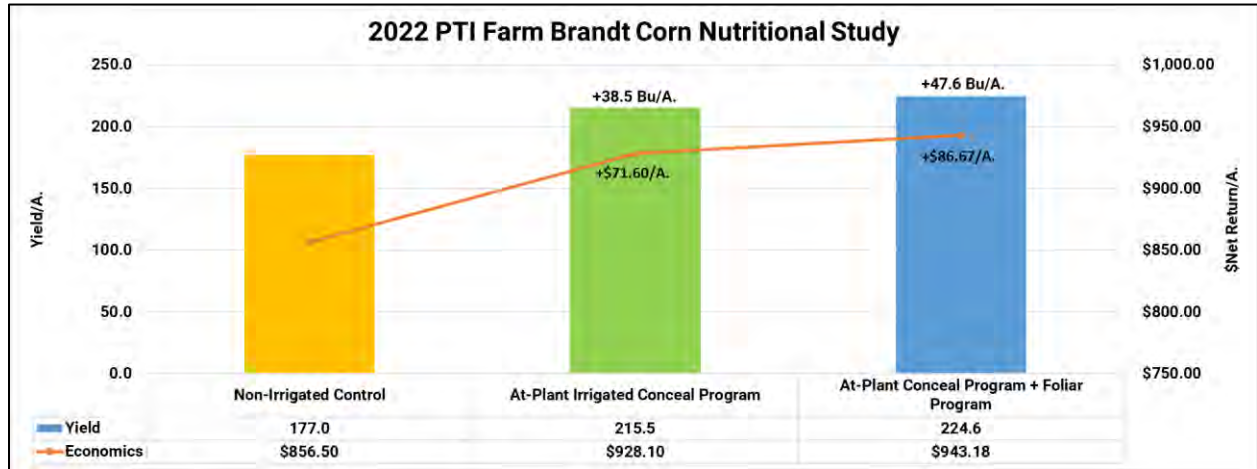

NMS LLC High Management Corn Nutritional Study

Objective: To evaluate the yield and economic impact of a corn liquid starter fertilizer and foliar nutritional program from Nutrient Management Specialists in a high management irrigated environment. This trial consisted of the following:

Treatments and Placement:

#1. Control:	No Irrigation, Only Foliar VT + R3 Foliar Fungicide
#2 At-Plant Fertility:	
Conceal® Dual Band (Figure 1.)	5Gal/A. 10-52-4, 2#/A. 20-20-20, 1 Gal/A. WholeShot
FurrowJet® Center: (Figure 2.)	3.2oz/A. Envita® 2 Gal/A. Compost Tea
FurrowJet® Wings: (Figure 2.)	16oz/A. Macrosorb RZT 2 Gal/A. Pacific Gro/Yucca 2 Gal/A. Sea Crop
#3 Foliar Applications:	
	V5: 2 Gal/A. 10-52-4 w/micros, 3 Gal/A. WholeShot
	V5: 1 Gal/A. PacificGro Yucca, 64oz High Energy Fish
	V5: 15oz/A. 16% Humic Acid, 2 Gal/A. Compost Tea
	V5: 24oz SeaCrop
	V12: 18oz/A. Big Shot, 1 Gal/A. Whole Shot, 1 Gal/A. Yucca
	V12: 1 Gal/A. Compost Tea, 16oz/A. SeaCrop
	V12: 0.5 Gal/A. Potassium Acetate

Figure 1. Conceal Placement



Figure 2. FurrowJet® Placement



NMS LLC Corn Nutritional Study Continued

#3 Foliar Applications Continued:



- Brown Silk: 2.5#/A. 20-20-20, 1 Gal/A. Whole Shot
- Brown Silk: .75Gal/A. Pacific Gro/Yucca
- Brown Silk: .75 Gal/A. High Energy Fish, 24oz/A. Sea Crop
- Brown Silk: 2 Gal/A. Potassium Acetate
- Brown Silk: 0.5#/A. Boron

Irrigation on all treatments (excluding control) received 6.25" Rain throughout the growing season, as well as 5 Gal/A. 15oz/A. of a Humic Acid, 0.5# Boron and 32oz/A. potassium acetate as fertigation.

All treatments were initially planted on April 28th, but replanted on June 15th. No at-plant fertility was additionally applied at replant. All treatments received 13.7oz/A. of Miravis® Neo at VT and 13.7oz/A. of TrivaPro® at R3 growth stages.

Results: Irrigated treatments contributed +42.2 Bu/A. average yield gains. Foliar treatments offered 15.1 Bu/A. gains over stand-alone at-plant FurrowJet®/Conceal® applications.

The table below illustrates economic returns of both treatments in a high management environment versus a status quo low management program. After all costs, the high management program increased net returns by +\$35.15 to **-\$11.98/A.**

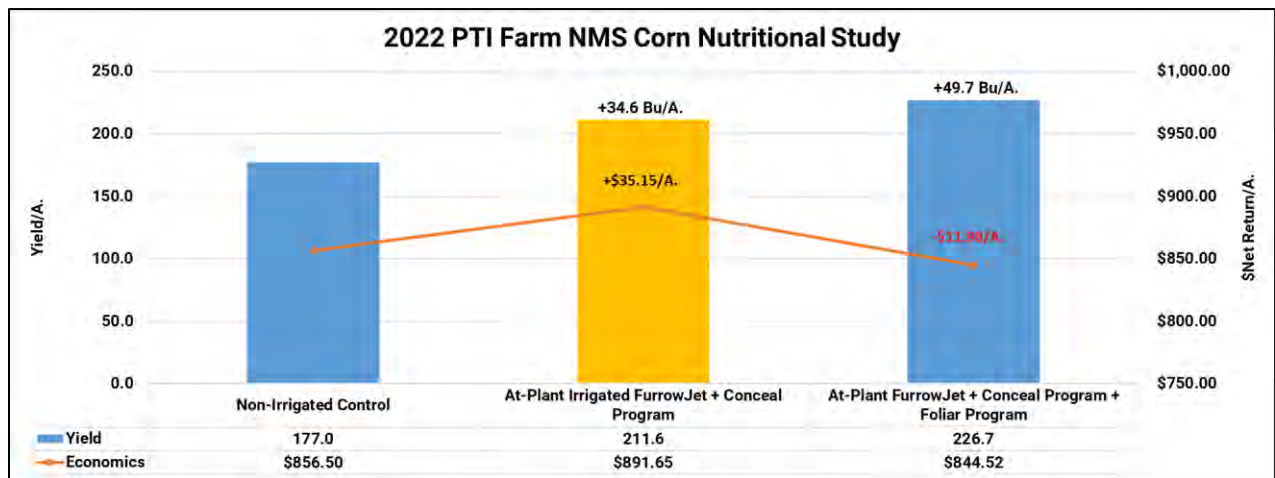

Marco Fertilizer/QLF™ At-Plant High Management Corn Study

Objective: To evaluate the yield and economic impact of a corn liquid starter fertilizer and foliar nutritional program from Marco Fertilizer and QLF™ Agronomy in a high management irrigated environment.

All treatments were initially planted on April 28th but replanted on June 15th. No at-plant fertility was additionally applied at replant. 5.0" of rainfall was applied via NETAFIM® drip irrigation.

This trial focuses on evaluating the following individual planter treatments:

Treatments and Placement:

#1. Control:	Irrigation + Full Foliar Program
#2 At-Plant Conceal® Dual Band: (Figure 1.)	20 Gal/A. UAN, 1 Gal/A. 10% Boron 4 Gal/A. QLF™ BOOST™ 10 Gal/A. Marco NutriStart BOOST 14-12-4-6S
#3 At-Plant FurrowJet® Center: (Figure 2.)	1 Gal/A. Purple Cow Organics CX-1 1 Gal/A. QLF™ 5-5-5-1S 1Pt QLF™ Kelpak® Double Strength
#3 At-Plant FurrowJet® Wings: (Figure 2.)	5 Gal/A. Marco QuickGrow LTE 6-20-4-2.7S-.25Zn 1 Gal/A. QLF BOOST™



Figure 1. Conceal Placement

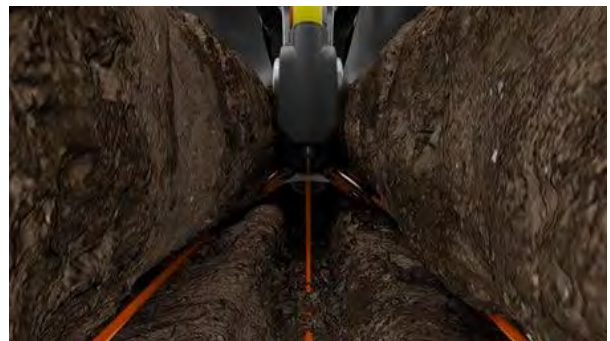

Figure 2. FurrowJet® Placement



Marco Fertilizer/QLF™ At-Plant High Management Corn Study

Foliar Applications:	V4:	1 Gal QLF Amino-15™ 15-0-1-0.5S, 1Pt QLF Kelpack®PRO
All Treatments	V3:	3 Gal QLF Amino-15™, 1 Qt QLF PowerAid micros
	V10:	3 Gal QLF Amino-15™, 1# Marco NutriComplete
	V10:	Fertigation: 1 Gal 10% Boron, 1 Gal QLF BOOST™
	VT:	13.7oz/A. Miravis®Neo
	VT:	1# Marco NutriComplete, 3 Gal QLF Amino-15™
	R3:	13.7oz TrivaPro®
	R3:	1 Gal QLF BOOST™, 1Pt Live Earth Fulvic Acid

Results: Table 1. Illustrates individual yield response by treatment. All treatments achieved positive yield gain, however full combination treatments offered highest yield response of +22.2 Bu/A. at 245.8 Bu/A. Conceal® treatments offered the highest individual contribution with gains of +13.3 Bu/A., while FurrowJet® treatments resulted in yield gains ranging gains of +3.8 to +8.7 Bu/A. respectively.

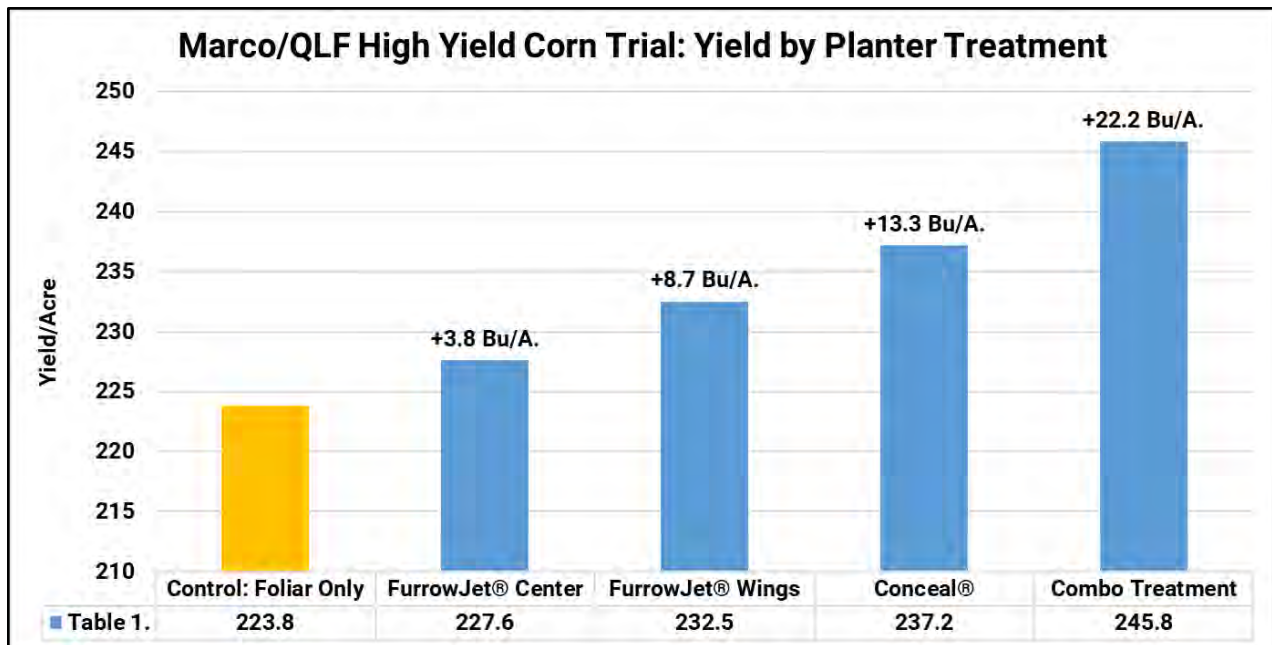

Marco Fertilizer/QLF™ At-Plant High Management Corn Study

Table 2. illustrates individual return on investment response by treatment. All treatments obtained positive return on investment ranging from +\$34.79 to +\$52.92/A.

However, FurrowJet® wing treatments of Marco QuickGrow LTE + 1 Gal QLF BOOST™ proved highest returns of +\$52.92/A.

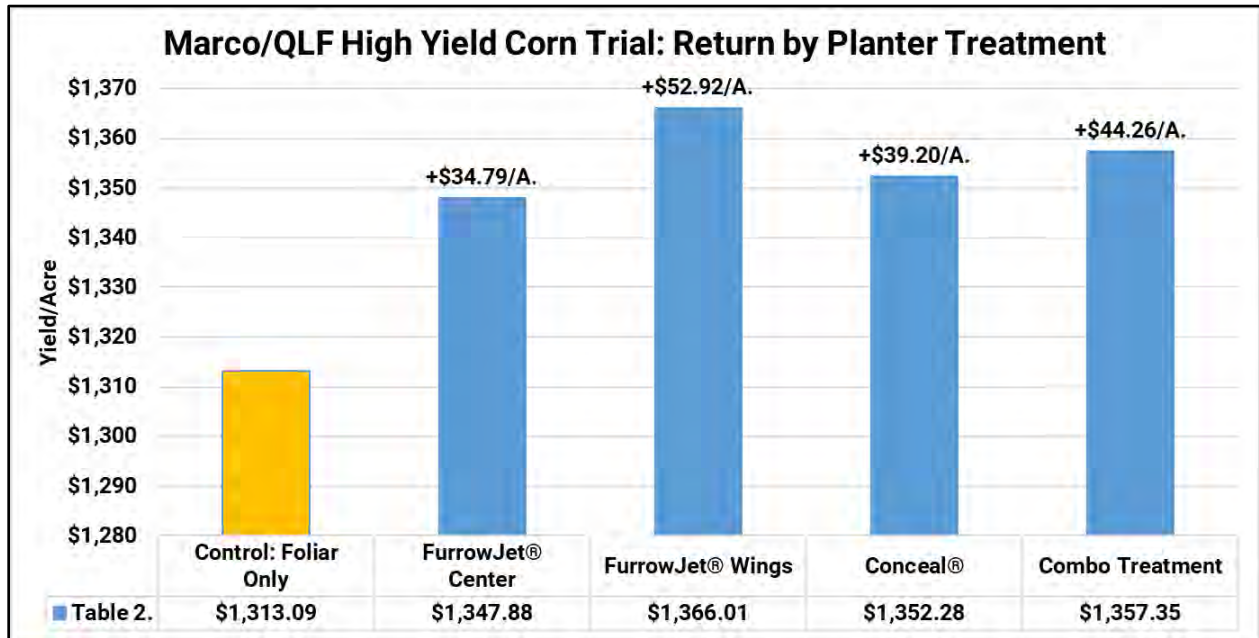

Planting Date: June 15th Hybrid: Pioneer® 0306Q Population: 36K Row Width: 30" Rotation: CAB Corn Price: \$6.00

Conceal® Program: \$70.84/A. FurrowJet® Center Program: \$17.80/A FurrowJet® Wing Program: \$29/A. Fert Reallocation: \$30/A.

High Management Corn Ocean Blue Ag Fertility Study

Objective: To evaluate the yield and economics of Ocean Blue Ag’s corn nutrition program. This high management fertility study implements the use pre-plant dry calcium, sea salt, at-plant FurrowJet® and Conceal® liquid nutrition, as well as foliar liquid applications at V3, VT, and R1 growth stages.

SandyCal by Calcean, is a 94-98% pure calcium carbonate and is applied as a broadcast pre-plant and is raw natural aragonite sand mine from the ocean near the beaches of the Bahamas

Sea-90™ by SeaAgri, Inc are natural salt crystals produced from sea water mined from the Sea of Cortez in Mexico. It is dehydrated seawater in its purest state containing 75-80 percent sodium chloride containing 90 plus elements including sodium, potassium, calcium, and magnesium and balanced with trace elements including copper, chromium, zinc, manganese, selenium, cobalt, molybdenum.

Elevation 0-5-0 is an early V3 foliar feed that contains long lasting bio-stimulated catalyst and phosphoric acid that helps pollination, blossom retention and fruiting.

Grain Gain 0-5-0 is a VT foliar feed that is a reproductive energizer and catalyst that improve test weight, insect and disease resistance and better grain fill.

Nutri-Shield 0-7-0 is applied in-furrow and contains vitamin hormone enzymes, rooting acids, chelated trace minerals, and humic acids. It helps provide for immediate growth energy, promotes stronger roots and suppresses insect feeding.

Power Pro N is applied as a tank-mix with 32% UAN at side-dress and is a soil nutrient enhancer and natural nitrogen stabilizer that revives soil microbiology, and improves nitrogen efficiency.

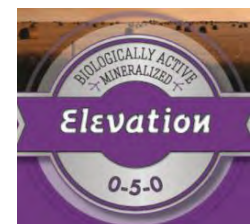

Ocean Blue Ag Fertility High Management Study

The following treatments were made as a part of a sequential step-up program to help evaluate single applied programs as well as combination programs:

All treatments were initially planted on April 28th but replanted on June 15th. No at-plant fertility was additionally applied at replant.

<u>Program</u>	<u>Treatment</u>	<u>Application Timing</u>	<u>Placement of Fertilizer</u>
1	Control	None	None
2	750# Aragonite	Pre-Plant	Broadcast Spinner
3	75# Sea-90	Pre-Plant	Broadcast Spinner
4	80oz Nutri-Shield FurrowJet® 80oz Power Pro Conceal® V3 Sidedress 180oz Power Pro	At-Plant In-Furrow At-Plant Conceal® Side-Dress N	FurrowJet® Tri-Band Conceal® Dual Band Center Knife w/Sealer
5	80oz Nutri-Shield FurrowJet® 80oz Power Pro Conceal® V3 Sidedress 180oz Power Pro 64oz Elevation Grain Gain	At-Plant In-Furrow At-Plant Conceal® Side-Dress N V3 VT	FurrowJet® Tri-Band Conceal® Dual Band Center Knife w/Sealer Foliar Broadcast Spray Foliar Broadcast Spray
6	Program #5 + Aragonite	Pre-Plant At-Plant In-Furrow At-Plant Conceal® Side-Dress N V3 VT	Broadcast Spinner FurrowJet® Tri-Band Conceal® Dual Band Center Knife w/Sealer Foliar Broadcast Spray Foliar Broadcast Spray
7	Combination Treatments of #2,#3, and #5	Pre-Plant Pre-Plant At-Plant In-Furrow At-Plant Conceal® Side-Dress N V3 VT	Broadcast Spinner Broadcast Spinner FurrowJet® Tri-Band Conceal® Dual Band Center Knife w/Sealer Foliar Broadcast Spray Foliar Broadcast Spray

*All treatments received foliar treatment of fungicide at VT growth stage.

Ocean Blue Ag Fertility High Management Study Continued

Results: Table 1. Summarizes all Ocean Blue Ag products proved positive yield gains ranging from +0.3 Bu/A. to +11.5 Bu/A. Single treatment yield response varied from +0.3 to +5.9 Bu/A., while combination treatments proved highest yield response with gains of +11.4 to +11.5 Bu/A.

Table 2. illustrates the telling story around the economics of the treatments. While all treatments provided positive yield gains, only three treatments proved positive net returns.

Dry broadcast treatments of Sandy Cal aragonite and Sea-90 proved net revenue gains of +\$5.77/A. and +\$9.02/A., however application charges could most likely offset these gains.

FurrowJet® and Conceal® treatments of NutriShield and PowerPro proved the largest return in the study proving +\$19.96/A. net gains.

Combination treatments, although provided highest yield response in the study, failed to prove positive returns with losses of **-\$8.29/A.**, **-\$42.12/A.** and **-\$63.70/A.** respectively.

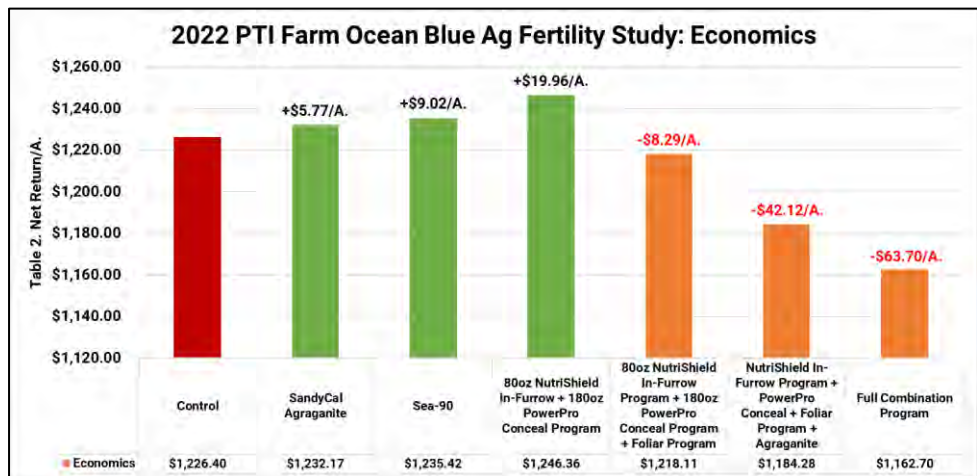
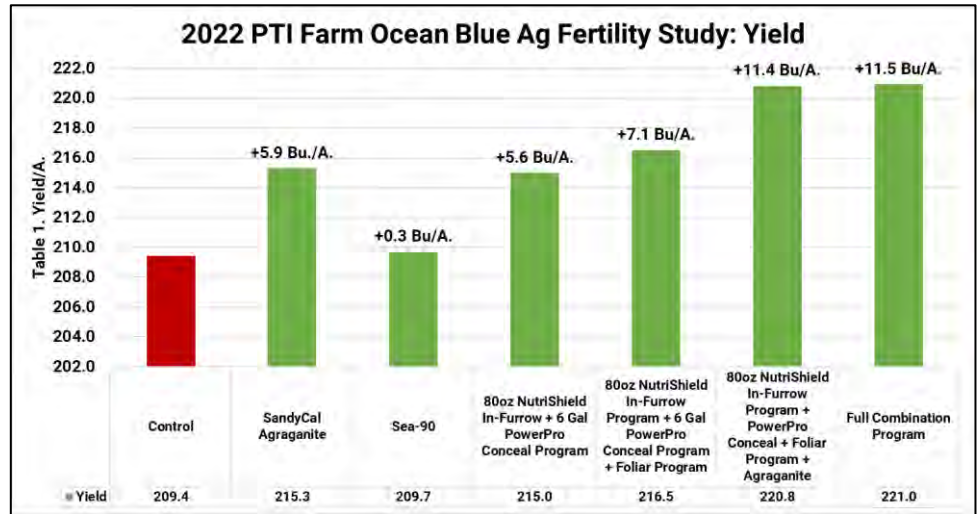

Planting Date: June 15th Hybrid: GH 03R40 Population: 36K Row Width: 30" Rotation: CAB Corn Price: \$6.00 \$30 Fertilizer Reallocation

SandyCal Agranite: \$59.63/A. PowerPro: \$24.83/A. NutriShield: \$18.81/A Grain Gain: \$22.20/A. Elevation: \$15.05/A. Sea-90: \$22.78/A.

Marco QuickGrow LTE FurrowJet® Study

Objective: To evaluate the yield and net return of Marco Fertilizer’s QuickGrow LTE 6-20-4-.25Zn-2.7S liquid starter fertilizer at rates of 4, 6 and 8 Gal/A. applied in an at-plant 3-way FurrowJet® system. QuickGrow LTE is a 70% polyphosphate and 30% orthophosphate formulation of nitrogen, phosphorus, potassium, sulfur, and 9% Zn.

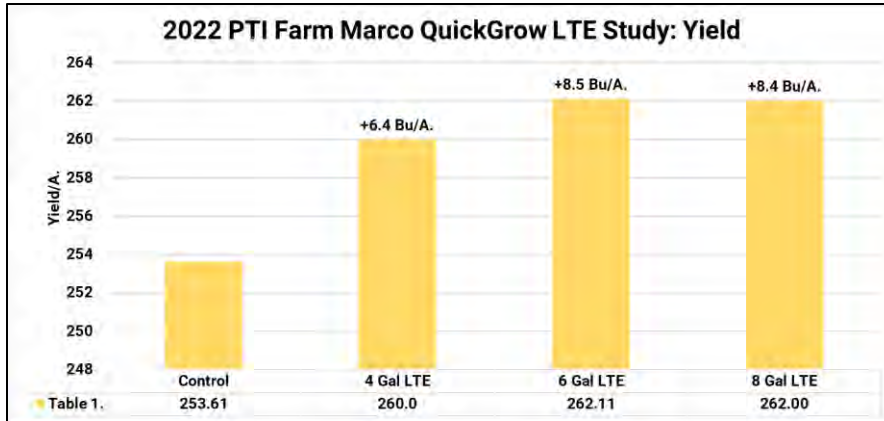
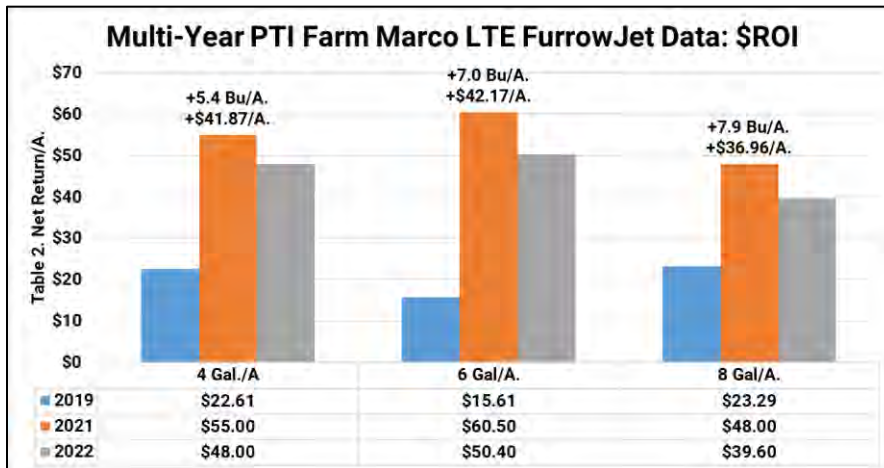

Figure 1. FurrowJet® Placement



Results: Table 1. illustrates all rates of Marco QuickGrow LTE resulted in positive yield gains. However, 6 Gal/A. rates achieved both agronomic and economic optimum rate, with yield gains of +8.5 Bu/A. and net returns of +\$50.40/A.

Table 2. summarizes multi-year data, indicating 6 Gal/A. being economic optimum rate over the 2019, 2021, and 2022 time period. All applications are implemented with a \$30/A. reallocation.

NACHURS® imPulse® FurrowJet® Center Placement Trial

Objective: To evaluate the effect on yield and economics when NACHURS imPulse® 10-18-4 starter fertilizer (Figure 2.) is placed at 4 to 7 Gal/A. in FurrowJet® **center** only configurations (Figure 1). NACHURS imPulse® is a premium 100% orthophosphate in-furrow liquid fertilizer that contains NACHURS bio-K® technology.

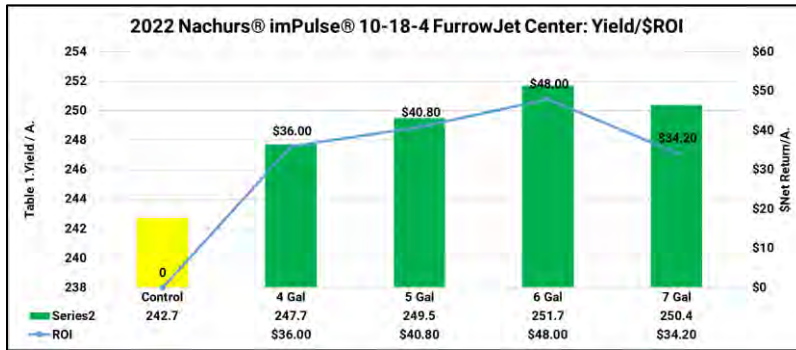

Figure 1. FurrowJet® Placement

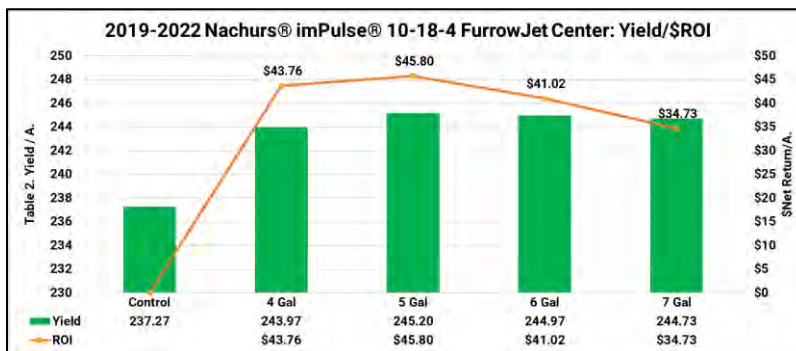

Figure 2. Nachurs imPulse® Starter

10-18-4 Liquid Fertilizer

Nutrients Supplied (pounds per gallon)

Total Nitrogen (N)	1.06
Available Phosphate (P ₂ O ₅)	1.91
Soluble Potash (K ₂ O)	0.42

Derived from: ammonium hydroxide, urea, phosphoric acid, potassium acetate, and potassium hydroxide.

Results: Table 1. illustrate rates of Nachurs imPulse® 10-18-4 at 6 Gal/A. achieved both agronomic and economic optimum rate with yield gains of +9.0 Bu/A. along with positive net returns of +\$48.00/A.

Table 2. illustrates multi-year data over 2019-2022 indicating the 5 Gal/A. rate as economic optimum over this time period, with an average return on investment of +\$45.80/A.



NACHURS® Start2Finish® Corn Fertility Trial



Objective: To evaluate the effect on yield and economics of NACHURS Start2Finish® corn fertility program. This 3-way program consists of the following treatments:

At-Plant: 5 Gal/A. Nachurs imPulse® applied via FurrowJet® 3-way

At-Plant: 2 Gal/A. K-Fuse® applied via Conceal® dual band

Foliar: 1 Qt/A. FinishLine® + 1Gal TripleOption®

Generations of America's Farmers have used NACHURS® liquid fertilizers because it is a quality brand they can trust. NACHURS® Bio-K® products offer the latest technology advancements farmers need to take their crops to the next level.

start finish 2™
The NACHURS® Bio-K® System for Maximizing Crop Yields

Simple yet effective, profitable yet sustainable, Start2Finish™ is a comprehensive liquid fertilizer program to maximize your crop's potential

NACHURS imPulse

NACHURS imPulse is a premium 100% orthophosphate in-furrow liquid fertilizer that contains NACHURS Bio-K technology, the most plant available source of potassium. Highly available phosphate and potassium promotes improved early season plant health and increased stress tolerance. Specially formulated for corn and wheat crops, NACHURS imPulse offers quick and uniform plant emergence which aids in achieving maximum yield potential.

NACHURS imPulse is seed safe when used at recommended rates, is non-corrosive to equipment, and has excellent cold-weather stability when stored properly (i.e. in flat bottom tanks).

NACHURS Finish Line

(8-4-6-0.1B-0.2Cu-1Mn-1Zn)

NACHURS Finish Line is a uniquely balanced foliar product with low use rates that have a proven record of increasing ROI on many crops. This foliar product is manufactured with the highest quality raw materials containing plant available orthophosphate, fully chelated micronutrients, surfactants, compatibility agents and organic acids as well as the latest potassium technology: NACHURS Bio-K. This ensures compatibility with most crop protection products and provides the best available nutrients essential for maximizing yield potential.*

NACHURS Triple Option

NACHURS Triple Option is a versatile NPKS liquid fertilizer that contains 100% orthophosphate, sulfur, and NACHURS Bio-K technology, the most plant available source of potassium. NACHURS Triple Option is a high orthophosphate fertilizer offering immediate nutrient availability. Adapted for use on all crops, NACHURS Triple Option offers the flexibility for in-furrow, foliar, fertigation, and transplant applications. It is also compatible with many crop protection products and other crop technologies, aligning to promote crop yield and quality.

Results: Tables 1-2 illustrate that Nachurs Start2Finish® proved agronomic gains of +9.5 Bu/A., along with positive economic gains of +\$31.44/A.

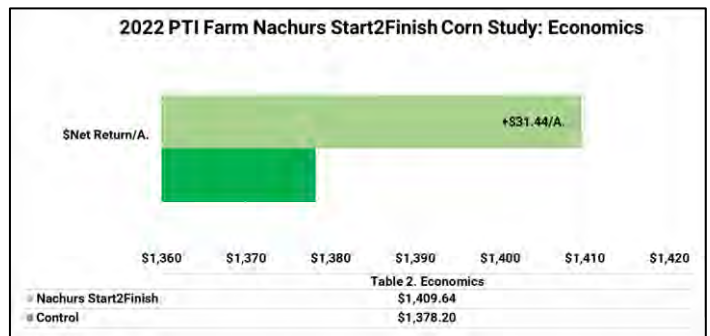
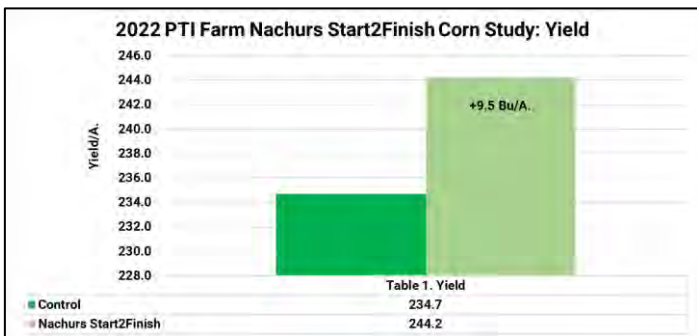

Planting Date: June 15th Hybrid: DKC 59-82 Population: 36K Row Width: 30" Rotation: CAB Corn Price: \$6.00

\$30/A Fert.Re-Allocation imPulse: \$6.00/Gal. K-Fuse: \$6.60/Gal. Finish Line:\$18.24/Gal TripleOption: \$7.80/Gal

Pivot Bio PROVEN®40 Nitrogen Mgt. Study

Objective: To evaluate the effect on yield and economics using Pivot Bio’s PROVEN®40, the first nitrogen-producing microbe for corn. Pivot Bio PROVEN® microbes are applied in-furrow during planting. These microbes create a symbiotic relationship with the corn plant, producing nitrogen and delivering it directly to the roots of the corn plant. Microbes then continually feed nitrogen to the corn plant throughout the growing season. Pivot Bio PROVEN®40 microbes adhere to the roots of the corn plant and support a reliable and consistent method for delivering plant nutrition. For this agronomic study, nitrogen rate is evaluated at 100% full rates (180#N) as well as -25% N reductions (135# total N or 45# N reduction). Pivot Bio PROVEN®40 was applied in-furrow at planting via FurrowJet® treatments (Figure 1).



Figure 1. FurrowJet® At-Plant



Results: Table 1. illustrates the control in the study being 100% nitrogen rates (180#N), offering base yields of 278.2 Bu/A. Reducing nitrogen by 45# (or 25%) resulted in losses of **-18.6 Bu/A**. However, when PROVEN®40 was added to that same nitrogen reduction rate of 135#N, yields were +0.4 Bu/A. better than the control rate of 180# N/A. Table 2. reveals the economics of the PROVEN®40 system. Stand-alone 25% nitrogen reductions resulted in economic losses of **-\$76.50/A**. PROVEN®40 applied via FurrowJet®, even with -25% N reductions, resulted in an economic profit of **+\$16.50/A**. over the

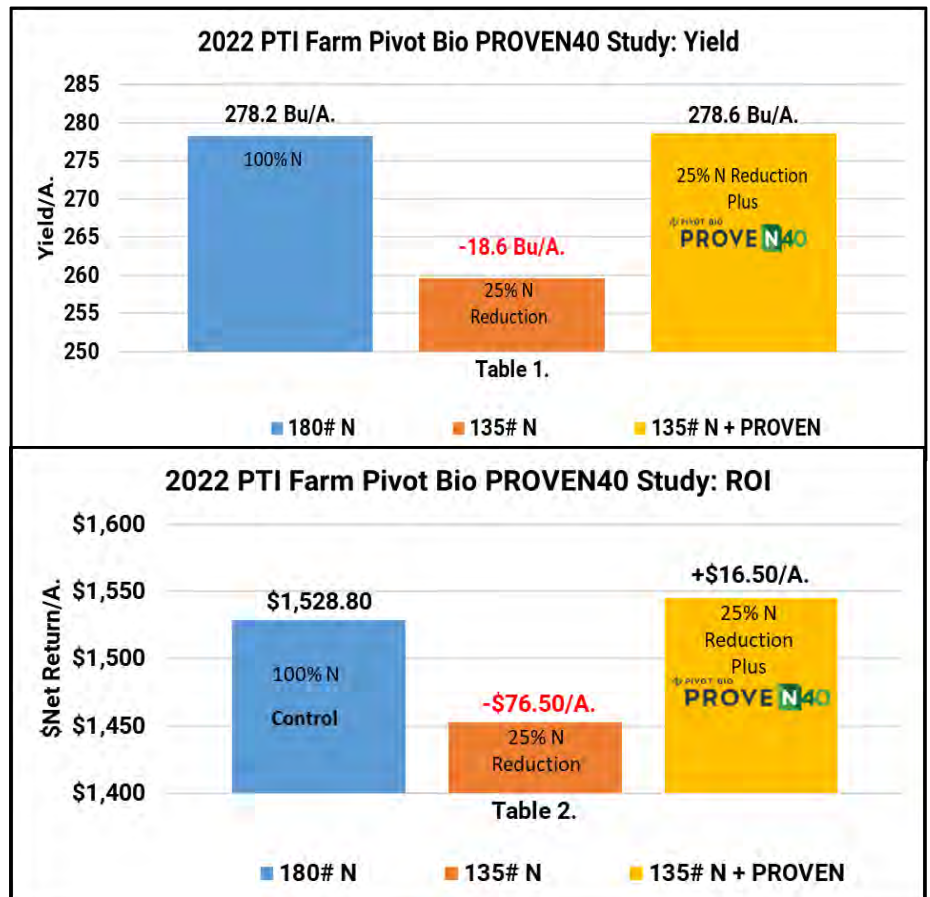

standard 180# N control rate.

Pivot Bio PROVEN®40 Nitrogen Mgt. Study Continued

A great feature of the Precision Planting PTI Farm is the ability to capture not just one year of data, but multiple years of data to get a better understanding of consistency and repeatability of a product or technology.

Tables 3-4. illustrate the three year data set summary of Pivot Bio PROVEN®40 over the years of 2020-2022. In this timeframe, reducing nitrogen rate by 40#N, along with the addition of PROVEN®40 applied via FurrowJet® has increased corn yield by +0.9 Bu/A. and has generated an additional +\$12.56/A. of farm family income.

In summary, PROVEN®40 has allowed the ability to lower nitrogen rate by 25% without losing corn yield, while at the same time increasing revenue by +\$12.56/A.

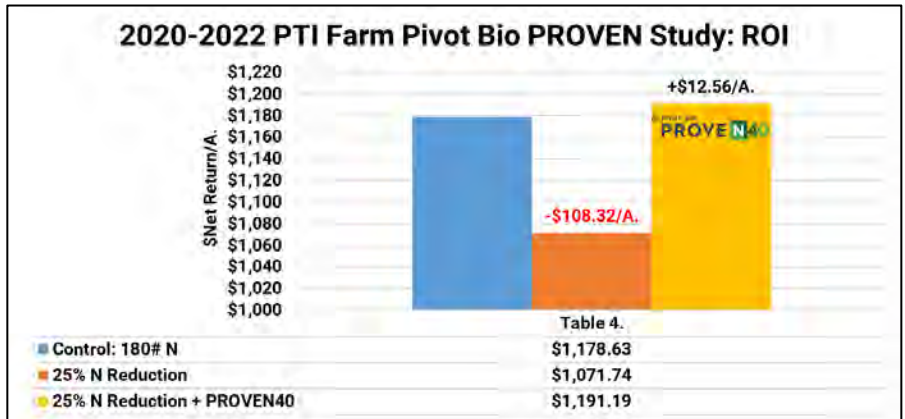
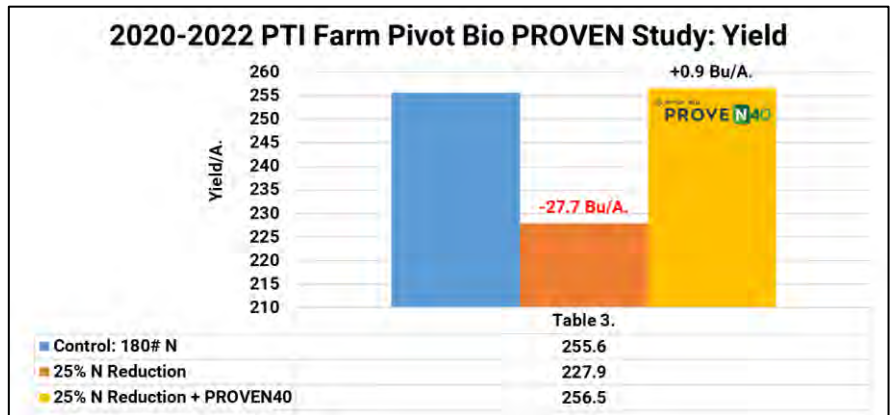
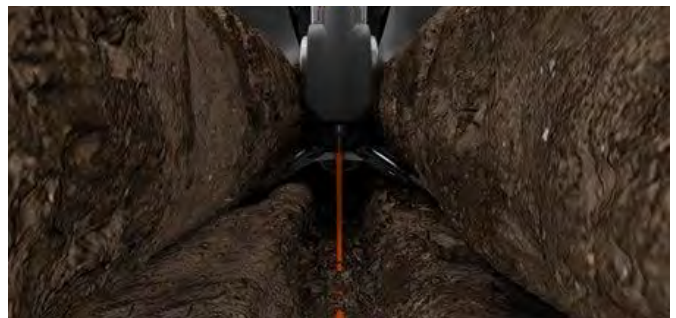

Figure 2. Precision Planting FurrowJet® At-Plant In-Furrow Application



Envita® Nitrogen Mgt. Study

Objective: To evaluate yield and economics of Envita®, applied in-furrow at planting in a FurrowJet® center only application (Figure 1).

Figure 1: FurrowJet® In-Furrow Application



Envita®, distributed by NewFields Ag™, is a naturally occurring, food-grade bacteria - *Gluconacetobacter diazotrophicus*, that was originally discovered in sugarcane. Envita® forms a symbiotic relationship with the host plant and provides nitrogen to cells throughout the plant, both above and below ground, all season long. The use of fertilizers and particularly nitrogen fertilizer is necessary for crop yield and quality. Soybeans and other legume crops have a natural ability to fix nitrogen through their root system, a process supported by rhizobia, which allows inoculated plants to create nodules that fix additional nitrogen in the soil. This practice is commonplace in soybean, but until now there has not been a similar solution for non-legume crops – now there is.

Results: Table 1. illustrates yield gains of +8.7 Bu/A. when Envita® was applied in-furrow along with a standard 100% nitrogen rate. When nitrogen rate was reduced by 10%, yield decreased by only 0.3 Bu/A.

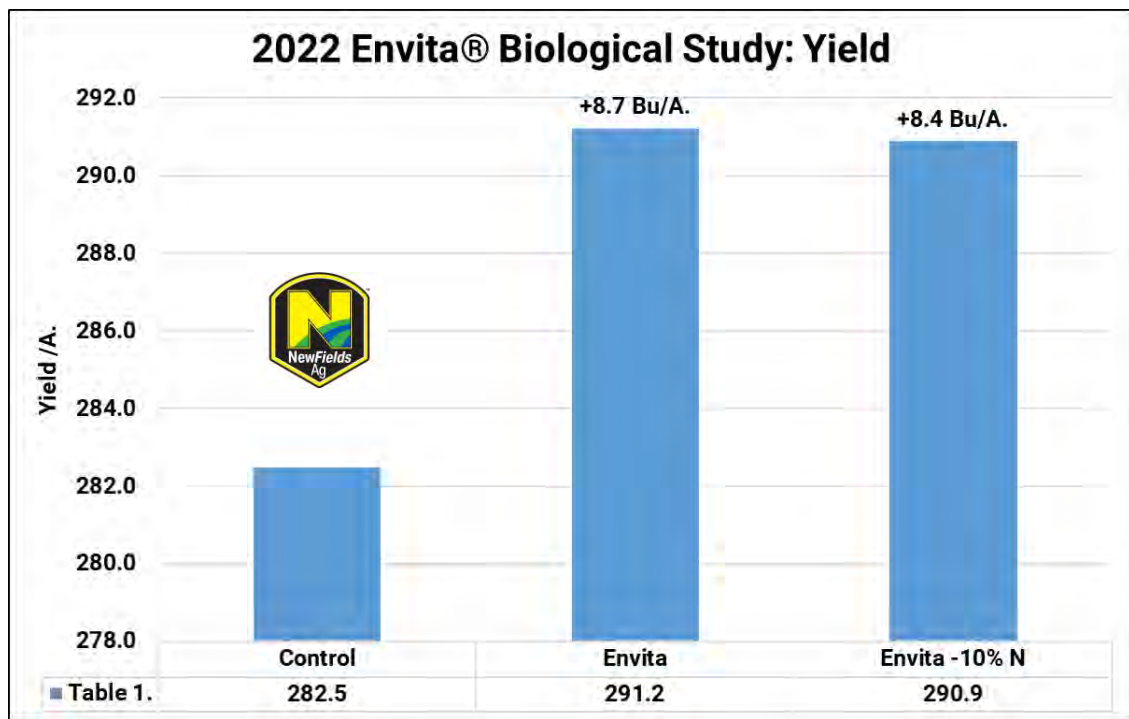

Envita® Nitrogen Mgt. Study Continued

Table 2. illustrates economic gains of +\$37.50/A. when Envita® was applied in-furrow along with a standard 100% nitrogen rate. When nitrogen rate was reduced by 10% in conjunction with Envita®, economic gains increased an additional +\$12.11/A.

Figure 1. illustrates treatments of Envita® vs control at V4 growth stage. Alternating blocks of Envita showed noticeable advantages of color, overall height and biomass.

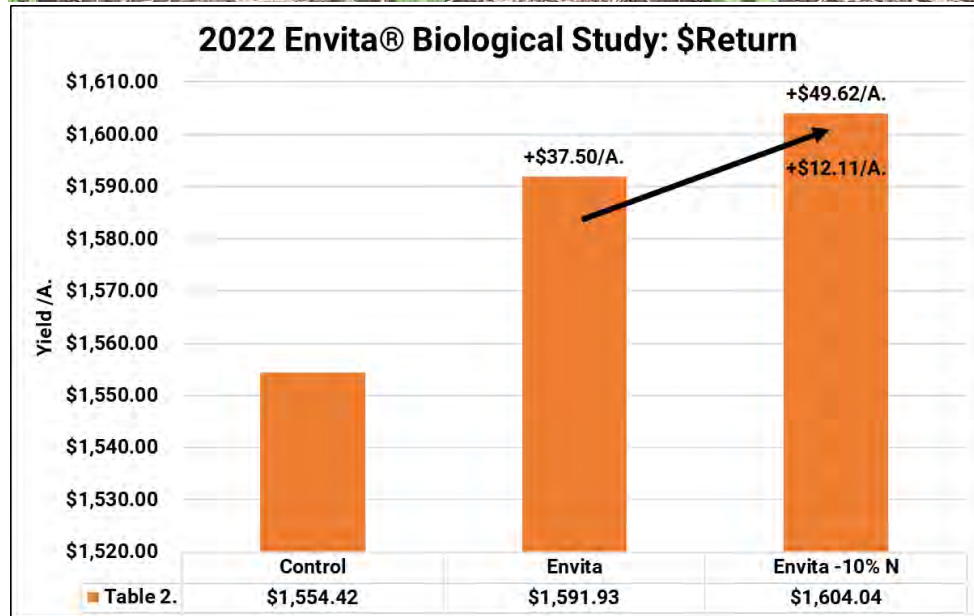
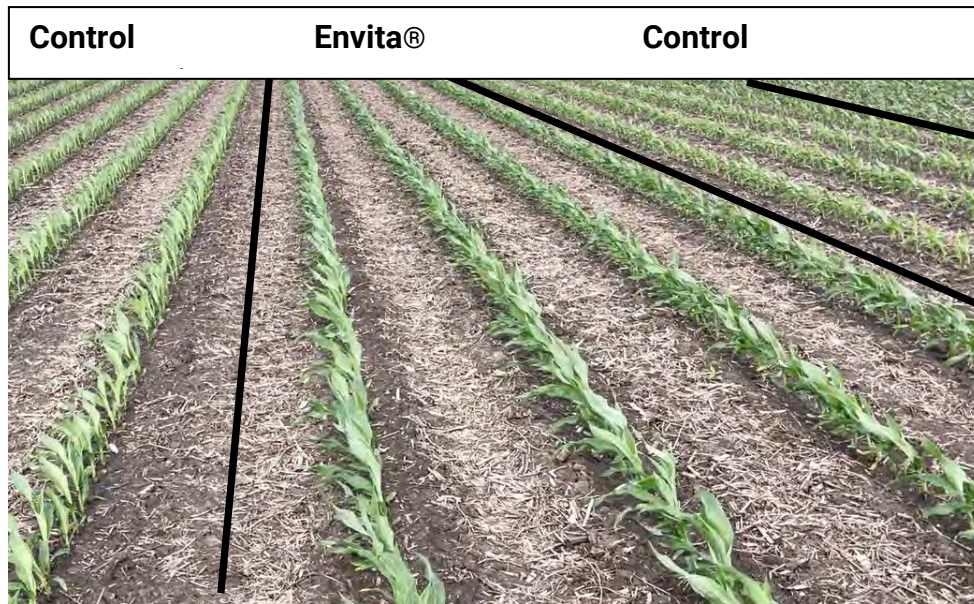

Planting Date: April 27th Hybrid: AgriGold® 639-70 Population: 36K Row Width: 30" Rotation: CAB Corn Price: \$6.00 Envita: \$14.95/A.

Source™ Foliar V4 Application Study

Objective: To evaluate the yield, economics, and nitrogen efficiency of Source™, a foliar-applied nutrient efficiency product that increases plant-available nitrogen and phosphorus to support healthier plants and improved productivity. Source™ contains 20.5% Maltol Lactone that activates nitrogen fixing bacteria, which turns atmospheric nitrogen into a plant available form.



Source™ is applied at a rate of 0.7 fl oz/A. at the V4 growth stage with 20 Gal/A. water carrier.

Due to its potential nitrogen efficiency, Source™ was applied in conjunction with 100% rates of N (180# N) as well as a -10%, -15%, and -20% reductions.

Results: Tables 1-2. illustrate applications of Source™ at V4 resulted in +3.0 Bu/A. yield gains with a positive return on investment of +\$5.50/A. when applied with normal 100% nitrogen rates. As nitrogen rates were decreased by 10% with Source™, yield was stable and +0.6 Bu/A. of the control. Economics in Table 2. illustrate a positive return on investment of +\$5.14/A.

However, as nitrogen rates were decreased to -15% and -20%, corn yield fell by **-5.7 to -10.9 Bu/A.** along with corresponding economic net losses of **-\$25.64 to -\$49.82/A.**

It should be noted that this trial is irrigated with yields at or near 280 Bu/A. Total nitrogen applied at 180# results in a nitrogen use efficiency (NUE) factor of just 0.64. With this efficient NEU rate, further reducing nitrogen by -10%, -15%, or -20% would not be recommended. As NUE rates climb to 1.0 over, it could become more prudent.

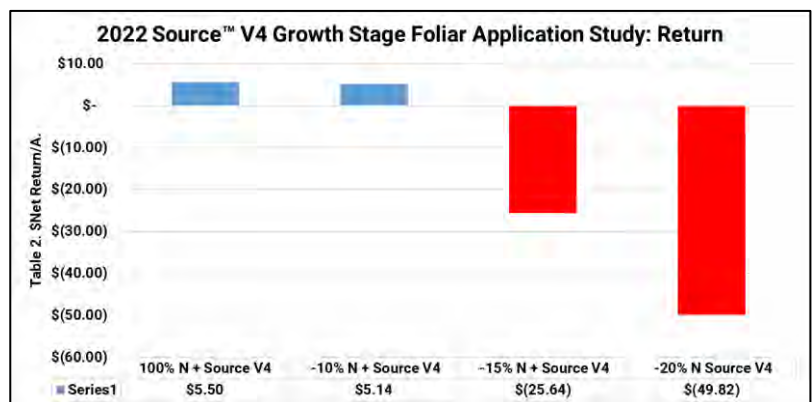
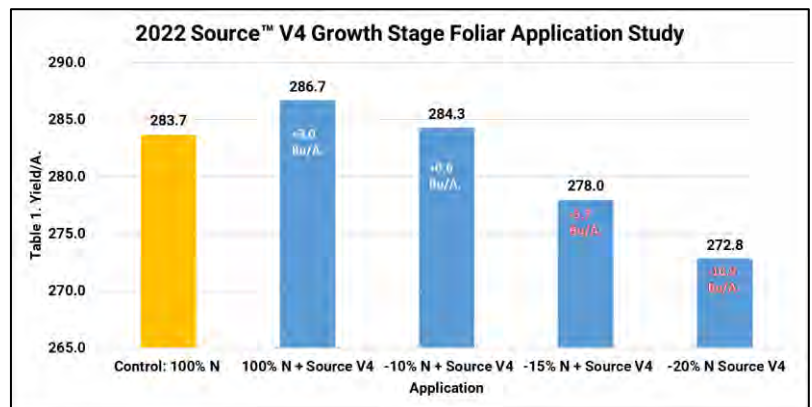

Source™ Foliar VT Application Study

Objective: To evaluate the yield, economics, and nitrogen efficiency of Source™, a foliar-applied nutrient efficiency product that increases plant-available nitrogen and phosphorus to support healthier plants and improved productivity. Source™ contains 20.5% Maltol Lactone that activates nitrogen fixing bacteria, which turns atmospheric nitrogen into a plant available form.



Source™ is applied at a rate of 0.7 fl oz/A. at the VT growth stage with 20 Gal/A. water carrier.

Due to its potential nitrogen efficiency, Source™ was applied in conjunction with 100% rates of N (180# N) as well as a -10%, -15%, and -20% reductions.

Results: Tables 1-2. illustrate applications of Source at V4 resulted in +3.5 Bu/A. yield gains with a positive return on investment of +\$8.50/A. when applied with normal 100% nitrogen rates. As nitrogen rates were decreased by 10% with Source™, yield fell by **-1.9 Bu/A.** of the control. Economics in Table 2. illustrate the result of a negative return on investment of **+\$9.86/A.**

As nitrogen rates were decreased to -15% to -20%, corn yield fell by **-4.2** to **-13.2 Bu/A.** along with corresponding economic net losses of **-\$16.64** to **-\$63.62/A.**

It should be noted that this trial is irrigated with yields at or near 280 Bu/A. Total nitrogen applied at 180# results in a nitrogen use efficiency (NUE) factor of just 0.64. With this efficient NEU rate, further reducing nitrogen by -10%, -15%, or -20% would not be recommended. As NEU rates climb to 1.0 over, it could become more prudent.

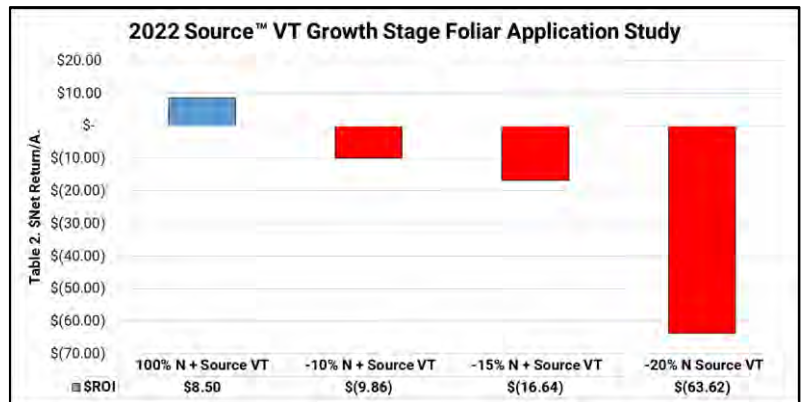
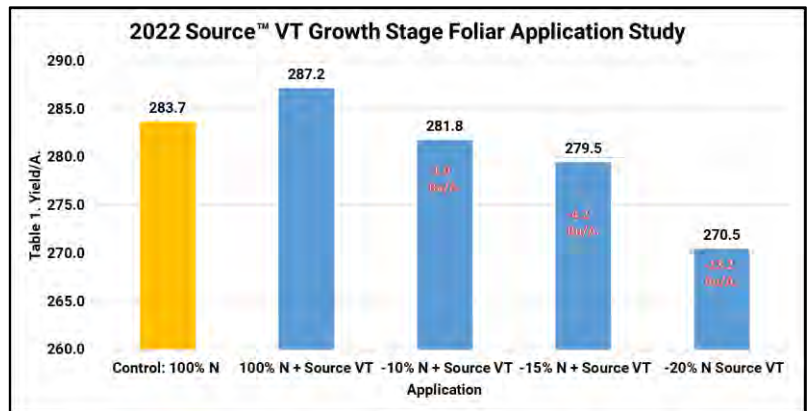

QLF L-CBF BOOST™ 4-0-3-2S Nitrogen Inclusion Study

Objective: To evaluate yield, net return, and nitrogen use efficiency (NUE) of QLF™ Agronomy’s Liquid Carbon-Based Fertilizer (L-CBF) BOOST 4-0-3-2S added to UAN 32% applied through a Conceal® dual band (Figure 1.) application system.

BOOST is a concentrated source of available carbon in a low pH chemistry package. Derived of a cane molasses-based product (30% sugar) with a fermentation yeast extract, BOOST also contains chemistry designed to stimulate biological activity and enhance nutrient cycling in soils. Since BOOST works symbiotically to directly support the health and productivity of the soil by feeding soil microbes and assisting with nutrient cycling, this study specifically evaluates the ability of BOOST to act as nitrogen inclusion additive to aid in NUE.

For this study, a 10% nitrogen inclusion rate is evaluated compared to 100% rates of nitrogen (N) with and without BOOST:

Control: 100% N: 25 Gal/A. 32% UAN At-Plant Dual Band Conceal® followed by 25 Gal/A. 32% UAN V4 Side-Dress

10% N Reduction: 20 Gal/A. 32% UAN At-Plant Dual Band Conceal® followed by 25 Gal V4 Side-Dress (5 Gal/A. reduction)

10%BOOST Inclusion: 20 Gal/A. 32% UAN + 2.5 Gal/A. BOOST™ At-Plant Dual Band Conceal® followed by 22.5 Gal 32% UAN + 2.5 Gal/A. BOOST V4 Side-Dress

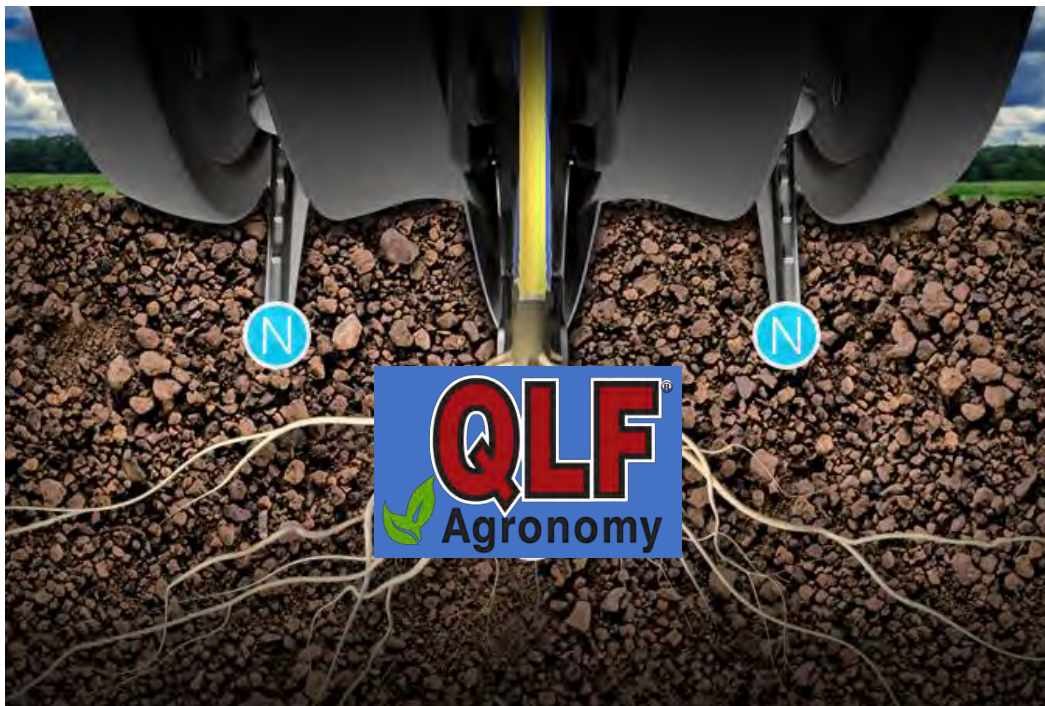
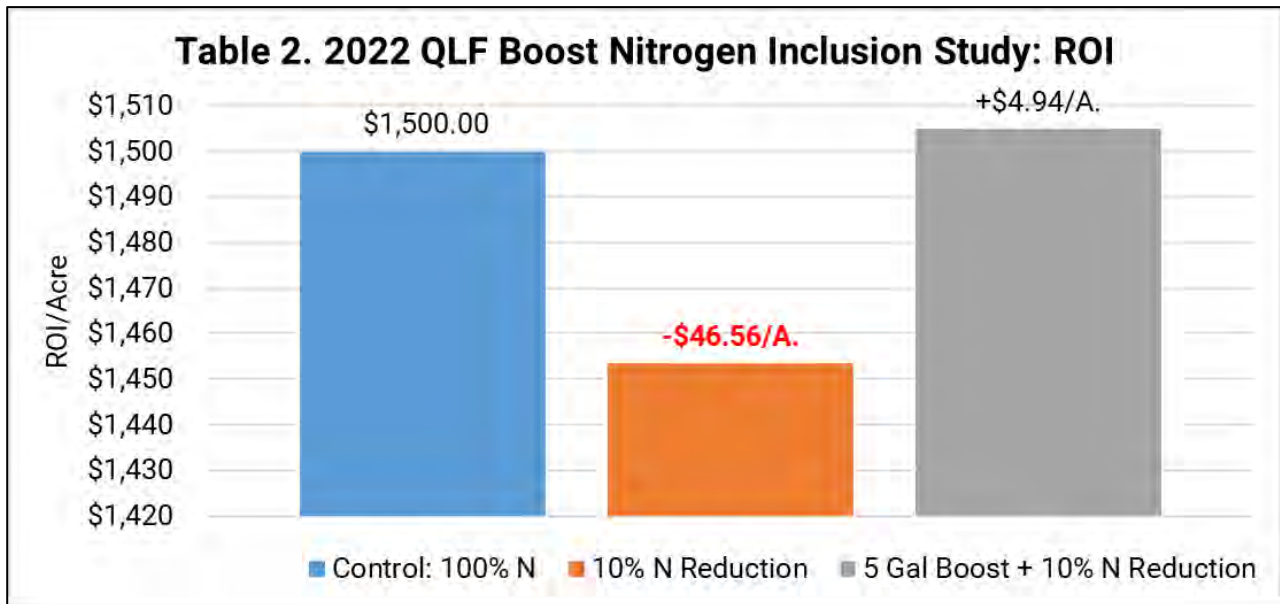
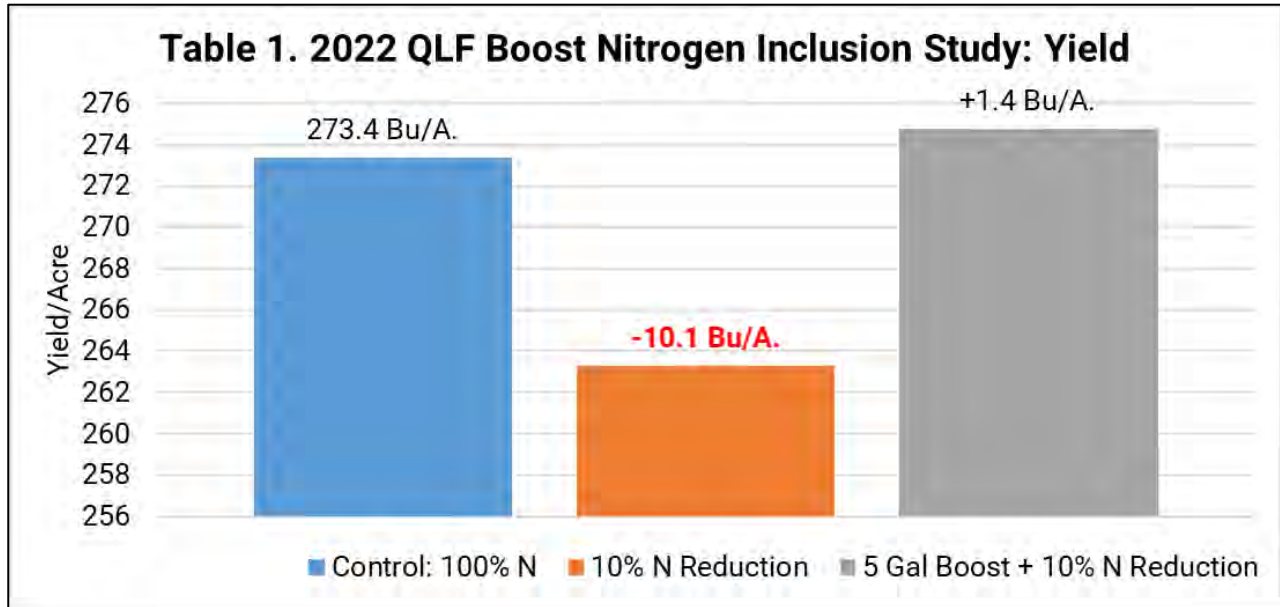

Figure 1. Conceal dual band nitrogen placement 3” away from seed furrow 1.5”

QLF™ L-CBF BOOST™ 4-0-3-2S Nitrogen Inclusion Study Continued

Results: Tables 1-2. illustrate reducing total nitrogen by 10% resulted in yield losses of **-10.1 Bu/A.** and net economic losses of **-\$46.56/A.** However, BOOST inclusion treatments increased corn yield by +1.4 Bu/A., while realizing a positive return on investment of +\$4.94/A.

This 2nd year study reflects efficiencies gained with the BOOST inclusion, ensuring a better recovery of UAN 32% investment delivered through the Conceal® dual band system.



Aqua-Yield® NanoCS® FurrowJet® Study

Objective: To evaluate yield and economics of NanoCS® by AQUA-YIELD. NanoCS® is a starter fertilizer enhancer with a robust combination of NanoShield® Technology, balanced NPK, Zinc, and Bio Stimulant. Aqua-Yield products contain nanoparticles that penetrate cell walls and creates a nano-sized shield around nutrient/molecules/ions. This technology delivers essential nutrients into the seed for rapid germination and growth.

Figure 1: FurrowJet® In-Furrow Application



This trial aims to establish the efficiency of Aqua-Yield's NanoCS® nano-liquid based fertility product in tandem with Nachurs imPulse 10-18-4 100% orthophosphate in-furrow starter fertilizer. Performance of a 50% rate reduction (3Gal/A.) of 10-18-4 is then compared to the 100% rate (6 Gal/A). NanoCS® was applied in-furrow at planting in a FurrowJet® center only application (Figure 1).

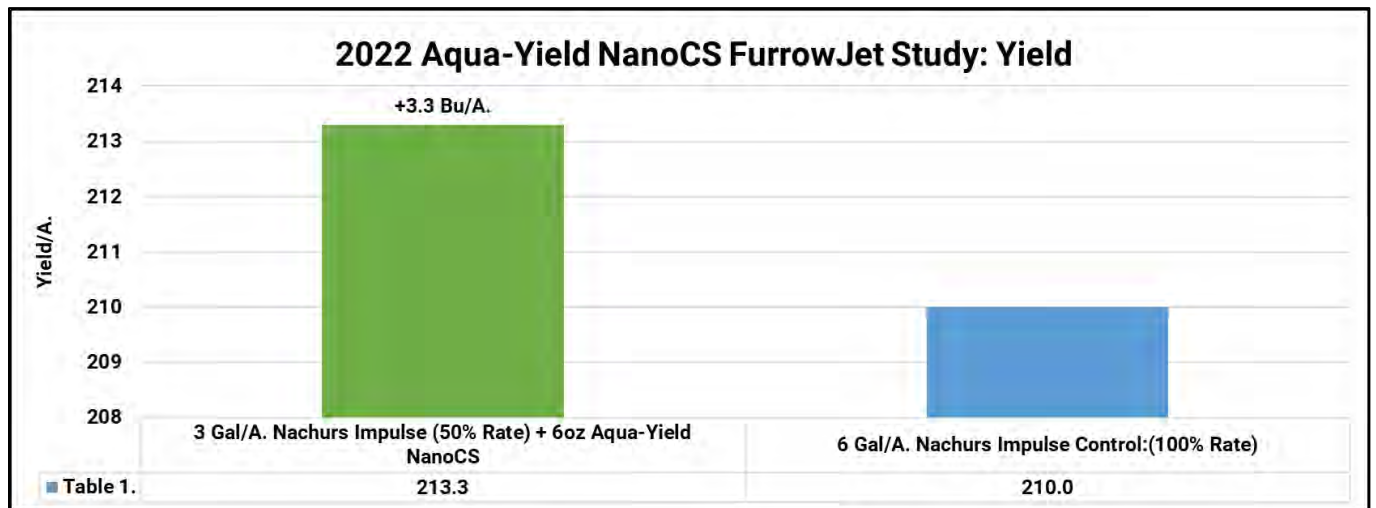

AQUA-YIELD®

NanoCS™

Aqua-Yield® NanoCS® FurrowJet® Study Continued

Results: Table 1. illustrates yield results of all treatments. The 100% rate control treatment at 6 Gal/A. of 10-18-4 resulted in yields of 251.4 Bu/A.

Aqua-Yield's NanoCS® tank-mixed with 50% 10-18-4 rates resulted in +3.3 Bu/A. yield improvement over and above the 100% rate control treatment.



Table 2. illustrates the overall economics of the fertility study. Reducing 10-18-4 in-furrow applications by 50% and tank-mixing NanoCS® resulted in economic gains of +\$29.20/A.

2022 was the PTI Farm's 2nd year testing NanoCS®. In 2021, NanoCS® resulted in +0.3 Bu/A. yield gains with corresponding net revenue gains of +\$6.87/A. when used in conjunction with a 10-18-4 in-furrow starter fertilizer.

As farmers, we are always interested in the ability to reduce fertilizer rates without sacrificing yield or profitability and we look forward to testing this product for a third year in 2023.

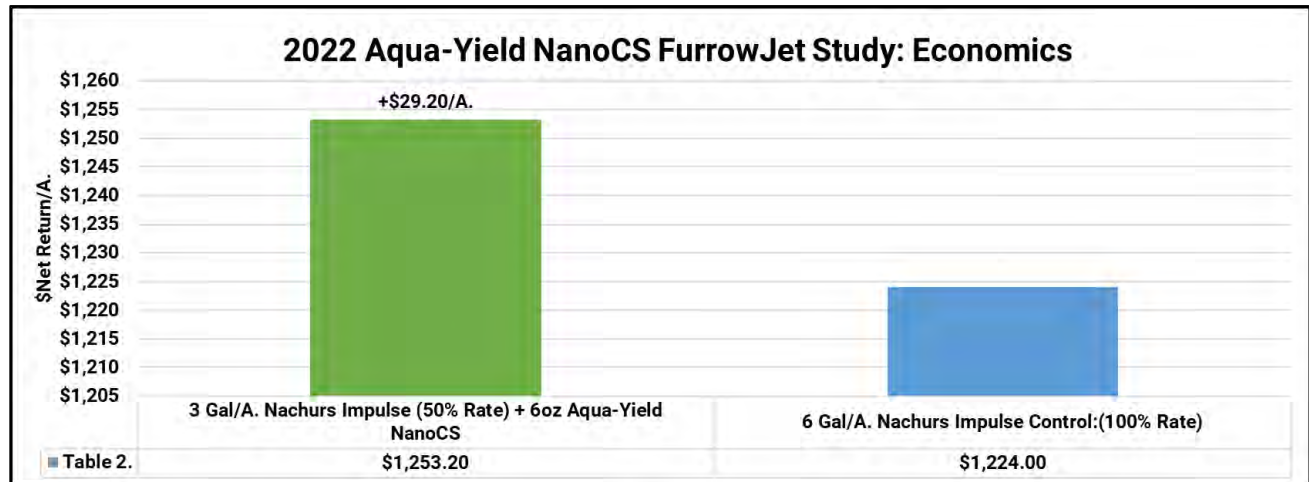

Aqua-Yield® CXPro FurrowJet® Biological Study

Objective: To evaluate yield and economics of CXPro by AQUA-YIELD. CXPro is a 100% plant-based extract used as an effective and flexible tool in building soil health and nutrient use efficiency throughout the growing season.

CXPro is a product manufactured with Purple Cow Organics® patented process where thousands of fungal and bacterial strains are driven to the soil and plant by Aqua-Yield Technology that shields exudates and metabolites, enhancing the rhizosphere.



Figure 1: FurrowJet® In-Furrow Application

This trial aims to establish the efficiency of Aqua-Yield’s CXPro nano-liquid based biological product applied at planting in a FurrowJet® center only application (Figure 1.) at a rate of 2.5 Gal/A.

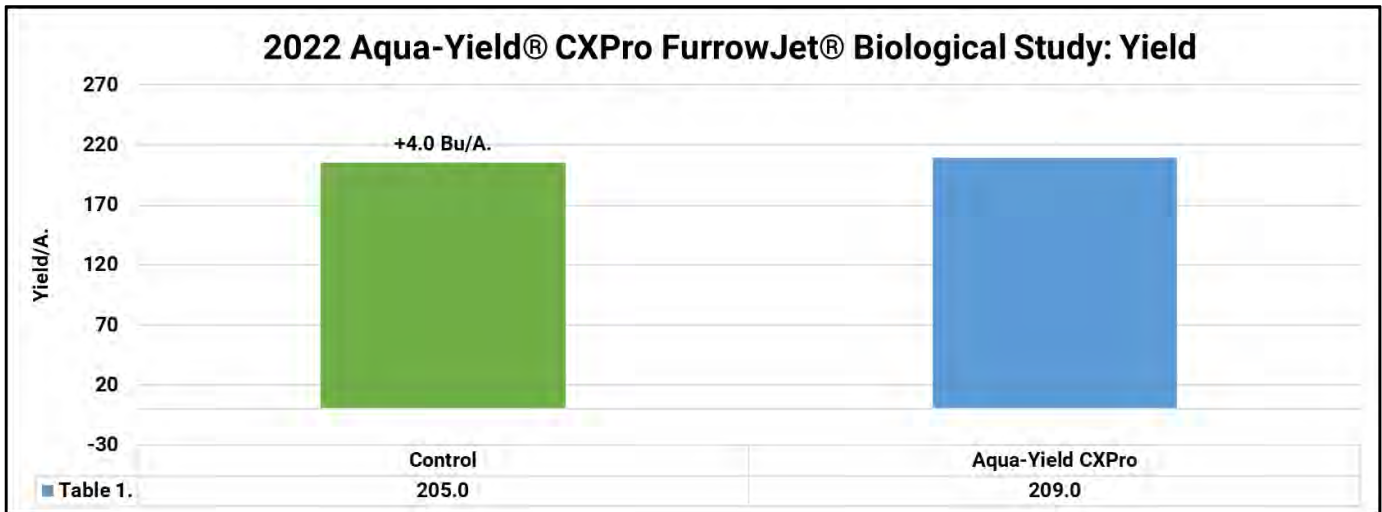

AQUA-YIELD®



Aqua-Yield® CXPro FurrowJet® Biological Study Continued

Results: Table 1. illustrates yield results of all treatments. Aqua-Yield’s CXPro resulted in +4.0 Bu/A. yield improvement over the control.

CXPro can be used in conjunction with most farm equipment that uses liquid. Mixing with other liquid fertility inputs and food sources such as molasses, sugars, humates, fish hydrolysate, kelps, and sea minerals is recommended. Purple Cow Organics Activator is the perfect companion product; a dry soluble humate and kelp formula to encourage the proliferation of naturally occurring soil microbes, with an emphasis on beneficial fungal development. CXPro can also be used with most products, or most microbially friendly fungicides and insecticides.



Table 2. illustrates the overall economics of the fertility study where CXPro resulted in positive economic gains of +\$1.25/A.

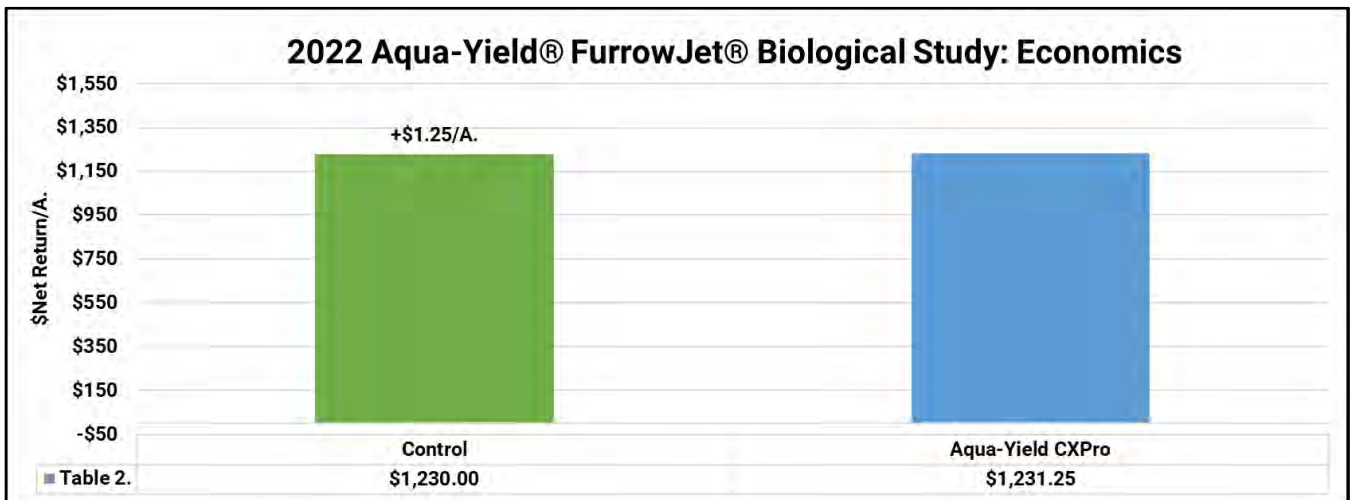

Planting Date: May 11th Hybrid: GH 15J91 Population: 36K Row Width: 30" Rotation: CAB Corn Price: \$6.00 CXPro: \$22.75/A.

AGROTECH NutriCharge® Phosphorus Efficiency Study

Objective: To evaluate the yield and economics of AgroTech’s NutriCharge®, a phosphorus efficiency product that when applied to phosphate (P) fertilizer, significantly increases single season P availability and plant uptake.

It has been theorized that 80% of P fertilizer applied to the soil is unavailable in a growing season. P fertilizer is mined from a mineral called apatite found in rock form within the soil, mostly calcium phosphate. Once mined, it’s processed into fertilizer

and upon application to the soil, the P fertilizer reacts quickly with cations in the soil (calcium, aluminum, and iron) going back into an unavailable form. NutriCharge® keeps your P available by preventing it from locking up in soil allowing the ability to double single season P availability.

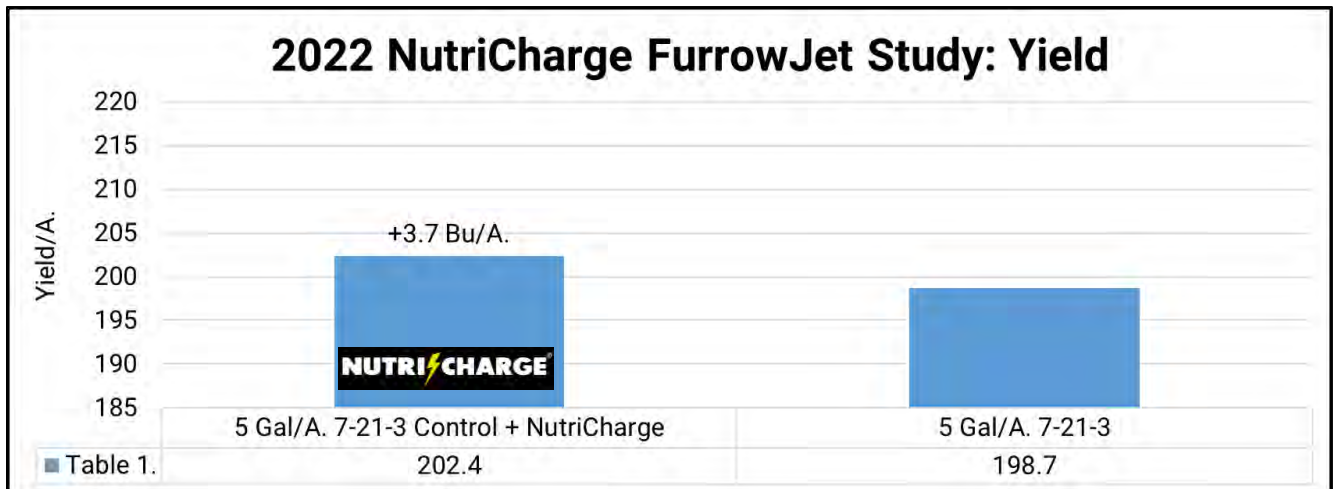

Figure 1. FurrowJet® 3-Way In-Furrow Tri-Band

This agronomic study focuses on NutriCharge® applied with and without a 5 Gal/A. rate of a liquid 6-20-4 at-plant starter fertilizer applied in a FurrowJet® 3-way in-furrow tri-band.

Results: In this second year PTI agronomic study, FurrowJet® applications of NutriCharge® resulted in yield gains of +3.7 Bu/A., as well as a positive return on investment of +\$17.82/A.

2021 data, our first year of testing NutriCharge®, resulted in yield gains of +3.4 Bu/A. with positive return on investment of \$12.62/A.



10-34-0 FurrowJet® Study

Objective: To evaluate the yield and net return of 10-34-0 liquid starter fertilizer. Seven different rates were used in a tri-band FurrowJet® system application at planting. 10-34-0 is a 70% polyphosphate formulation of nitrogen and phosphorus.

Results: 8 Gal/A. rates of 10-34-0 resulted in agronomic optimum rate, however economic optimum rate occurred at 6 Gal/A. with yield gains of +6.7 Bu/A. resulting in positive net returns of +\$37.49/A. As rates of 10-34-0 exceeded 8 Gal/A., yields were stagnant.

It is interesting to note that only two 10-34-0 rates (6 and 8 Gal/A.) achieved a return on investment of \$30 or more. At the PTI Farm we utilize a \$30 re-allocation program, where we reduce our fall dry fertilizer by \$30 to allow for the fertilizer being applied in the spring on the planter (in this case 10-34-0). If a re-allocation program was not implemented, 10-34-0 treatments with gains under \$30/A. would have resulted in net economic losses. This is particularly important since 10-34-0 incurred a +72.5% price increase for the 2022 season.

Figure 1: FurrowJet® 3-Way In-Furrow Band

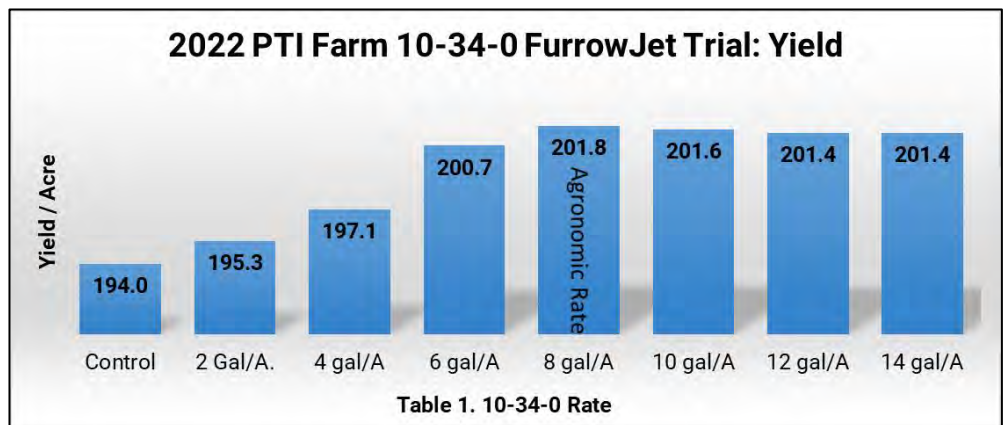

Phosphorus Placement Study

Objective: This study evaluates phosphorus placement efficiency when applied in and out of the furrow at planting. Phosphorus is immobile in the soil, meaning it does not move. Diffusion to the root has been studied to move only about 1/8 of an inch per year, which could lead to relatively small amounts of phosphorus in soil within that distance of a root. Thus, roots must grow through the soil to get the phosphorus the plant needs.

This study evaluates yield and economics of phosphorus placement efficiency when five and ten gallons of 10-34-0 is applied as an in-furrow FurrowJet® application, as well as dual band Conceal® applications 3" away from the seed trench.

The FurrowJet® system is a planter fertilizer attachment (Figure 1.) that enables placement of not only an in-furrow starter fertilizer, but also a dual-band of fertilizer 3/4" on each side of the seed.

The Conceal® system is a unique planter attachment that allows growers to place nutrients in a high concentration dual or single band positioned 3" away from the seed trench in depths near 1.5" (Figure 2).

Figure 1: FurrowJet® 3-Way In-Furrow Band

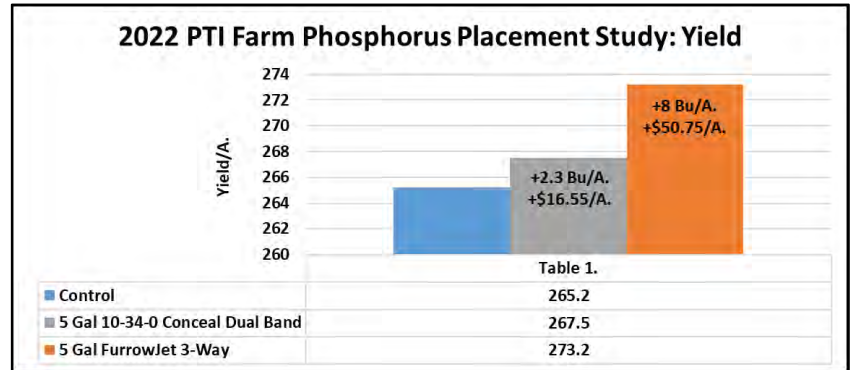

Figure 2. Dual Band Conceal Out of Furrow Bands



Phosphorus Placement Study Continued

Results: Table 1. illustrates yield advantage of 10-34-0 when applied at the lower 5 Gal/A. rates in this study. Conceal® applications resulted in gains of +2.3 Bu/A. with associated net returns of +\$16.55/A. FurrowJet® applications proved higher yield gains of +8.0 Bu/A. with net returns of +\$50.75/A. compared to the control.



However, the clear story here is the fact that in-furrow applications of Phosphorous out-yielded Conceal® “out of furrow” applications by nearly 3.5X. Regarding economics, placing Phosphorous out of furrow resulted in losses of **-\$34.20/A.**

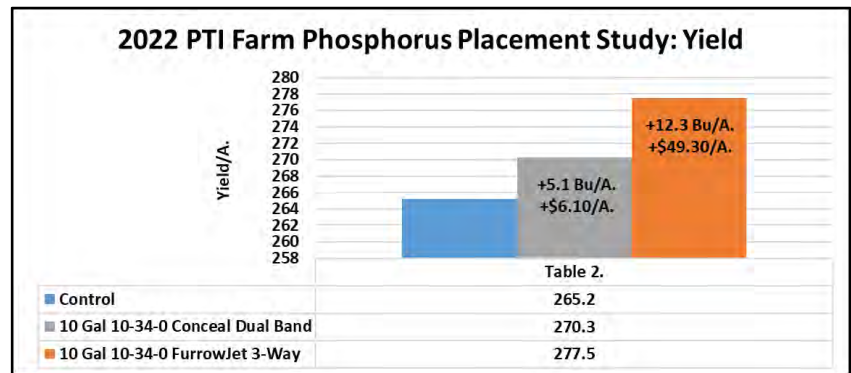
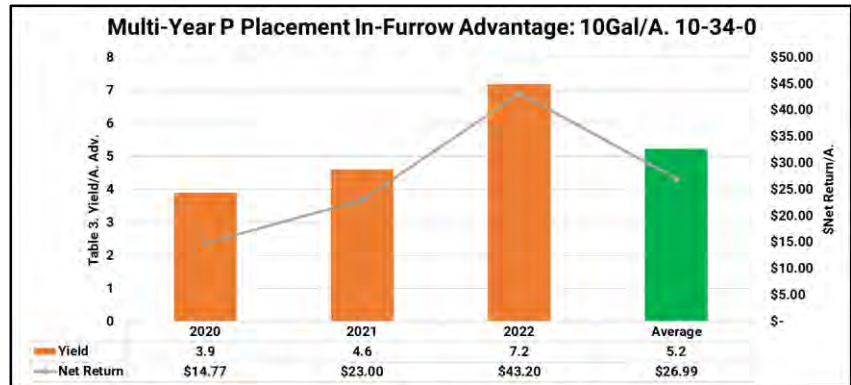

Table 2. illustrates yield advantages of 10-34-0 when applied at higher 10 Gal/A. rates. In this scenario, Conceal® applications resulted in gains of +5.1 Bu/A. with associated net returns of +\$6.10/A., while FurrowJet® applications proved higher yield gains of +12.3 Bu/A. with net returns of +\$49.30/A.



The trend continues from the 5 Gal/A. rates above, as in-furrow applications of Phosphorus out-yielded Conceal® “out of furrow” applications by nearly 2.4X.

Regarding economics, placing Phosphorus out of furrow compared to in-furrow, resulted in losses of **-\$43.20/A.**

In summary, since Phosphorus does not move in the soil, placement is critical to ensure quick and efficient plant uptake. Table 3. summarizes in-furrow applications of Phosphorus closer to the seed in-furrow have proven multi-year average yield gains of +5.2 Bu/A. with additional net revenue of +\$26.99/A. over the years of 2020 to 2022 at the PTI Farm.

QLF L-CBF 7-21-3 MKP FurrowJet® Study

Objective: To evaluate yield and net return of QLF™ Agronomy’s Liquid Carbon-Based Fertilizer (L-CBF) starter 7-21-3 MKP applied through a FurrowJet® in-furrow tri-band system (Figure 1.) at 3, 5 and 10 Gal/A. rates.

L-CBF 7-21-3 MKP is liquid starter blend derived from premium orthophosphate MKP (monopotassium phosphate) for plant available phosphorus, available carbon from sugar cane molasses as an energy source for soil microbes and enhanced biological function with an added fermentation yeast extract.

Figure 1. FurrowJet® Tri-band Application



Results: The tables below illustrate that the 5 Gal/A. rate provided yield gains of +6.5 Bu/A. with corresponding net returns of +\$40.00/A.*

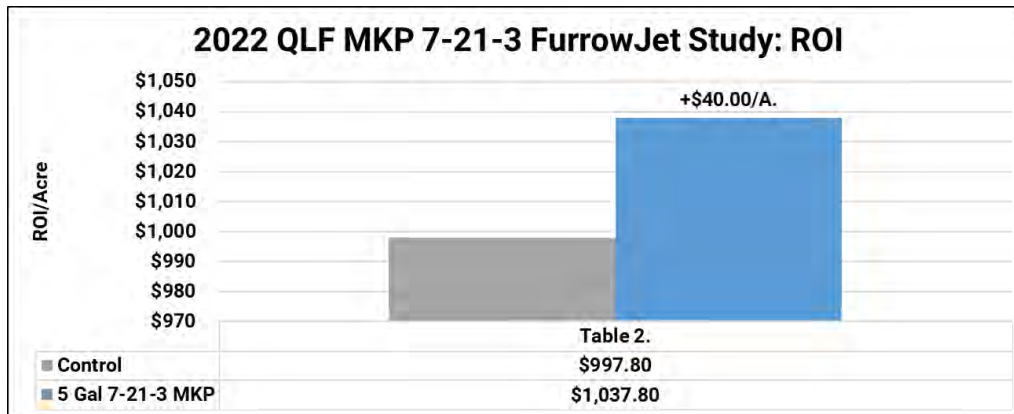
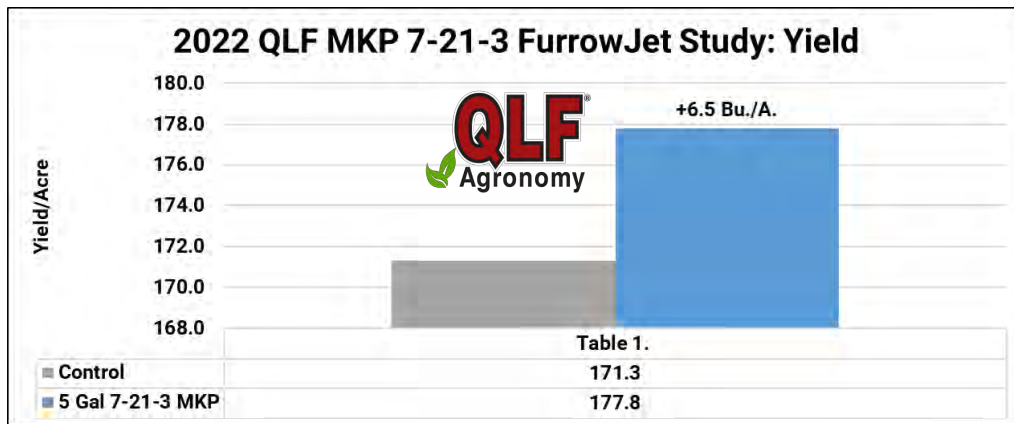

Stoller®USA FurrowJet® Study

Objective: This FurrowJet® system application trial evaluates the yield and net return of StollerUSA's Fortified Stimulate Yield Enhancer® Plus, Charge 12%™ and Harvest Plus™ applied in FurrowJet® tri-bands. (Figures 1-2.)

Fortified Stimulate Yield Enhancer® Plus is a plant growth regulator and EPA registered plant bio-stimulant that has four growth hormone ingredients that promotes plant growth. This product contains four key plant hormones including Cytokinin, Gibberellic acid, Indole-3-butyric acid, and Indole-3-acetic acid.

Charge 12%™ is an organic humic acid that improves nutrient utilization, root development, and soil aggregation. It is OMRI Listed for use in organic production.

Stoller's Harvest Plus™ is 8-0-0 premium liquid fertilizer that also contains 3% Sulfur, .25% Boron, 3% Manganese, and 3% Zinc.

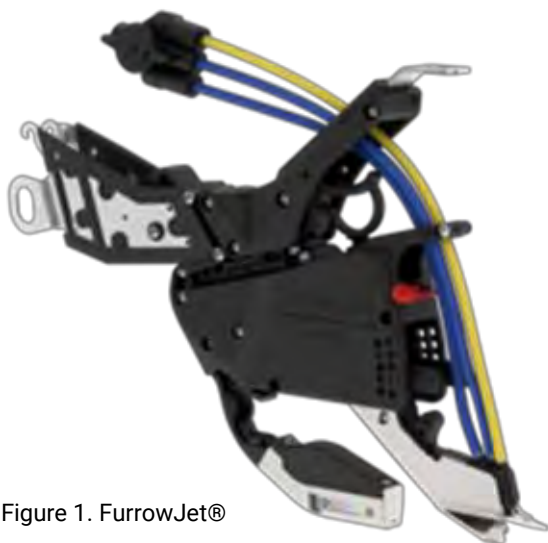

Figure 1. FurrowJet®

Fortified Stimulate® Yield Enhancer Plus

<p>ACTIVE INGREDIENTS:</p> <p>Cytokinin (as kinetin) 0.009%</p> <p>Gibberellic acid 0.005%</p> <p>Indole-3-butyric acid 0.005%</p> <p>Indole-3-acetic acid 0.005%</p> <p>OTHER INGREDIENTS:.....99.976%</p> <p>Total100.000%</p>	<p>CONTAINS NON-PLANT FOOD INGREDIENTS:</p> <p>0.009% Cytokinin</p> <p>0.005% Gibberellic Acid</p> <p>0.005% Indole-3-butyric Acid</p> <p>0.005% Indole-3-acetic Acid</p> <p><small>Information regarding the contents and levels of metals in this product is available on the internet at http://www.aaspfco.org/metals.html</small></p>
--	--

Charge 12%

CONTAINS NON-PLANT FOOD INGREDIENT(S):

GUARANTEED ANALYSIS:

Soil Amending/Active Ingredient(s):

Humic Acids (from Leonardite)12%

Total Other/Inert Ingredient(s): (aqueous solution).....88%

Harvest Plus

8-0-0

Enhanced Micro Blend

GUARANTEED ANALYSIS

Total Nitrogen (N).....8%

8% Ammoniacal Nitrogen (N)

Sulfur (S).....3%

3% Combined Sulfur (S)

Boron (B).....0.25%

Manganese (Mn).....3%

3% Chelated Manganese (Mn)

Zinc (Zn).....3%

3% Chelated Zinc (Zn)

Derived from aqueous ammonia, boric acid, manganese sulfate and zinc sulfate chelated with citric acid

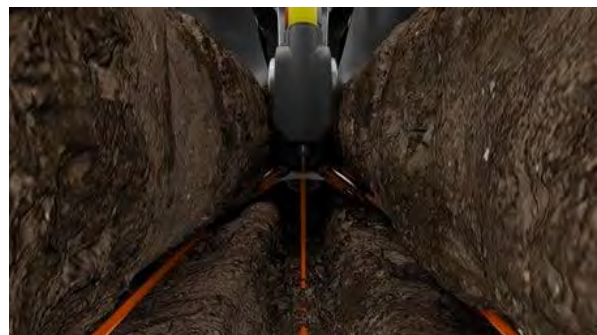

Stoller®USA FurrowJet® Study Continued

Results: Tables 1-2. illustrate Fortified Stimulate Yield Enhancer® plant growth regulator, Charge 12%™ and Harvest Plus™ combination offered yield gains of +7.3 Bu/A. applied in FurrowJet® tri- bands. This yield gains corresponded to positive net returns of +\$26.01/A.

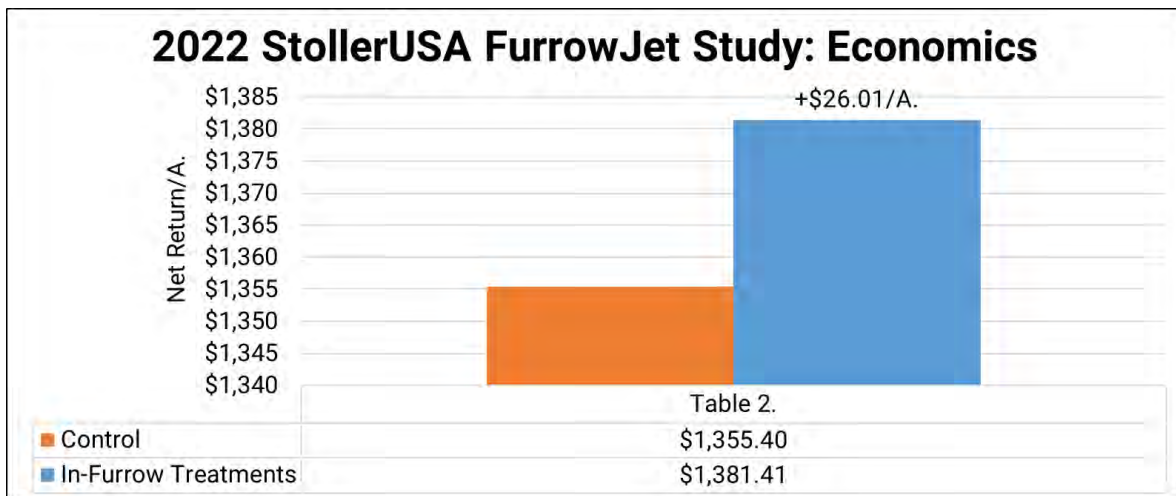
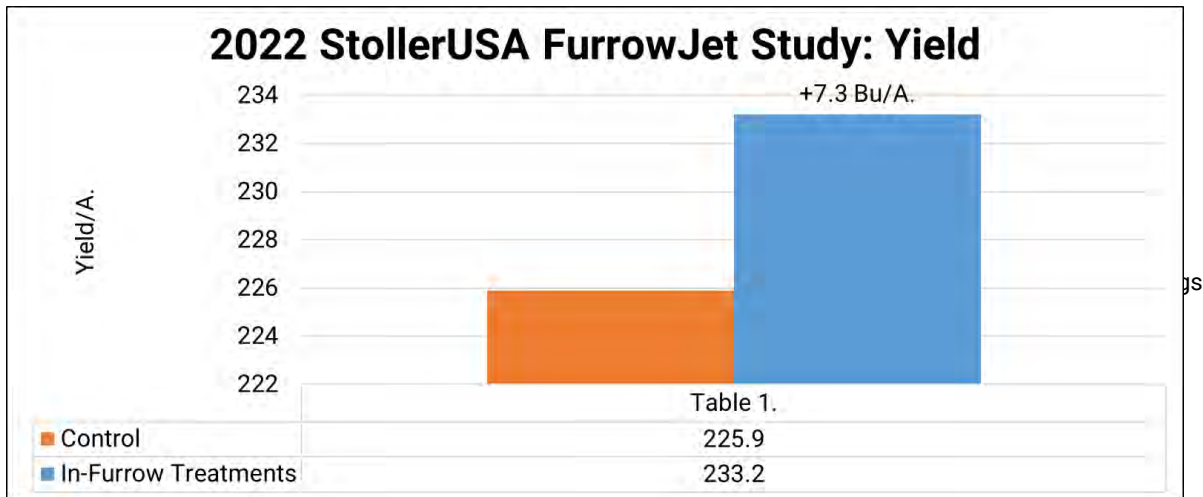

Planting Date: June 15th Hybrid: GH 02K93 Population: 36K Row Width: 30" Rotation: CAB Corn Price: \$6.00

Fortified Stimulate: \$6.26/A. Charge: \$5.32/A. Harvest Plus™: \$6.21/A.

Ethos® XB FurrowJet® Study

Objective: This FurrowJet® system (Figure 2.) trial evaluates the yield and net return of Ethos XB, an insecticide/fungicide that combines the active ingredient of Capture® LFR® insecticide with a broad-spectrum bio-fungicide. This combination defends against insect pest such as corn rootworms, wireworms, grubs, seed corn maggots, cutworms, and common stalk borers. This also defends against diseases such as Fusarium, Pythium, Rhizoctonia and Phytophthora.

The bio-fungicide in Ethos XB insecticide/fungicide forms a protective barrier on root surfaces and builds over time as spores germinate and colonize roots and root hairs.

Results: Ethos XB treatments applied through FurrowJet® system offered positive yield gains of +7.3 Bu/A. (Table 1.) Five years of testing (2018-2022) has realized average yield gains of +8.0 Bu/A. along with an average return on investment of \$13.23/A. (Table 2.)

Figure 1.

ACTIVE INGREDIENTS:	By Wt.
Bifenthrin *	15.67%
<i>Bacillus amyloliquefaciens</i> strain D747 **	5.00%
Other Ingredients.....	79.33%
Total:	100.00%

*Cis isomers 97% minimum, trans isomers 3% maximum
 ** Contains a minimum of 1x 10¹⁰ colony-forming units (cfu) per milliliter of product.
 This product contains 1.5 lbs bifenthrin per gallon.

Figure 2.

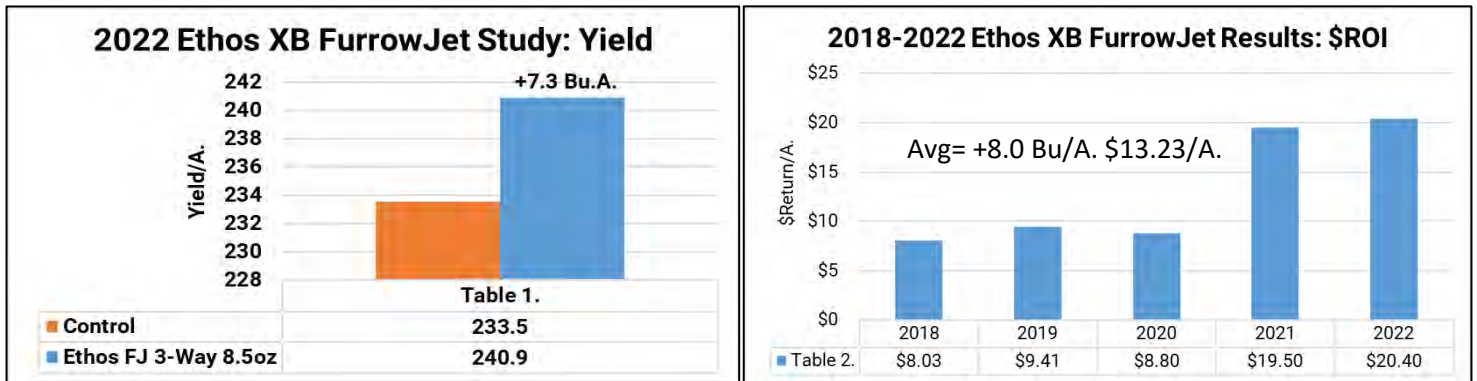
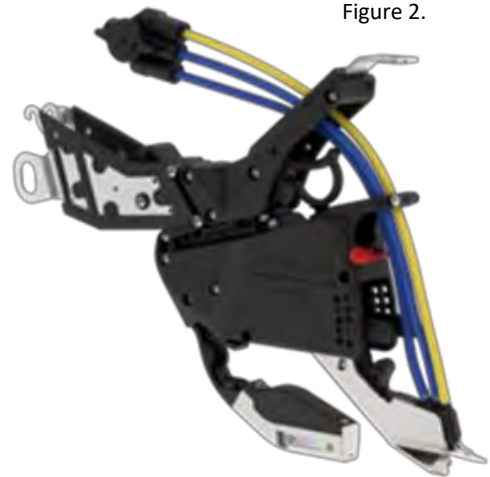

Xyway® LFR® FurrowJet® Study

Objective: To evaluate the yield and economic return of Xyway® LFR®, a fungicide with the active ingredient Flutriafol (Figure 1). Xyway® LFR® fungicide is promoted as a revolutionary at-plant fungicide formulation that provides season-long disease protection from the inside out, root to tassel and stalk to leaf.



Figure 1.

EPA Reg. No. 279-9638	EPA Est. No. 279-DE-001
Active Ingredient:	By Wt.
Flutriafol	26.4%
Other Ingredients:	73.6%
TOTAL:	100.0%

Contains 2.5 pounds per gallon of the active ingredient flutriafol. Suspension Concentrate.

This study evaluates Xyway® LFR® applied in various soil applied situations. First, Xyway® LFR® is evaluated as a in-furrow treatment applied through FurrowJet®, a planter fertilizer attachment that enables placement of fertilizer on the seed as well as 3/4" on each side of the seed (Figure 2-5). To achieve this dual-band placement, the wings on FurrowJet® system angle downward to cut into the sidewall and place fertilizer alongside the seed in a dual-band. By doing this, lifting and fracturing can occur that potentially could remove soil smearing or compaction created by disc openers.

In this study, Xyway® LFR® is evaluated in three different FurrowJet® placements consisting of:

FurrowJet® Center only (Figure 3.)

FurrowJet® Wings only (Figure 4.)

FurrowJet® 3-Way (Figure 5.)



Figure 2. FurrowJet® In-Furrow Planter Attachment

Figure 3. FurrowJet® Center Only



Figure 4. FurrowJet® Wings Only



Figure 5. FurrowJet® 3-Way: Center and Wings



Xyway® LFR® FurrowJet® Study Continued

Secondly, to focus on applications of Xyway® LFR® further away from the seed, a fourth treatment was also evaluated with Conceal®. A Conceal® system is a unique planter attachment that allows growers to place product in a high concentration dual or single band positioned 3" away from the seed trench (Figure 7.) in depths near 1.5". The Conceal® system uses existing planter space, utilizing a backswept knife located with-in the center of the planter's gauge wheels (Figure 6). As product is applied, it is sealed within the soil profile by the

Figure 6. Conceal Knife Design within Gauge Wheel



Figure 7. Conceal Dual Placement 3" from Seed Trench gauge wheels.

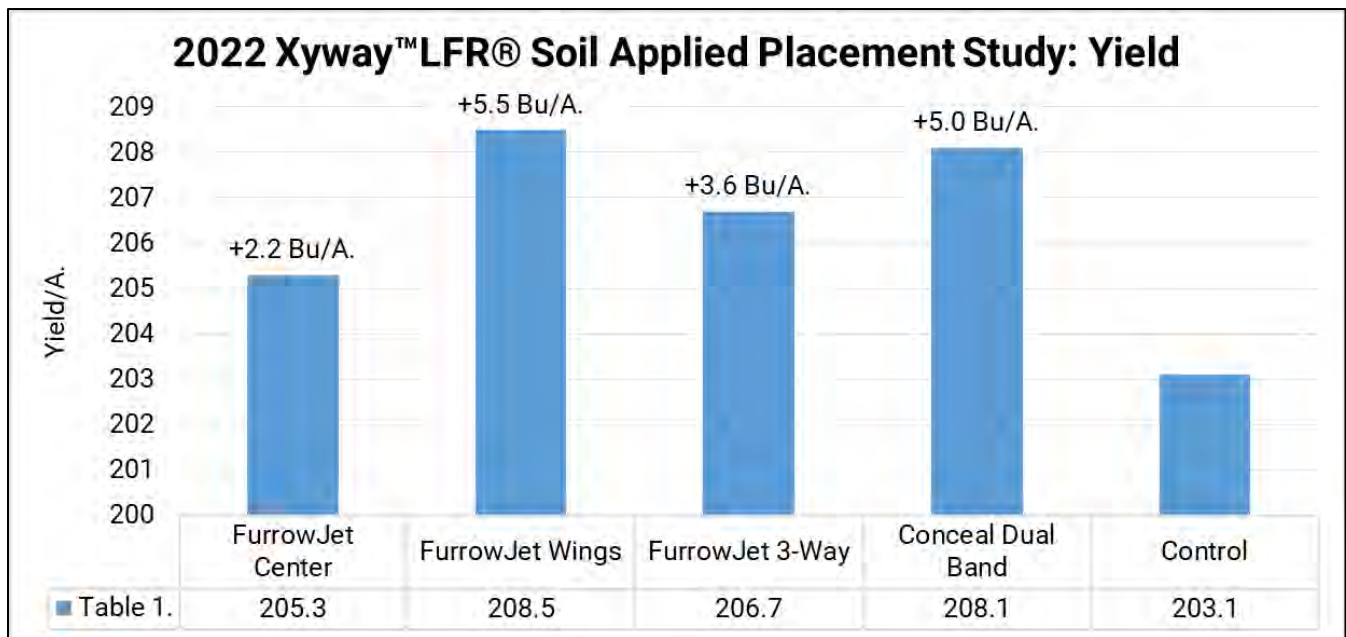

Xyway® LFR® FurrowJet® Study Continued

Results: Table 1. illustrates all treatments did in fact result in positive yield gains. However, Xyway® LFR® placed closest to the seed in-furrow resulted in the lowest yield gains in the study. As flutriafol treatments were placed closest to the seed via FurrowJet® center applications, yield gain was still realized, but only at +2.2 Bu/A. FurrowJet® 3-way applications, having 1/3rd of its application in the center, offered the 2nd lowest yield gain in the study at +3.6 Bu/A. Both these treatments resulted in an overall return on investment of **-\$6.80/A.** and +\$1.60/A. respectively (Table 2).

As flutriafol was placed outside of the seed trench, FurrowJet® wings offered the trial's highest yield gains at +5.5 Bu/A. and Conceal® placements resulted in gains of +5.0 Bu/A. These treatments resulted in an overall return on investment of +\$12.40/A. and \$10.00/A.

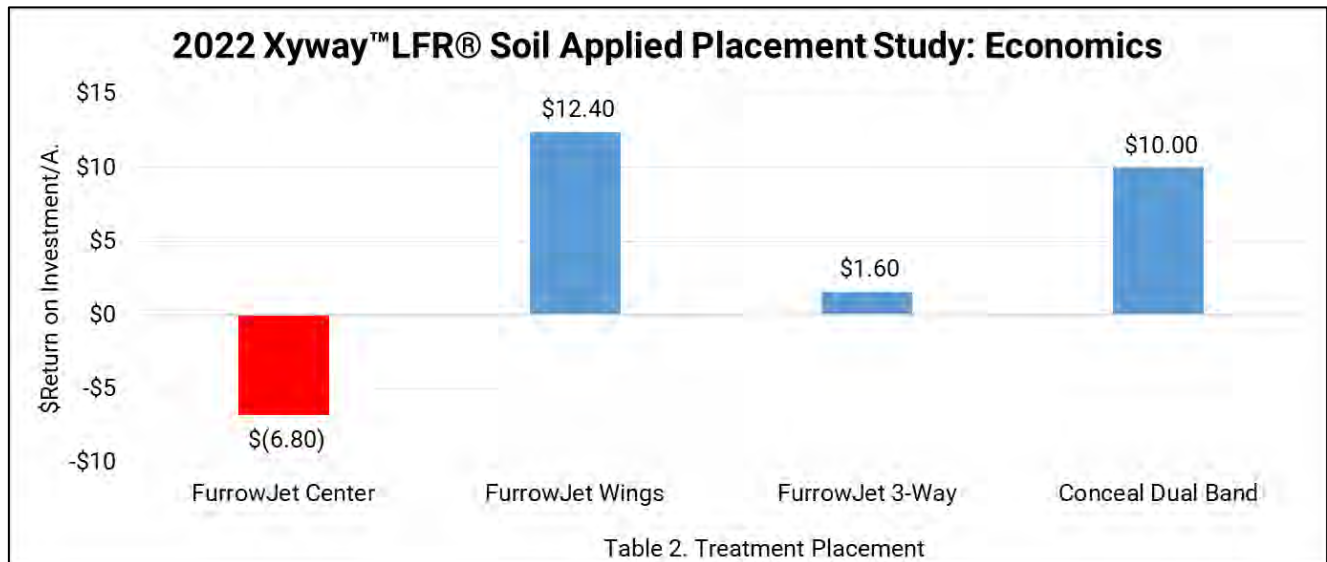

Kelpak® Bio Stimulant FurrowJet® Corn Study

Objective: To evaluate yield and net return of Kelpak® formulations as an in-furrow Bio Stimulant application. To compare the different Bio Stimulant components including treatments of Kelpak® and Kelpak® Pro.

Kelpak® is an effective liquid seaweed concentrate made from the fast-growing giant kelp, *Ecklonia maxima*. (Figure 1.) Kelpak® is manufactured from the kelp species *Ecklonia maxima*, which grows only in the clean, cold waters off the Atlantic Coast of southern Africa. The nutrient rich Benguela Current and powerful tidal action provide perfect conditions for the rapid growth of these giant kelp forests.



Figure 1. *Ecklonia maxima*

Kelpak® Bio Stimulant FurrowJet® Corn Study

Results: Kelpak® Pro treatments resulted in yield losses of **-4.3 Bu/A.**, which corresponded to economic losses of **-\$35.80/A.** However, Kelpak® DS offered yield gains of +2.37 Bu/A. and economic gains of +\$4.72/A.



TerraMax MicroAZ-IF™ FurrowJet® Corn Inoculant Study

Objective: To evaluate the use of MicroAZ-IF™, an in-furrow inoculant for corn that contains the stabilized bacteria Azospirillum. For this study, MicroAZ-IF™ is applied as a FurrowJet® center only application (Figure 1).



Figure 1. FurrowJet® Center Only



Results: MicroAZ-IF™ FurrowJet® treatments resulted in average yield gains of +3.2 Bu/A. At a \$6 corn commodity price and a product cost of \$8.93/A., MicroAZ-IF™ offered economic gains of \$9.67/A.

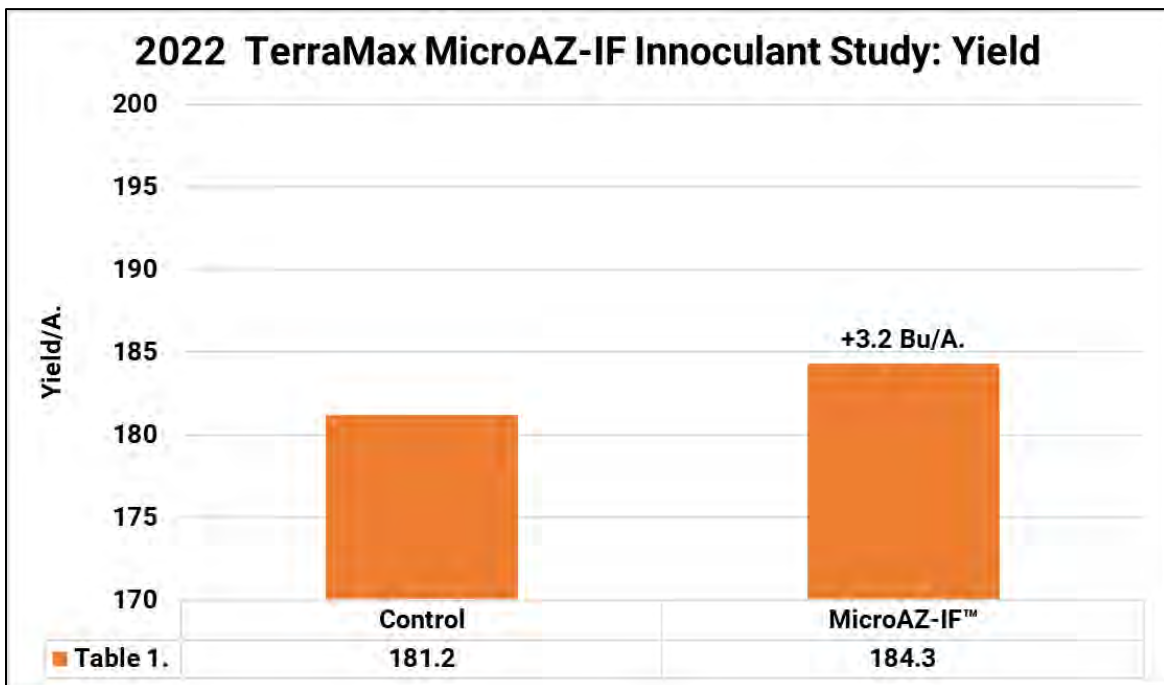

FurrowJet® Side-Wall Study

Objective: FurrowJet® is a planter fertilizer attachment (Figure 1.) that enables placement of not only an in-furrow starter fertilizer, but also a dual-band of fertilizer 3/4" on each side of the seed (Figure 2). To achieve this dual-band placement, the wings on FurrowJet® system angle downward to cut into the sidewall and place fertilizer alongside the seed in a dual-band. By doing this, lifting and fracturing can occur that potentially could remove soil smearing or compaction created by disc openers. (Figure 3.) Additionally, closing wheel systems following FurrowJet® wings have a better opportunity to close the seed trench, remove air pockets, and allow for good seed-to-soil contact.

This study evaluates FurrowJet® dual-band wings offering the ability to cut, lift and remove side-wall compaction in the seed furrow. For this study, no liquid fertilizer was applied.

Results: Table 1. illustrates the side-wall fracture advantages of FurrowJet® system in the 2018 to 2022 growing seasons. While 2018 offered +6.6 Bu/A. advantages, 2019 to 2022 all have proved significantly less at only +2.5, +2.6, +3.5 and +3.1 Bu/A. respectively. As mentioned in the objective, FurrowJet® systems do have the ability to assist in closing the furrow due to easier side-wall collapse. In 2019 -2022 our plot planter was fitted with a FurrowForce® system, a new robust automatic sensing and control closing wheel system. It is our belief that this system closed the gap on FurrowJet® system advantages due to superior closing activity. For growers using traditional single stage closing systems, FurrowJet® response could be more typical to 2018's yield response.

Figure 1. FurrowJet®

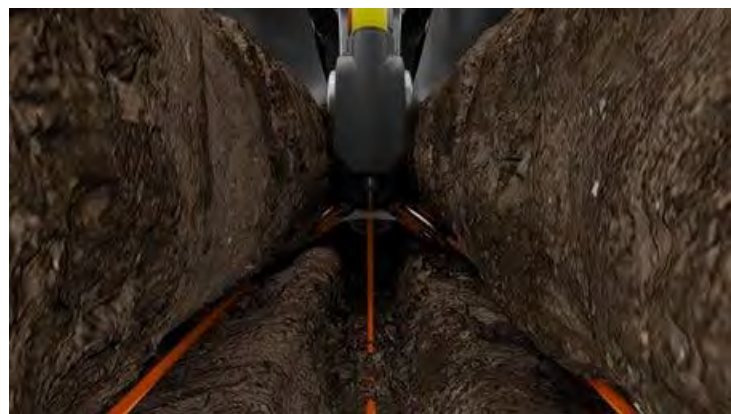

Figure 2: FurrowJet® Dual-Band Wings Fracturing Sidewalls



Corn Summary of 2022 FurrowJet® Applications

Study	Classification	Yield (Bu/A.)	\$ROI	Page #
Marco/QLF Corn High Management Nutritional Study FJ Wings	Carbon Based Sugar, Starter Fertilizer	8.7	\$ 52.92	77-79
Phosphorus Placement - FJ 3 Way 5Gal 10-34-0	Starter Fertilizer	8	\$ 50.75	100-101
Marco QuickGrow LTE 6Gal	Starter Fertilizer	8.5	\$ 50.40	83
Phosphorus Placement - FJ 3 Way 10Gal 10-34-1	Starter Fertilizer	12.3	\$ 49.30	100-101
Marco QuickGrow LTE 4Gal	Starter Fertilizer	6.4	\$ 48.00	83
Nachurs imPulse FJC 6Gal	Starter Fertilizer	9	\$ 48.00	84
Marco/QLF Corn High Management Nutritional Study Conceal & FJ Combo	Carbon Based Sugar, Starter Fertilizer	22.2	\$ 44.26	77-79
Nachurs imPulse FJC 5Gal	Starter Fertilizer	6.8	\$ 40.80	84
QLF 7-21-3 5Gal	Starter Fertilizer	6.5	\$ 40.00	102
Marco QuickGrow LTE 8Gal	Starter Fertilizer	8.4	\$ 39.60	83
Envita 100% N	Biological + Nitrogen	8.7	\$ 37.50	89-90
10-34-0: 6Gal	Starter Fertilizer	6.7	\$ 37.49	99
Nachurs imPulse FJC 4Gal	Starter Fertilizer	5.0	\$ 36.00	84
Marco/QLF Corn High Management Nutritional Study FJ Center	Carbon Based Sugar, Starter Fertilizer	3.8	\$ 34.79	77-79
Nachurs imPulse FJC 7Gal	Starter Fertilizer	7.7	\$ 34.20	84
10-34-0: 8Gal	Starter Fertilizer	7.8	\$ 33.18	99
Nachurs Start to Finish	Starter Fertilizer	9.5	\$ 31.44	85
Aqua Yield NanoCS	Starter Fertilizer Enhancer	3.3	\$ 29.20	94-95
10-34-0: 2Gal	Starter Fertilizer	1.3	\$ 26.90	99
10-34-0: 4Gal	Starter Fertilizer	3.1	\$ 26.79	99
StollerUSA FurrowJet Program	PGR, Humic Acid, Starter Fertilizer	7.3	\$ 26.01	103-104
10-34-0: 10Gal	Starter Fertilizer	7.6	\$ 21.08	99
EthosXB	Insecticide + Fungicide	7.3	\$ 20.40	105
FurrowJet SideWall Study	Mechanical	3.1	\$ 18.60	112
Agrotech NutriCharge	Phosphorus Efficiency	3.7	\$ 17.82	98
Pivot Bio ProveN40: 25% N Reduction + ProveN40	Biological + Nitrogen	0.4	\$ 16.50	86-87
Xyway LFR FJ Wings	Fungicide	5.5	\$ 12.40	106-108
TerraMax Micro AZ-IF	Inoculant	3.2	\$ 9.67	111
Ocean Blue Corn 80oz Nutrishield in Furrow + 6 Gal Power Pro Conceal	Calcium, Sea Salt, Starter Fertilizer	5.6	\$ 9.56	80-82
10-34-0: 12Gal	Starter Fertilizer	7.4	\$ 8.98	99
May 11th Corn Planting Date with Starter	Starter Fertilizer	12.1	\$ 8.20	8-9
May 2nd Corn Planting Date with Starter	Starter Fertilizer	12.0	\$ 7.60	8-9
April 26th Corn Planting Date with Starter	Starter Fertilizer	11.8	\$ 6.40	8-9
Kelpak Double Strength 1pt	Starter Fertilizer	2.37	\$ 4.72	109-110
Xyway LFR FJ 3Way	Fungicide	3.6	\$ 1.60	106-108
Aqua-Yield CXPro	Plant Based Extract	4.0	\$ 1.25	96-97
May 20th Corn Planting Date with Starter	Starter Fertilizer	10.9	\$ 1.00	8-9
10-34-0: 14Gal	Starter Fertilizer	7.4	\$ (1.93)	99
June 6th Corn Planting Date with Starter	Starter Fertilizer	7.6	\$ (18.80)	8-9
Kelpak Pro 2pt	Seaweed Concentrate	-4.3	\$ (35.80)	109-110
Average		6.8	\$ 23.17	



Single Application Pre-Emerge Nitrogen Study: Conceal® vs. Weed-N-Feed 100%

Objective: To compare 100% single applications of surface applied broadcast Weed-N-Feed (WNF) 32% UAN treatments to Conceal® system single and dual band at-plant nitrogen applications. Conceal® system is a unique planter attachment that allows growers to place nitrogen in a high concentration dual or single band positioned 3" away from the seed trench in depths near 1.5" (Figure 2). The Conceal® system uses existing planter space, utilizing a backswept knife located with-in the center of the planter's gauge wheels (Figure 1). As nitrogen is applied, it is sealed within the soil profile by the gauge wheels, preventing potential volatilization losses that is typically problematic with surface type nitrogen applications.

Results: Table 1. illustrates that Conceal® system dual band applications of nitrogen out-yielded traditional 100% WNF by +10.2 Bu/A., while Conceal® system single band treatments out-performed the same by +4.6 Bu/A.

In summary, planter applied nitrogen equated to additional revenue gains over WNF applications by +\$27.60/A. and +\$61.20/A.

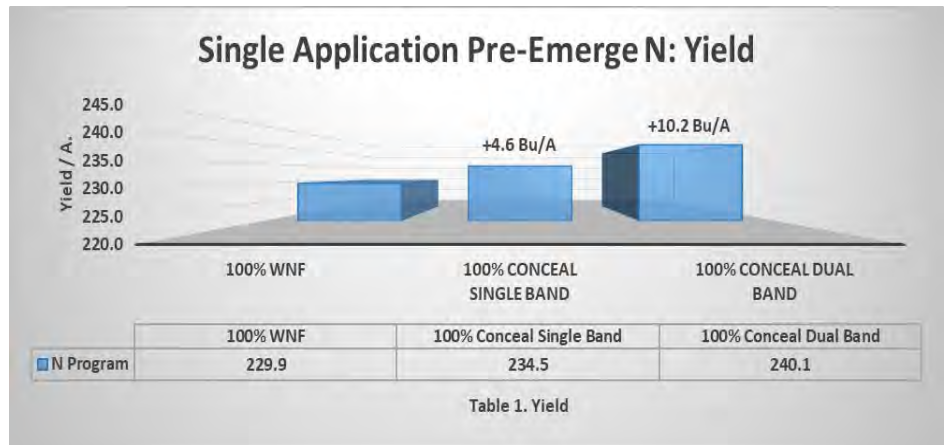

Figure 1. Conceal System Knife Design within Gauge Wheel



Figure 2. Conceal Dual Placement 3" from Seed Trench



Single Band vs. Dual Band Conceal® Nitrogen Study

Objective: To compare dual band versus single band applications of nitrogen in an at-plant scenario using Conceal®. Both treatments consist of 100% of 180lbs total nitrogen at planting, all using UAN 32%.

A Conceal® system is a unique planter attachment that allows growers to place nitrogen in a high concentration dual or single band positioned 3" away from the seed trench (Figure 1.) in depths near 1.5". If corn is planted at a 2" depth, Conceal® system fertilizer placement is 3X-0.5X1 in single bands and 3X-0.5X2 in dual bands.

Conceal® uses existing planter space, utilizing a backswept knife located within the center of the planter's gauge wheels (Figure 1). As nitrogen is applied, it is sealed within the soil profile, preventing potential volatilization losses typically seen with surface type nitrogen applications.

Figure 1. Conceal Single or Dual Placement 3" from Seed Trench, 1.5" in Depth



Results: Table 1. illustrates that dual band applications of nitrogen out-yielded single band applications by +5.6 Bu/A. These yield gains consequently equated to additional net returns of +\$33.60/A. (Table 2).

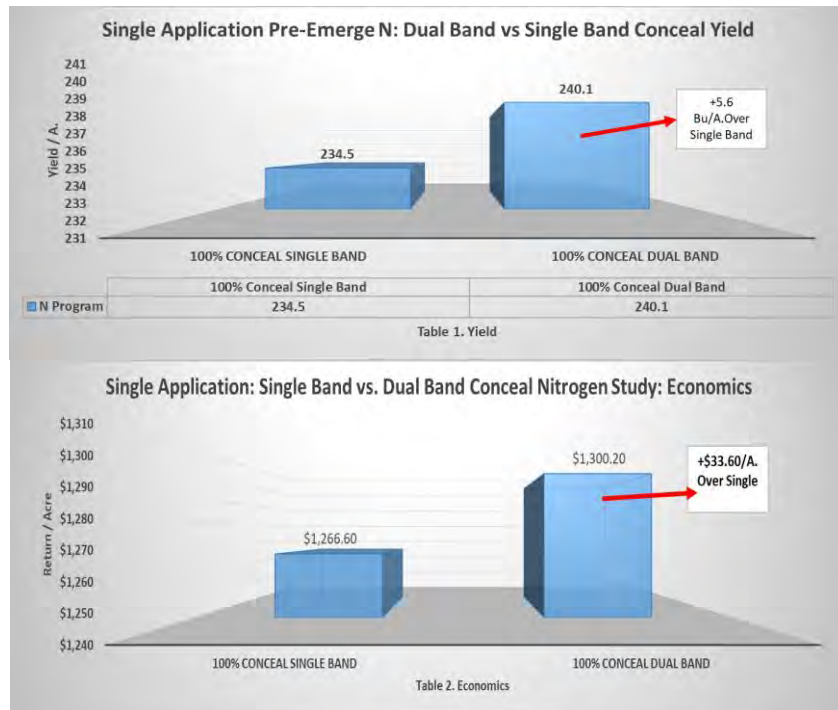

Planting Date: 5/2

Hybrid: GH 10D21

Population: 36K

Row Width: 30"

Rotation: CAC

Corn Price: \$6.00

At-Plant Nitrogen Placement Study

Objective: To evaluate and compare yield and economic impact of at-plant applications of 20 Gal/A. of liquid 32% UAN nitrogen placed in four different systems including the following:

Dribble Tubes: Figure 1.

Surface applies nitrogen behind gauge wheels and 3" to side of center of furrow.



Figure 1.



John Deere® 2X2: Figure 2.

Uses coulters/knife ahead of row unit to inject fertilizer 2" below and 2" over from seed



Figure 2.

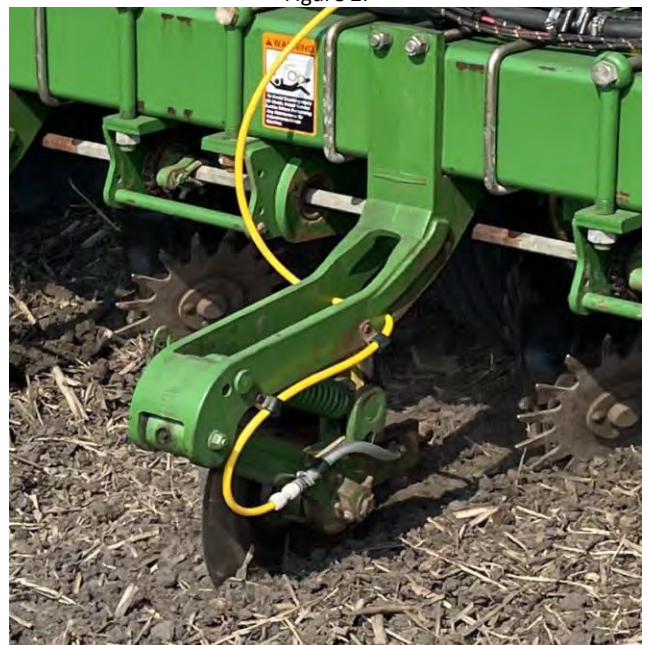

At-Plant Nitrogen Placement Study

360 Bandit™: Figure 3.

Streams fertilizer 3" off the side of row
and ¾" in depth



Figure 3.



Conceal®: Figure 4.

Injects fertilizer 3" off the side of row,
1.5" in depth with knife placed in center
of gauge wheels.



Figure 4.



At-Plant Nitrogen Placement Study

Results: Table 1. illustrates Dual band Conceal® treatments offered highest yields in the study at 269.1 Bu/A.. Conceal® system is a unique planter attachment that allows growers to place nitrogen in a high concentration dual or single band positioned 3” away from the seed trench (Figure 3.) at depths near 1.5”. Conceal® system uses existing planter space, utilizing a backswept knife located with-in the center of the planter’s gauge wheels. As nitrogen is applied, it is sealed within the soil profile by the gauge wheels, preventing potential volatilization losses that are typically problematic with surface type nitrogen applications.

Conversely, surface dribble treatments proved lowest corn yield with reductions of **-6.3 Bu/A.** Volatilization is a form of N loss that occurs when nitrogen is applied on the soil surface without incorporation by tillage or rainfall events. In this event, applied nitrogen converts to ammonia, a gaseous form that can easily escape into the atmosphere. Volatilization can occur if coulter/knife slots open or UAN is exposed to sunlight, air, wind, and increased temperatures after application.

360 Bandits™ resulted in losses of **-4.1 Bu/A.**, compared to the dual band Conceal® system. In evaluating this system, it appeared that not all fertilizer was incorporated or “sealed”, which lead to placement depth error and potential volatilization issues.

John Deere® 2X2 units proved **-1.1 Bu/A.** losses compared to the Conceal® system and performed the best relative to 360Bandits™ and the dribble tubes.

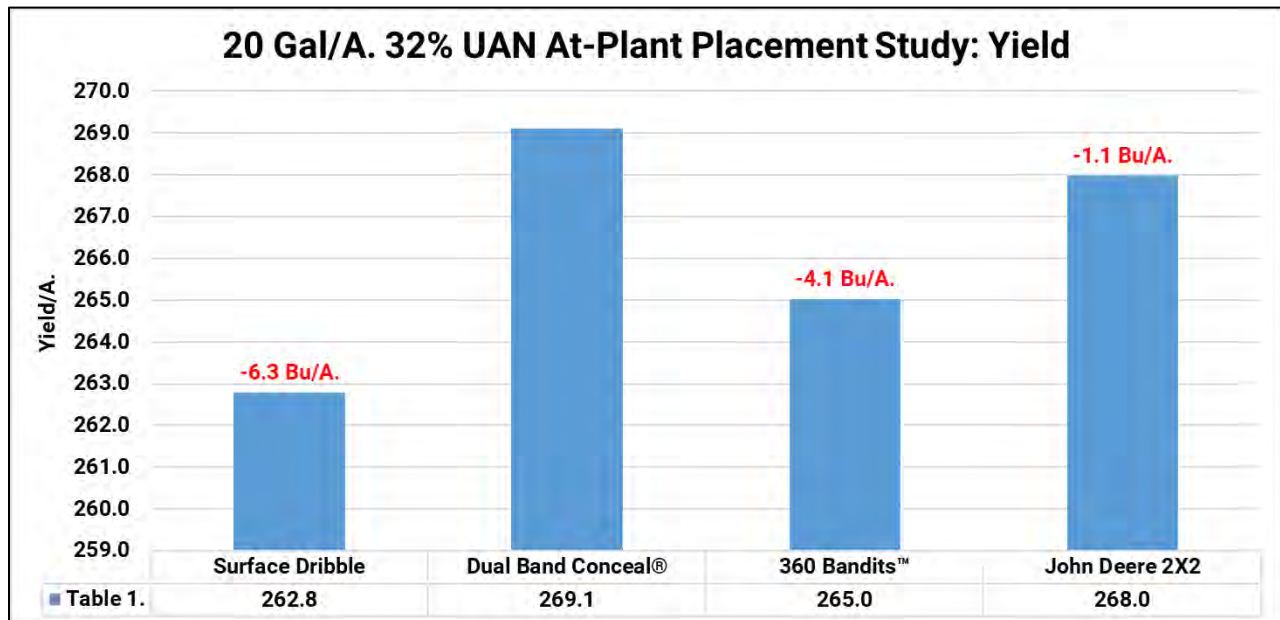

At-Plant Nitrogen Placement Study

Table 2. below illustrates net revenue lost for each nitrogen placement system compared to Conceal® dual band treatments. Surface dribble applications recorded losses of **-\$37.95**, 360Bandits™ at **-\$24.45/A.** and John Deere® 2X2 at **-\$6.75/A.**

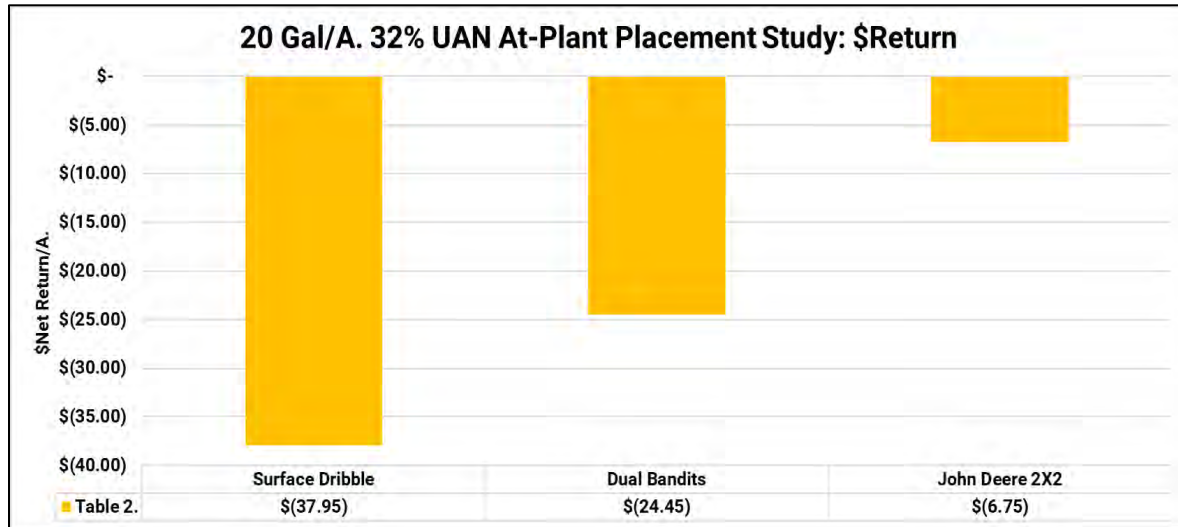

Now that we know performance of each system as a baseline, we can understand the true cost of each system. Assuming a grower would purchase a system and implement it on their farm for at least 3 years, we can calculate the actual realized cost/row for a 16 row planter build. At the end of 3 crop seasons (assuming 2022 yield data annually), adding the actual cost of the row units plus the estimated crop loss on a per acre basis, we can establish what the potential true realized cost would be. The table below illustrates dribble tubes would actually cost a whopping \$7166/planter row, 360Bandits™ at \$4919/row and John Deere® 2X2 at \$4466/row. All compared to the original \$1000/row for Conceal®.

Product	System Cost/Row	16Row Build Cost	\$Crop Loss/A.	Acres	3Yr Total Cost	Realized Cost/Row
Conceal®	\$1,000.00	\$16,000.00	-	1000	\$16,000	\$1,000
Dribble	\$50.00	\$800.00	\$37.95	1000	\$114,650	\$7,166
360Bandits™	\$335.00	\$5,360.00	\$24.45	1000	\$78,710	\$4,919
JD 2X2	\$3,200.00	\$51,200.00	\$ 6.75	1000	\$71,450	\$4466

In summary, growers sometimes look at initial cost of an item to dictate their purchase decisions, rather than the actual true cost after evaluating performance and return on investment.

Nitrogen Sealer Study

Objective: To evaluate the yield and economic impact of implementing nitrogen sealers when side-dressing corn with liquid nitrogen (N). Nitrogen sealers from Nitrogen Sealing Systems in Catlin, IL are a pair of coulters that attach to a side dress unit behind the knife or high-pressure injection nozzle (Figure 1-2). Sealers are designed to lift and redirect soil over top of the injection point of nitrogen, collapsing and sealing the trench, protecting nitrogen that could otherwise volatilize.

Volatilization is a form of N loss that occurs when nitrogen is applied on the soil surface without incorporation by tillage or rainfall events. In this event, applied nitrogen converts to ammonia, a gaseous form that can easily escape into the atmosphere. In a side-dress situation, this can occur when nitrogen is applied and not sealed or covered properly. If coulters slots open or become exposed to sunlight, air, wind, and increased temperatures after application, volatilization can occur.

Results: Tables 1-2. illustrate nitrogen sealers offering yield gains of +5.4 Bu/A., while capturing an additional \$32.40/A. Multi-year data over 2020-2022 have proved +8.4 Bu/A. yield gains that have resulted into economic gains of +\$39.23/A.

At a cost of \$285/row on a 15-knife side-dress applicator, break-even would occur at 109 acres.



Figure 1. Nitrogen Sealers



Figure 2. Sealed row with soil berm

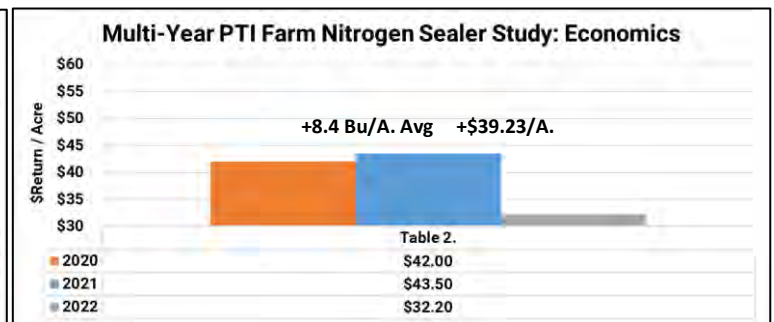
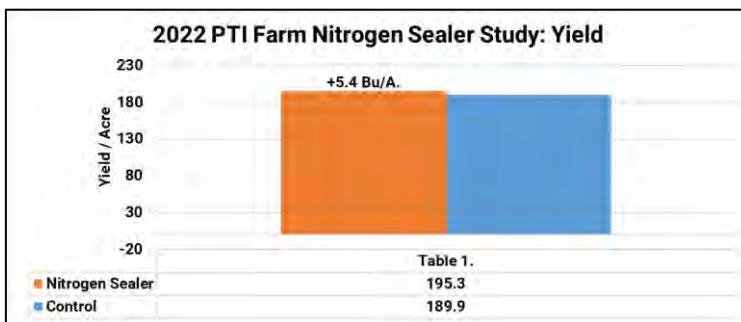

Planting Date: 5/15

Hybrid: Golden Harvest 15J91

Population: 36K

Row Width: 30"

Rotation: CAC

Corn Price: \$6.00

Side-Dress Timing: V3

Sealers from Nitrogen Sealing Systems \$285/Row

Conceal® K-Fuse® Potassium Study

Objective: To evaluate the yield and economics of NACHURS® K-Fuse® powered by Bio-K® (Figure 1.), a 6-0-12-12S potassium/sulfur product designed to be blended with UAN fertilizer and applied on the planter or at side-dress. For this study we applied three, five, and eight gallons of K-Fuse® at planting in a dual band Conceal® system application tank-mixed with 27 Gal/A. of UAN 32%. (Figure 2).

Results: Table 1. illustrates K-Fuse® applications reached agronomic optimum yield at the highest 8 Gal/A. Yield response ranged from +6.8 Bu/A. to +9.3 Bu/A.

As for economics, Table 2. reveals 3 Gal/A. of K-Fuse® provided economic optimum rate with a positive return on investment of +\$21.00.

Multi-year data from 2019, 2020, and 2021 have proven yield gains of +11.4 Bu/A. along with positive return on investment of +\$27.81/A. at the 5 Gal/A. rate.

Figure 1. Nachurs K-Fuse® Potassium Additive

NACHURS®

NUTRIENTS SUPPLIED (pounds per gallon):
 Total Nitrogen (N) 0.65
 Soluble Potash (K₂O) 1.30
 Sulfur (S)..... 1.30

Derived from: Potassium Acetate, Ammonium Thiosulfate, and Urea.

PRODUCT PROPERTIES:
Analysis:..... 6-0-12-12S
Weight:..... 10.8 lbs. per gallon
Specific gravity:..... 1.30 kg/L
pH:..... 7.4-7.9
Appearance:..... Clear, nearly colorless
Odor:..... Ammonia odor

GENERAL PRODUCT INFORMATION:
NACHURS K-Fuse is designed to be blended with various other fertilizers to provide important nutrients needed to grow high-yielding crops. Primarily, **NACHURS K-Fuse** should be blended with UAN solutions for sidedress and/or fertigation application to provide two very critical elements - Potassium and Sulfur. It can also be mixed with APP and UAN for 2x2 and/or strip-till application to provide a more balanced nutrient program. **NACHURS K-Fuse** contains a proprietary additive which allows for more narrow mixing ratios with UAN solutions than other potassium products currently on the market. Always follow mixing recommendations so as to limit risk potential of forming low solubility potassium nitrate compounds. **NACHURS K-Fuse** should not come in close proximity to the seed under any circumstance (i.e. in-furrow placement).

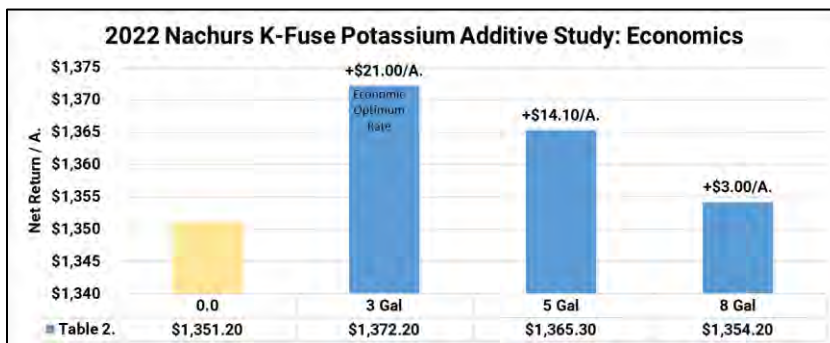
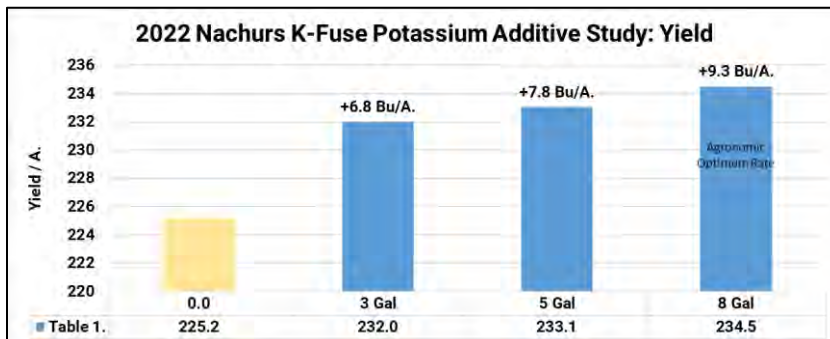

Figure 2. Conceal Dual Placement 3" from Seed Furrow, 1.5" in Depth

Conceal® Holganix® Bio800+ Study

Objective: Holganix Bio 800+ Agriculture contains an entire microbiome or community of organisms that is both abundant and diverse. In a single jug of Holganix Bio 800+ Agriculture, there are more than 800 species of active microbes, microbe food, and nutrient enhancers. Some of the soil microbes contained in Holganix Bio 800+ Agriculture include both Phosphorus and Micronutrient Solubilizing Bacteria, Nitrogen Fixing Bacteria, Plant Growth-Promoting Bacteria, Plant Debris Degrading Bacteria and Fungi, Mycorrhizae Fungi, Trichoderma Fungi, Penicillium Fungi, Beneficial Nematodes, and Protozoa.

For this study, Holganix is applied an at-plant dual band Conceal® application (Figure 1).



Figure 2. Conceal Dual Placement 3" from Seed Furrow, 1.5" in Depth

Results: Table 1. Illustrates Holganix® Bio-800+ resulted in in yield gains of +5.9 Bu/A. At \$6 corn and \$18/A. cost of product, positive economic gains tallied in at \$17.40/A. As a 1st year product testing, we look forward to future testing with this product at the PTI Farm.

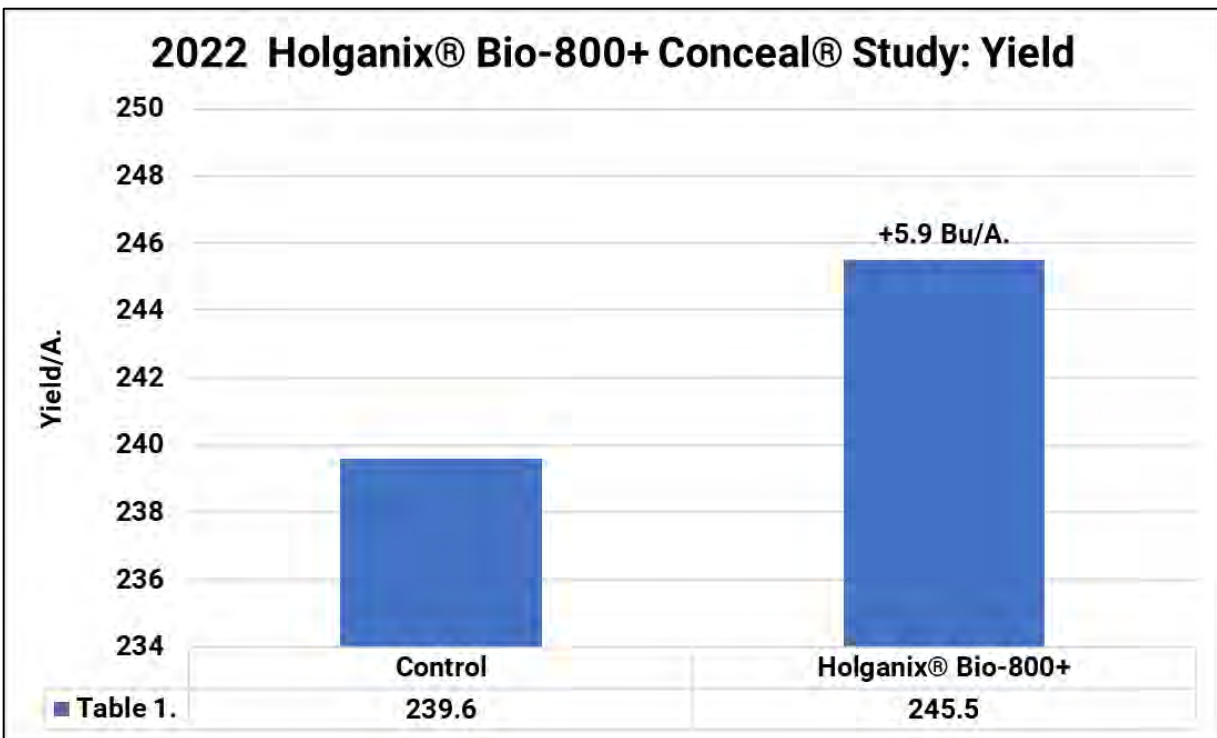

Conceal® Nitrogen Placement in Cover Crop Study

Objective: This trial is designed to evaluate the differences in yield and economic benefits of a dual band Conceal® system liquid nitrogen application, compared to planter banded applied dry urea nitrogen application in a ryegrass cover crop environment.

Conceal® is a unique planter attachment that allows growers to place nitrogen in a high concentration dual or single band positioned 3" away from the seed trench (Figure 2.) at depths near 1.5". Conceal® system uses existing planter space, utilizing a backswept knife located with-in the center of the planter's gauge wheels. As nitrogen is applied, it is sealed within the soil profile by the gauge wheels, preventing potential volatilization losses that are typically problematic with surface type nitrogen applications.

For this study, 45#/A. of a cereal rye was planted in the fall of 2021. After the rye emerged, fall strip-till was then completed to create an ideal seedbed in 30" rows. In the spring, corn was planted into the strips, with the green cover crop. Termination of the ryegrass was made at the V2 growth stage.

To monitor nitrogen performance, a surface applied planter band of urea nitrogen was applied over the planted corn row. This pre-emergence application was only made on the strip-till bands.

All treatments totaled 180# nitrogen, with 65# (actual N) applied as either a surface band urea or Conceal® pre-emerge N. In addition, all treatments received 115# of nitrogen applied as a V4 side-dress.



Figure 4. Urea Applicator on Planter

Figure 1. Fall Cover Crop Seeding



Figure 2. At-Plant Conceal® Dual Band Nitrogen



Figure 3. At-Plant Banded Urea



Conceal® Nitrogen Placement in Cover Crop Study

Results: Table 1. illustrates at-plant Conceal® dual band applications of nitrogen resulted in additional yield gains of +6.9 Bu/A. compared to surface applied banded urea nitrogen. At \$6 corn, these yield gains would result in revenue gains of +\$41.40/A.

Sealing nitrogen into soil moisture is key with applying nitrogen without risk for volatilization. Urea can be a really effective source of nitrogen, however when surface applied and not incorporated, gassing off is a risk. Extremely dry and windy conditions persisted after planting, which more than likely accounts for the performance differences.

Feeding a corn crop in a cover crop system can be challenging in itself. If we compound the issue and create a nitrogen aspect in addition, yield and overall economics can be drastically affected.

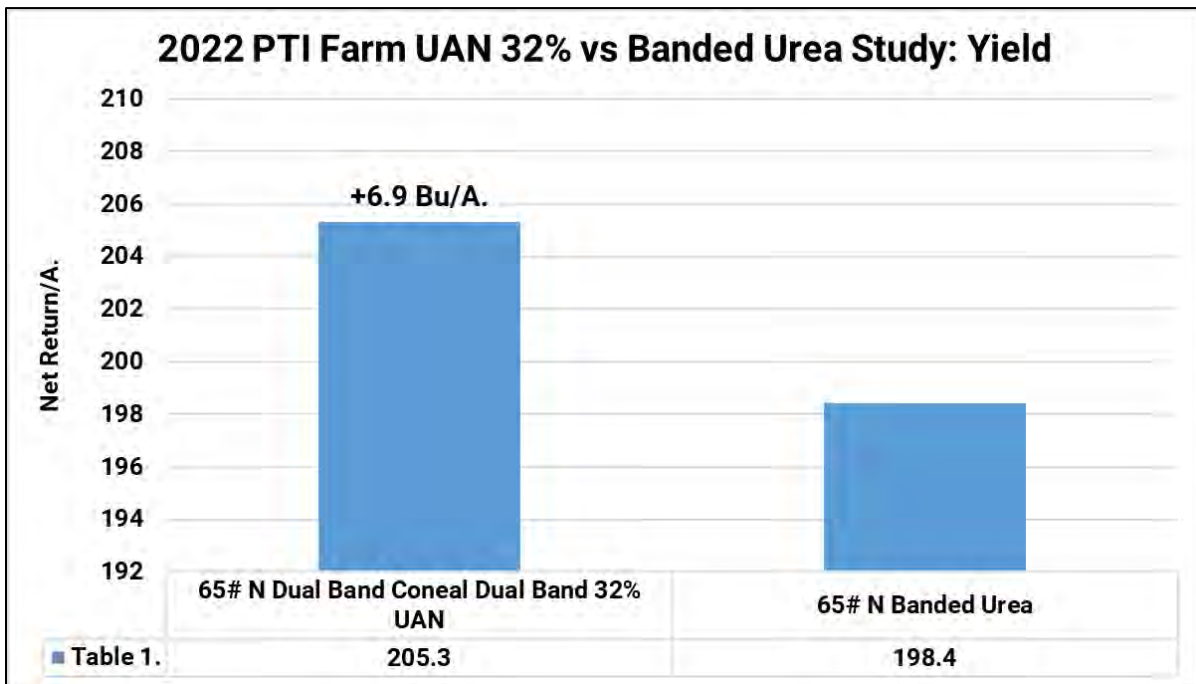

Aqua-Yield® NanoN+® Conceal® Nitrogen® Study

Objective: To evaluate yield and economics of NanoN+® by AQUA-YIELD. NanoN+® uses AquaYield nanoliquid technology to improve nitrogen use efficiency. NanoN+® can be added to most liquid fertilizer blends containing nitrogen to enhance uptake. Nanoliquid products effectively work as a deliver system for nutrients and protects molecules from environmental losses and delivers them them to plants at the cellular level. A process called endocytosis brings the nanoliquid particles into the cell where the payload is delivered.

Figure 1. Conceal Placement



This trial aims to establish the efficiency of Aqua-Yield's NanoN+® nano-liquid based fertility product in tandem with 32% UAN nitrogen fertilizer. NanoN+® was applied at planting in a dual band Conceal® application (Figure 1).

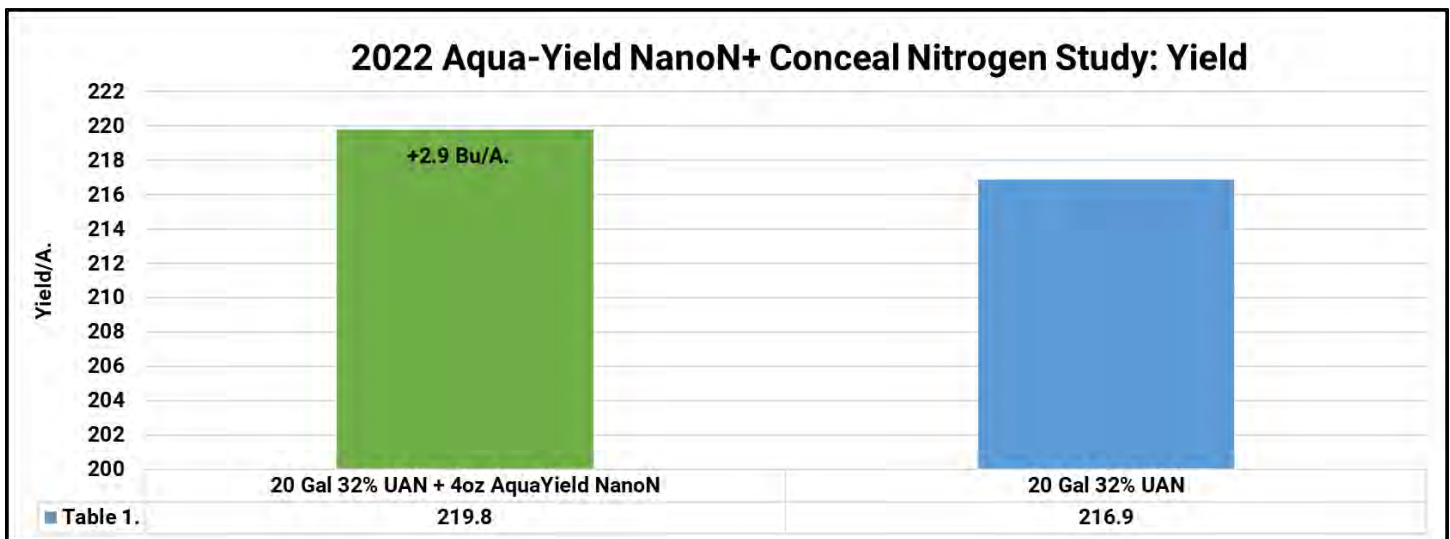

AQUA-YIELD®

NanoN+™

Aqua-Yield® NanoN+® Conceal® Nitrogen Study Continued

Results: Table 1. illustrates yield results of all treatments. Aqua-Yield's NanoN+® tank-mixed with 20 Gal/A. of 32% UAN resulted in +2.9 Bu/A. yield improvement over the control.

Table 2. illustrates the overall economics of the fertility study where NanoN+® resulted in positive economic gains of +\$11.18/A.

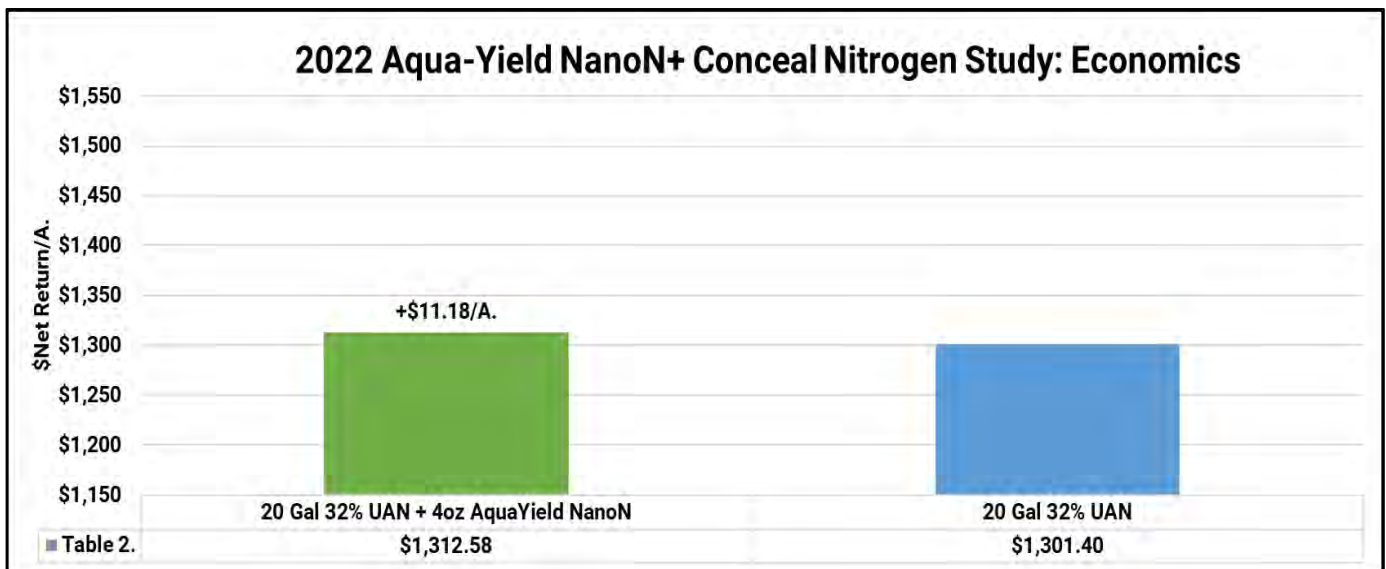
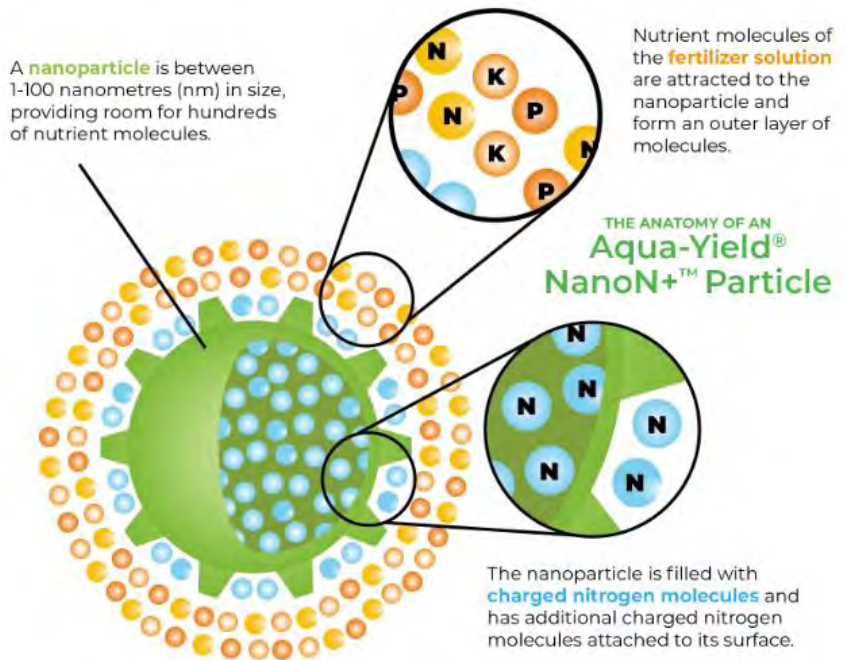

PhycoTerra® Conceal® Soil Amendment Study

Objective: To evaluate yield and economics of PhycoTerra®, a liquid microbial food product that delivers a superior, balanced meal to the starving, dormant microbes in soil. PhycoTerra® activates the soil microbiome (up to 33x) by delivering a superior balanced meal to dormant, native microbes. Waking up microbes, both bacteria and fungi, early in the season can help support your crop throughout the growing season. PhycoTerra® delivers a unique mode-of-action to improve soil structure, increase water holding capacity, and optimize nutrient (NPK) availability. Improved soil quality and health supports crops through abiotic stress throughout each crop season.

Figure 1. Conceal® Placement



PhycoTerra® was applied at planting in a dual band Conceal® application (Figure 1).

PhycoTerra® **Wakes Up the Microbiome**

- PhycoTerra® provides super food to the microbiome
- PhycoTerra feeds microbes & puts them to work
- An active microbiome improves soil structure, promoting healthy crops



Product Type	g Food/L	g Protein per L	g Lipids per L	g Carb per L	g Ash per L
Molasses Product	74	4	0.8	60	10
Humic Acid Product	7	1	0.12	2	4
Seaweed Product	32	1	0.5	15	15
PhycoTerra®	92	24	21	44	3

PhycoTerra® Conceal® Soil Amendment Study

Results: Table 1. illustrates dual band treatments of PhycoTerra® resulted in yield gains of +4.1 Bu/A. At a product cost of \$10/A., positive net returns of +\$14.60/A. were realized.

It should be noted that this study was a late planted corn trial (June 16th). As a result, it was unknown how it would affect trial performance. The +4.1 Bu/A. is interesting to see and we look forward to see how this product could work in more typical planting date/conditions. We will also be using PhycoTerra® through means of irrigation drip tape throughout the growing season in addition to planter applied Conceal® treatments.

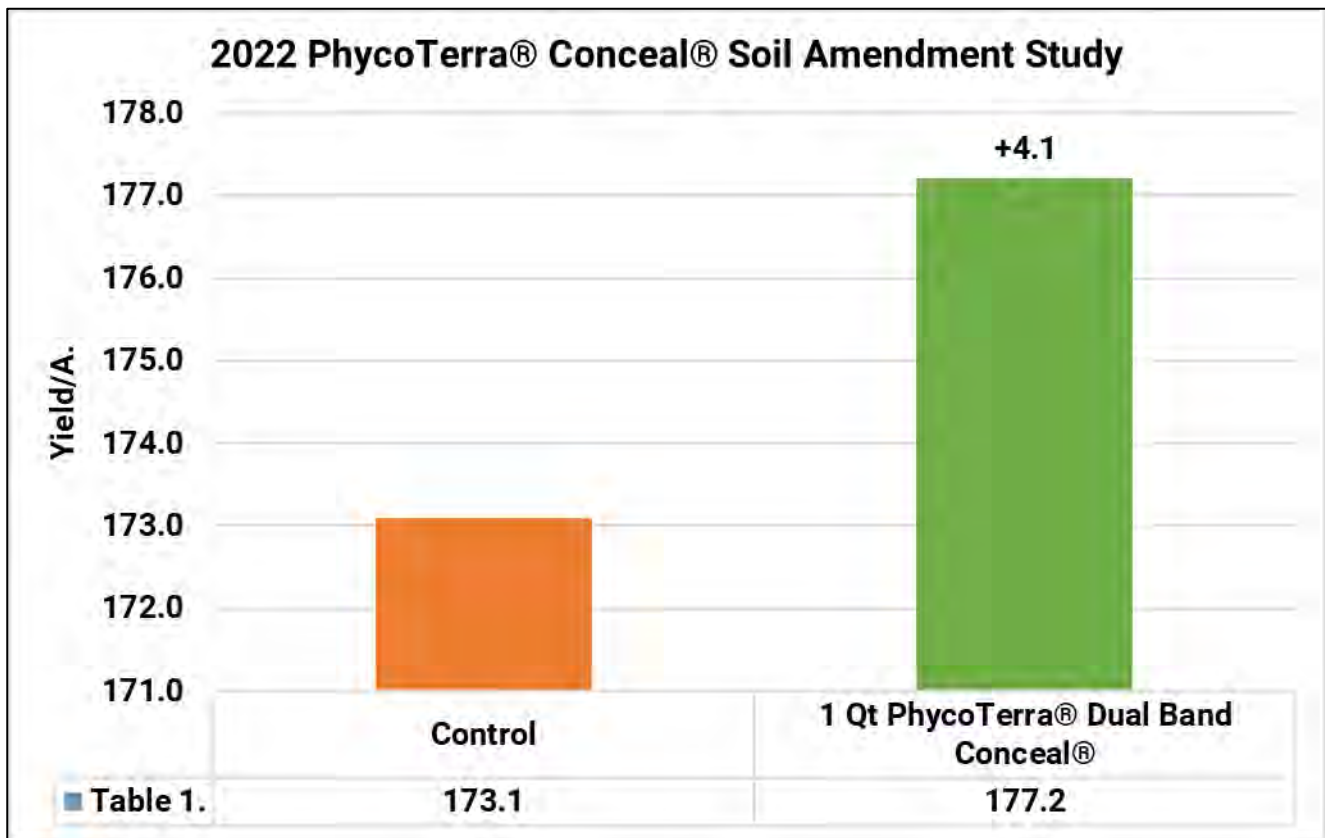

Corn 2022 Summary of Conceal® Applications

Study	Classification	Yield (Bu/A.)	\$ROI	Page #
Dual Conceal vs WNF	Nitrogen	10.2	\$ 61.20	114
Dual Band Conceal over Banded Urea	Nitrogen	6.9	\$ 41.40	123-124
Conceal over Dribble	Nitrogen	6.3	\$ 37.95	116-119
Dual Band over Single Band Conceal	Nitrogen	5.6	\$ 33.60	115
Nachurs Start to Finish	Starter, Potassium	9.5	\$ 31.44	85
Single Conceal vs WNF	Nitrogen	4.6	\$ 27.60	114
Conceal over 360™ Bandits	Nitrogen	4.1	\$ 24.45	116-119
Nachurs K-Fuse 3 Gal	Potassium	6.8	\$ 21.00	121
Holganix Bio 800+	Biological	5.9	\$ 17.40	122
Phosphorus Placement - Conceal 5Gal 10-34-0	Phosphorus Efficiency	2.3	\$ 16.55	100-101
Nachurs K-Fuse 5 Gal	Potassium	7.8	\$ 14.10	121
Aqua-Yield NanoN+	Nitrogen Enhancer	2.9	\$ 11.18	125-126
Xyway LFR Conceal	Fungicide	5	\$ 10.00	106-108
Ocean Blue Ag 80oz Nutrishield in Furrow + 6 Gal Power Pro Conceal	Starter Fertilizer	5.6	\$ 9.56	80-82
May 11th Corn Planting Date with Starter	Starter Fertilizer	12.1	\$ 8.20	8-9
May 2nd Corn Planting Date with Starter	Starter Fertilizer	12.0	\$ 7.60	8-9
Conceal over JD 2X2	Nitrogen	1.1	\$ 6.75	116-119
April 26th Corn Planting Date with Starter	Starter Fertilizer	11.8	\$ 6.40	8-9
Phosphorus Placement - Conceal 10Gal 10-34-1	Phosphorus Efficiency	5.1	\$ 6.10	100-101
QLF Boost Nitrogen Inclusion: 5Gal Boost + 10% N Reduction	N, Carbon Based Sugar	1.4	\$ 4.94	92-93
Nachurs K-Fuse 8 Gal	Potassium	9.3	\$ 3.00	121
May 20th Corn Planting Date with Starter	Starter Fertilizer	10.9	\$ 1.00	8-9
June 6th Corn Planting Date with Starter	Starter Fertilizer	7.6	\$(18.80)	8-9
Average		6.73	\$ 16.64	



Conceal 3" away, 1.5" deep from the seed trench



Continuous Corn Cover Crop Study

Objective: This trial is designed to evaluate the yield and economic benefits of a cover crop system in a continuous corn rotation. To evaluate long-term benefits, this trial has been designed as a 10-year study. 45#/A. of cereal ryegrass was planted in the fall of 2021 and fall strip-till was used as the primary tillage system for corn. In the spring, corn was planted directly on the fall strips into the green cover crop. The ryegrass was terminated at V2.

Figure 1. Fall Cover Crop Seeding

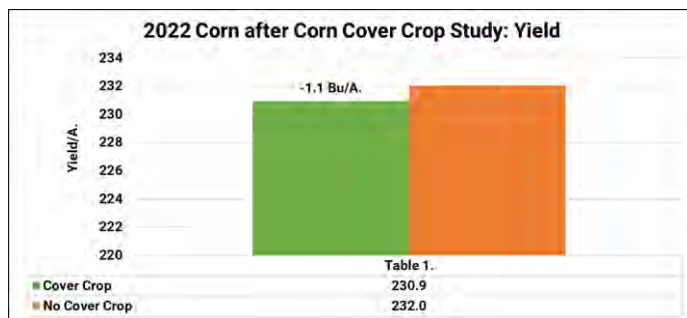
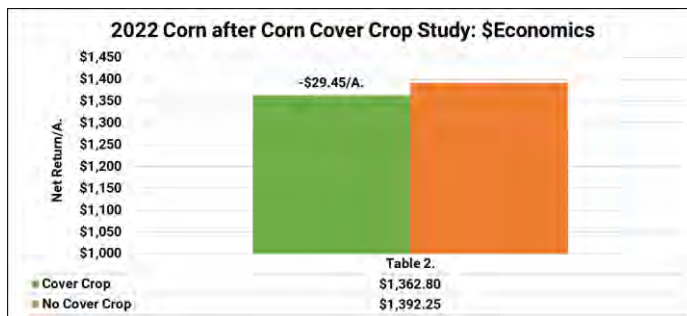

Figure 2. Planting into Strip-Till with Green Cover



Results: Continuous corn planted into our 2nd year of our 10-yr study proved **-1.1 Bu/A.** yield losses compared to a non-cover crop system. Table 1. illustrates the near identical corn yield of the two systems.

Due to the absence of yield gain, Table 2. depicts average losses of **-\$29.45/A.** for year two of our long-term study. 2021 data proved very similar results with yield losses of **-1.2 Bu/A.** and economic losses of **-\$28.88/A.**

We look forward to continuing to test the use of cover crops in a continuous corn rotation and to evaluate yield, economics of the system, while taking a close look at what cover crops can offer regarding soil health improvement.

Corn after Soybean Cover Crop Study

Objective: This trial is designed to evaluate the yield and economic benefits of a cover crop system in a corn/soybean corn rotation. To evaluate long-term benefits, this trial has been designed as a 10-year study. 45#/A. of cereal rye was planted in the fall of 2021 and fall strip-till was used as the primary tillage system for corn. In the spring, corn was planted directly on the fall strips into the green cover crop. The ryegrass was terminated at when corn reached the V2 growth stage.

Figures 1-2. Planting into Strip-Till with Green Cover

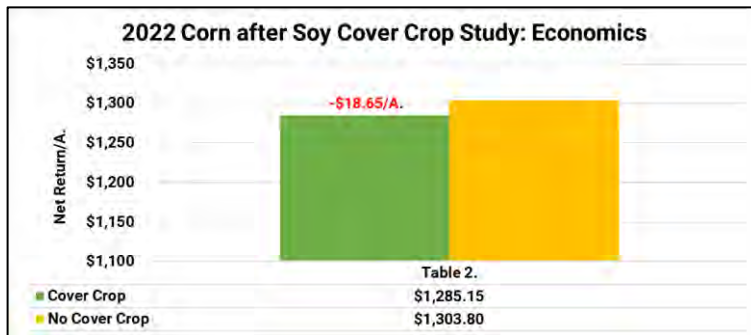
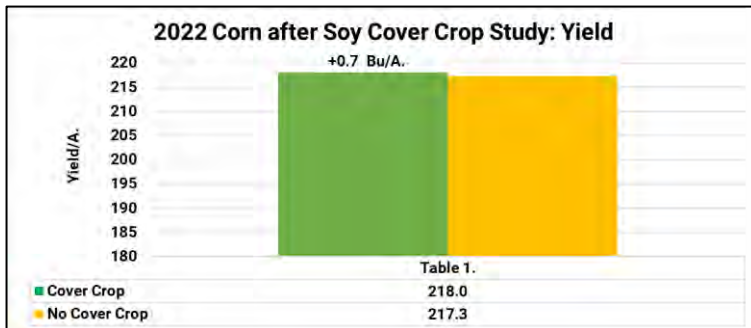

Results: Corn planted into our 2nd year of our 10-yr study once again proved nearly identical yield compared to a non-cover crop system. (Table 1.) Both systems yielded within 0.7 Bu/A. of each other.

However, Table 2. depicts average losses of **-\$18.65/A.** for the cover crop system. While only in our second year, multi-year data suggests minimal average yield losses of +0.3 Bu/A., but more importantly average economic losses of **-\$20.75/A.**

We look forward to continuing to test the use of cover crops in a corn/soybean rotation and to evaluate yield, economics of the system, while taking a close look at what cover crops can offer regarding soil health improvement over time.

15" Narrow Row Corn Seeding Rate Study

Objective: This trial evaluates a narrow system of 15" rows with five seeding rates of 32K, 36K, 40K, 44K and 48K. Two hybrids consisting of Dekalb® 64-64 and Golden Harvest® 15J91 are used to help identify differences in plant type response.

Results: Table 1. illustrates that Dekalb® 64-64 achieved agronomic yield at the 44K seeding rate at 259 Bu/A. As seeding rates were pushed higher to 48K, yield fell by **-10.7 Bu/A.** As seeding rate was decreased below 44K, yield dropped by **-0.2 Bu/A.** at 40K, **-9.3 Bu/A.** at 36K and **-13.5 Bu/A.** at 32K.



Table 2. represents the economics and tells the true story of which seeding rate offered highest net return. 40K seeding rates achieved economic optimum seeding rate. Pushing seeding rates to 44K decreased net revenue by **-\$13.80/A.**, while going up to 48K proved too costly at **-\$92.70/A.** Dropping seeding rate under 40K resulted in **-\$39.60/A.** losses at 36K and **-\$49.80/A.** losses at the lowest 32K seeding rate.

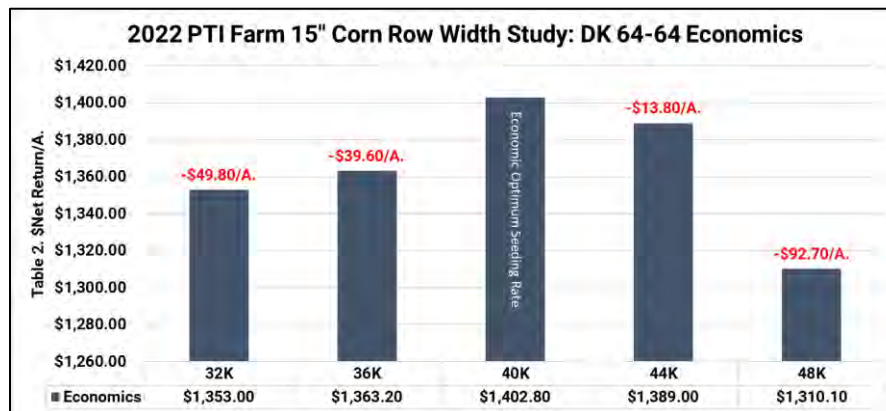
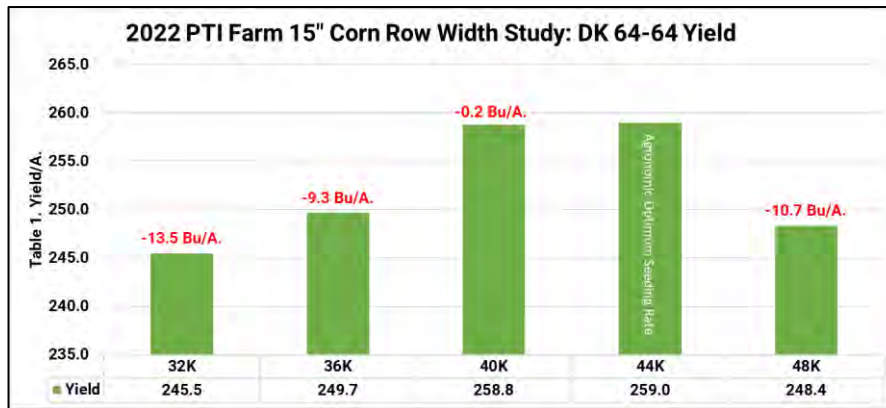

15" Narrow Row Corn Seeding Rate Study Continued

Table 3. illustrates Golden Harvest® 15J91 appeared to prefer higher seeding rates as it achieved agronomic yield at the highest 48K seeding rate at 267 Bu/A. As seeding rates fell, yield fell with it by **-8.1 Bu/A.** at 44K, **-5.7 Bu/A.** at 40K, **-18 Bu/A.** at 36K and **-23.6 Bu/A.** at the lowest seeding rate of 32K.

Table 4. represents the economics and indicates 44K seeding rates achieved economic optimum seeding rate. Pushing seeding rates to 48K resulted in decreased net revenue by **-\$33.30/A.** Dropping seeding rates resulted in net losses of **-\$4.20** at 40K, **-\$63.00** at 36K and finally **-\$81.30/A.** at 32K.

Table 5. summarizes both corn hybrids in yield and net return. On average both optimum agronomic and economic seeding occurred at 40K. When seeding rates were aggressive at the high 44K-48K rates, economics fell by **-\$21.45** to **-\$44.25/A.** As seeding rates fell to 36K and 32K, economics took a tumble and resulted in losses of **-\$49.20** to **-\$63.45/A.** respectively.

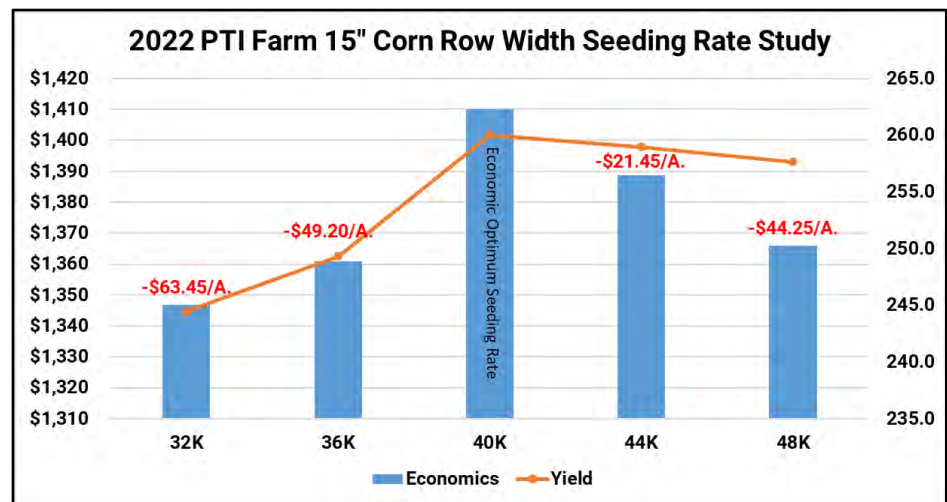
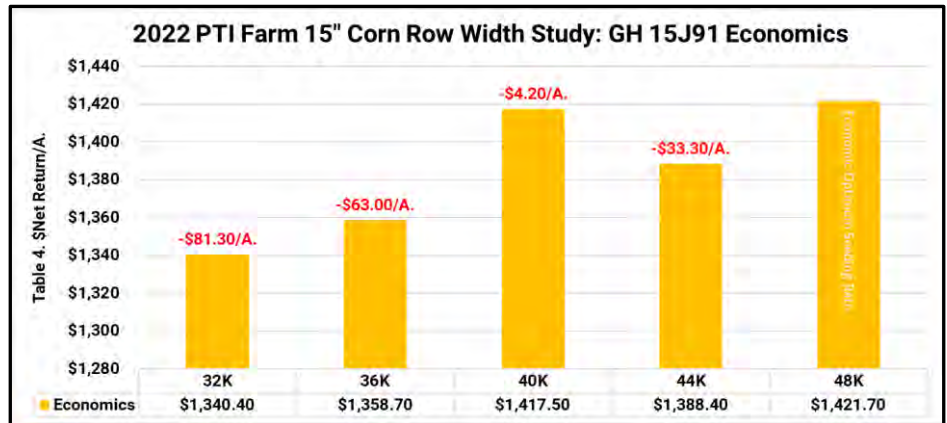
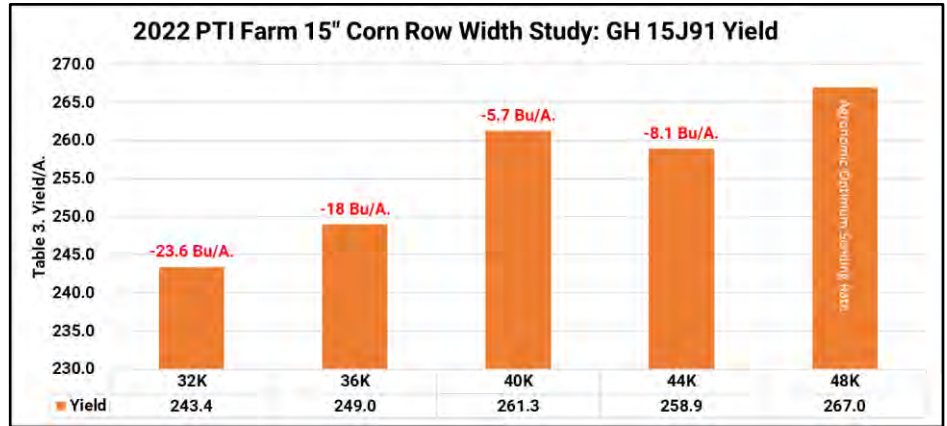

20" Narrow Row Corn Seeding Rate Study

Objective: This trial evaluates a narrow system of 20" rows with five seeding rates of 32K, 36K, 40K, 44K and 48K. Two hybrids consisting of Dekalb® 64-64 and Golden Harvest® 15J91 are used to help identify differences in plant type response.



Results: Table 1. illustrates that Dekalb® 64-64 achieved agronomic yield at the 36K seeding rate at 254.7 Bu/A. Lower 32K seeding rates resulted in yield losses of **-13.5 Bu/A.** Pushing seeding rates higher to 40K and 44K resulted in yield losses of **-3.3/A.** and **-2.2 Bu/A.** respectively.

Table 2. represents economics and indicates 36K being economic optimum seeding rate. Lowering seeding rates to 32K resulted in losses of **-\$66.20/A.,** while increasing seeding rates to 40K and 44K resulted in losses of **-\$35/A.** to **-\$43.40/A.**

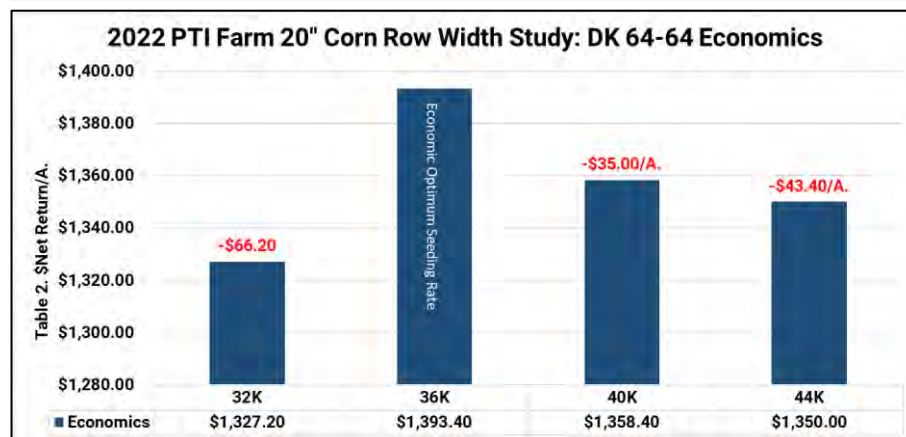
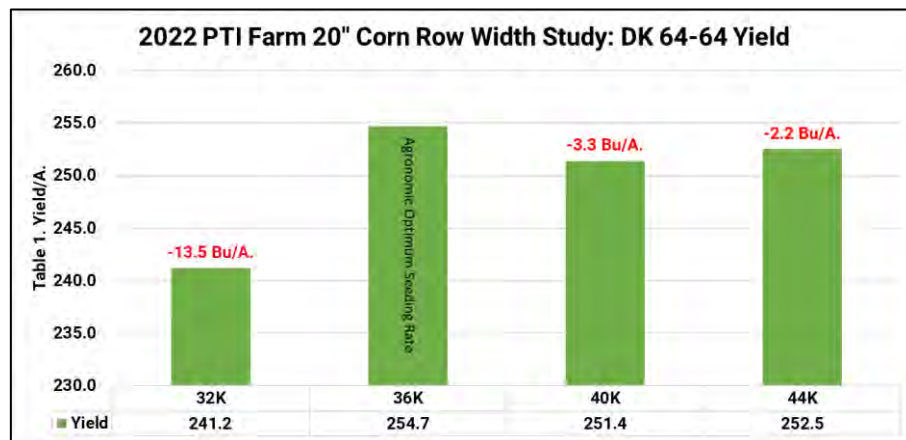

20" Narrow Row Corn Seeding Rate Study Continued

Table 3. illustrates Golden Harvest® 15J91 achieved agronomic optimum yield at the 40K seeding rate at 267.2 Bu/A. As seeding rates fell, yield fell with it by **-15.7 Bu/A.** at 36K and **-23.2 Bu/A.** at the lowest 32K seeding rate. As seeding rate was increased past 40K to 44K, yield also fell **-16.9 Bu/A.**

Table 4. represents the economics and indicates 40K seeding rates achieved economic optimum seeding rate. Pushing seeding rates to 44K resulted in decreased net revenue by **-\$116.40/A.** Conversely, dropping seeding rates resulted in net losses of **-\$79.20/A.** at 36K and **-\$109.20/A.** at the lowest 32K seeding rate.

Table 5. summarizes both corn hybrids in yield and net return. On average both optimum agronomic and economic seeding occurred at 40K.

When seeding rates were aggressive at the higher 44K rates, economics fell by **-\$62.40/A.**

Lower 32K to 36K seeding rates reduced net revenue by **-\$22.10/A.** to **-\$70.20/A.**

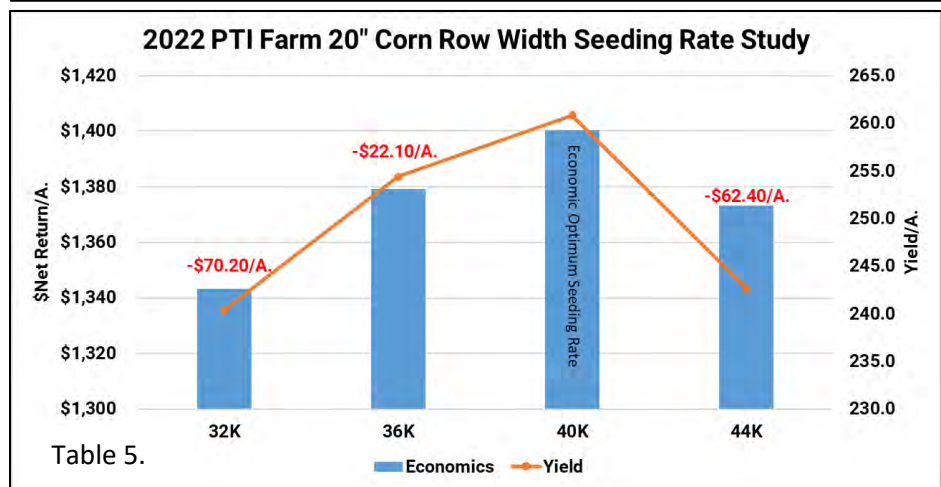
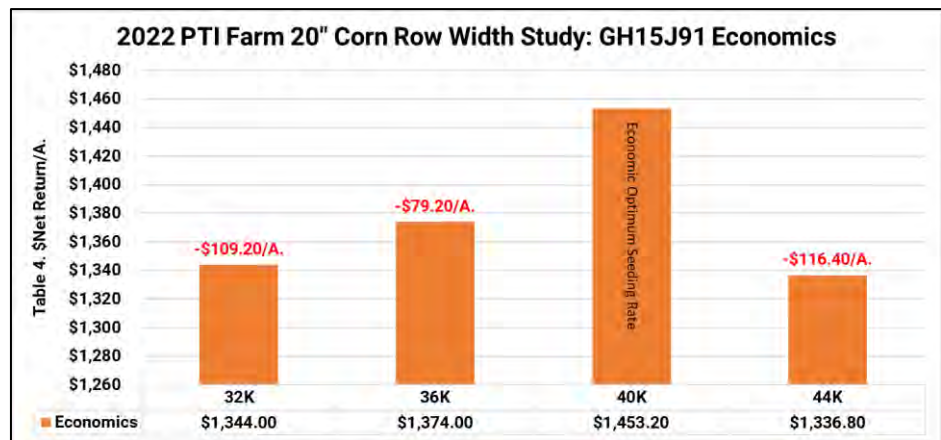
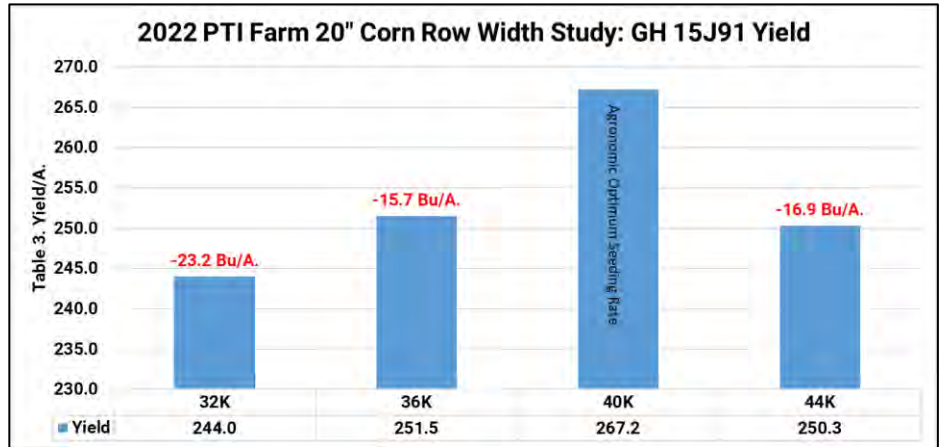

30" Row Corn Seeding Rate Study

Objective: This trial evaluates 30" rows with four seeding rates of 32K, 36K, 40K, and 44K. Two hybrids consisting of Dekalb® 64-64 and Golden Harvest® 15J91 are used to help identify differences in plant type response.



Results: Table 1. illustrates that Dekalb® 64-64 achieved agronomic yield at the 44K seeding rate at 245.5 Bu/A., however there was only a 7.7 Bu/A. variance between all seeding rates.

36K and 40K rates resulted in minimal yield losses of only **-2.1 to -2.4 Bu/A.**, however the highest yield loss proved at the lowest 32K seeding rates at **-7.7 Bu/A.**

Table 2. represents economics and indicates 36K being economic optimum seeding rate. Lowering seeding rates to 32K resulted in losses of **-\$16.80/A.**, while increasing seeding rates to 40K and 44K resulted in losses of **-\$13.20/A. to -\$15.60/A.**

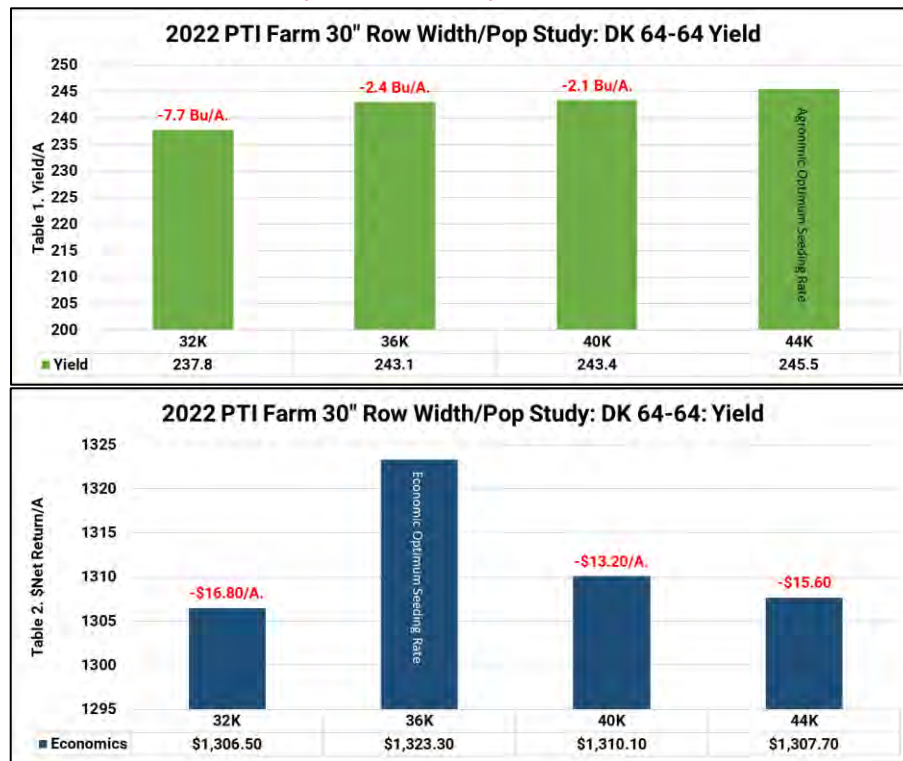

30" Corn Seeding Rate Study Continued

Table 3. illustrates Golden Harves®t 15J91 achieved agronomic optimum yield at the 40K seeding rate at 257.0 Bu/A. As seeding rates fell, yield fell with it by only **-3.6 Bu/A.** at 36K, but to a larger degree of **-13.5 Bu/A.** at the lowest 32K seeding rate. As seeding rate was increased past 40K to 44K, yield also fell, but only by **-2.0 Bu/A.**

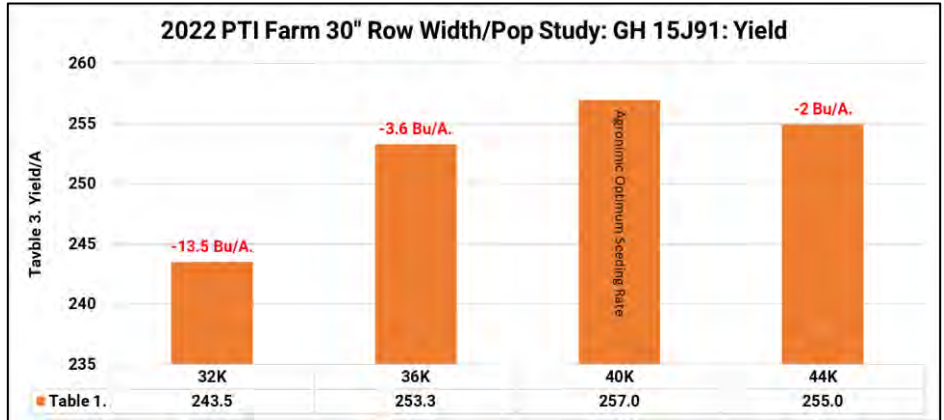

Table 4. represents the economics and indicates 40K seeding rates achieved economic optimum seeding rate. Pushing seeding rates to 44K resulted in decreased net revenue by **-\$27.00/A.** Conversely, dropping seeding rates resulted in net losses of just **-\$6.90/A.** at 36K and **-\$50.70/A.** at the lowest 32K seeding rate.

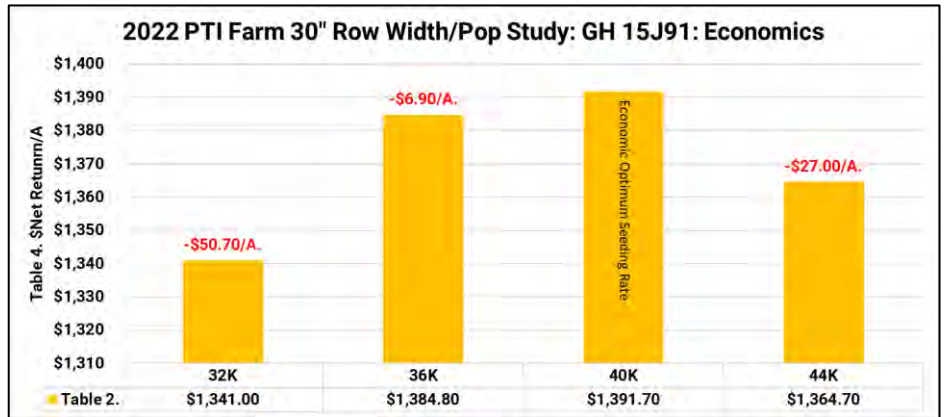
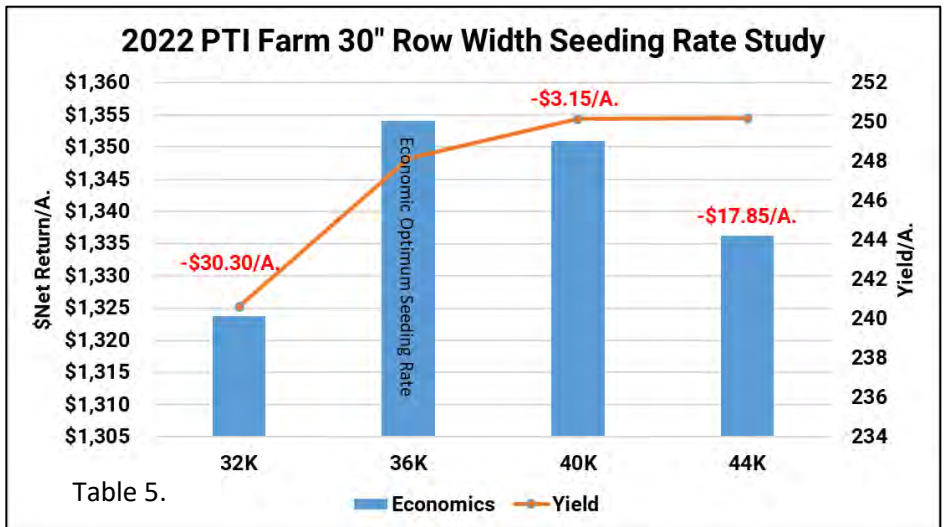

Table 5. summarizes both corn hybrids in yield and net return. While it's surprising that agronomic optimum yield was a dead heat at 40-44K, economics shows the clear evidence. Economic optimum seeding rate occurred at the 36K population, while 40K rates only proved **-\$3.15/A.** losses. The bookends of 32K and 44K proved highest losses of **-\$30.30/A.** on the low end and **-\$17.85/A.** on the high end.



30" vs 20" Corn Row Width Study

Objective: This trial evaluates the industry wide standard of 30" row corn, to that of a narrower system of 20" rows. For this study, the control used is 30" row corn at seeding rates of 36K, as this is the most common row width and seeding rate at the PTI Farm currently.

Results: Tables 1-2. illustrate 30" rows planted at 36K seeding rates compared to 20" narrow row systems at seeding rates of 32K, 36K, 40K and 44K.

20" rows planted at low seeding rates of 32K resulted in yield losses of **-5.6 Bu/A.** with corresponding net economic losses of **-\$18.45/A.**

As seeding rates moved higher from 32K, all seeding rates proved higher yields than 30" rows planted at 36K. 40K proved the highest overall yield response of +11.1 Bu/A. over the 30" rows with positive economic gains of +\$51.75/A. 36K seeding rates offered +4.9 Bu/A. yield increases, along with economic gains of +\$29.65/A.

As 20" row seeding rates went over 40K, yield response diminished but still offer +3.2 yield gains, but offered net economic losses of **-\$10.65/A.** after the additional seed cost.

In summary, 20" rows did in fact offer yield increases over the industry standard of 30" rows, however only at higher seeding rates than that of 30" rows planted at 36K. In 2022, the sweet spot for 20" rows occurred at 40K seeding rates with increased net revenue of +\$51.75/A.

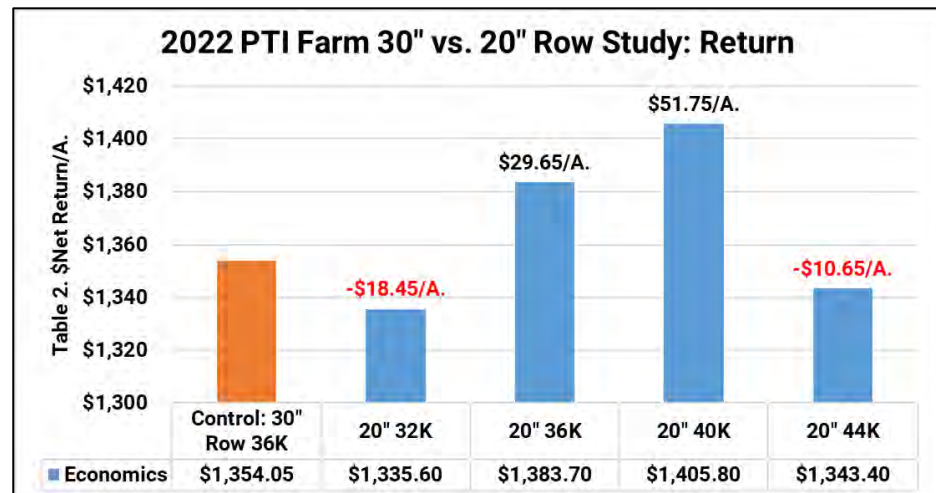
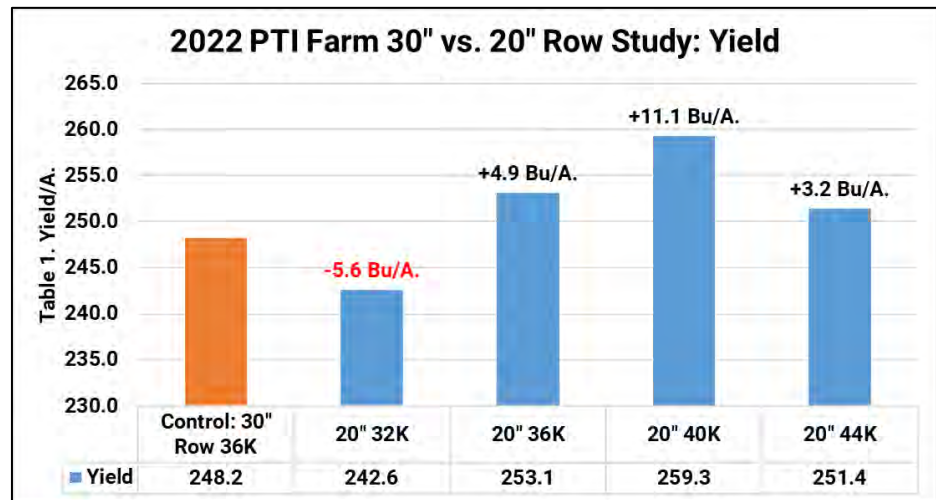

30" vs 15" Corn Row Width Study

Objective: This trial evaluates the industry wide standard of 30" row corn, to a narrower system of 15" rows. For this study, the control used is 30" row corn at seeding rates of 36K, as is this is the most common row width and seeding rate at the PTI Farm currently.

Results: Tables 1-2. illustrate 30" rows planted at 36K seeding rates compared to 15" narrow row systems at seeding rates of 32K, 36K, 40K, 44K and 48K.

15" rows planted at low seeding rates of 32K resulted in yield losses of **-3.7 Bu/A.** with corresponding net economic losses of **-\$7.35/A.**

As seeding rates moved higher from 32K, all seeding rates proved higher yields than 30" rows planted at 36K. 40K proved the highest overall yield response of +11.9 Bu/A. over the 30" rows with positive economic gains of +\$56.10/A.

36K seeding rates offered only +1.2 Bu/A. yield increases, along with economic gains of +\$6.90/A.

In summary, 15" rows did in fact offer yield increases over the industry standard of 30" rows, however seeding rates needed to be at 40K. This seeding rate proved to be the sweet spot for 15" rows with increased net revenue of +\$56.10/A. Pushing seeding rates over 40K proved diminishing returns as yield fell to +10.8 to +9.5 Bu/A. with returns of only +\$34.65/A. to +\$11.85/A. respectively.

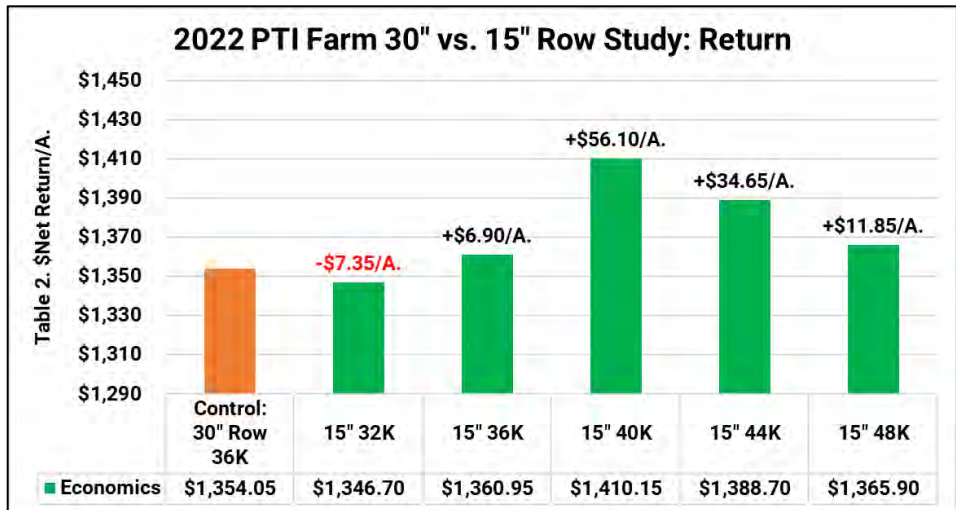
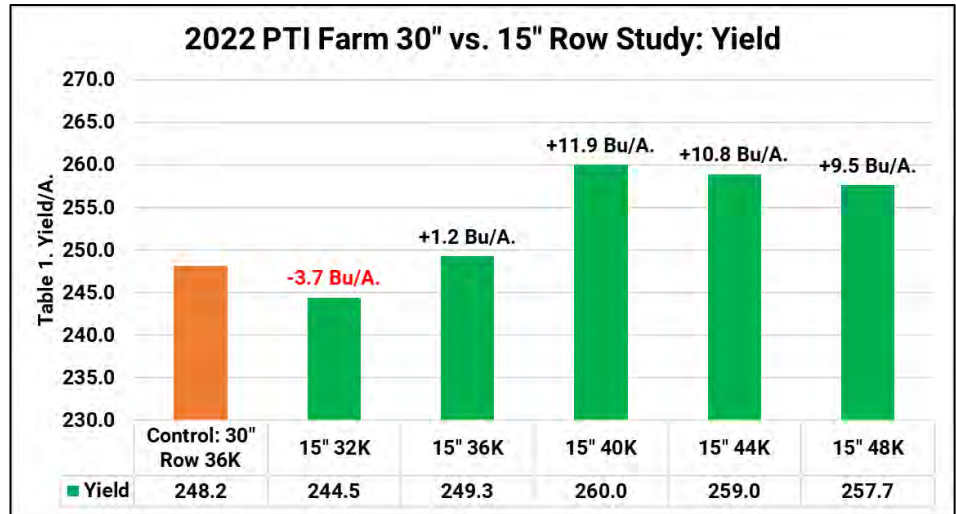

Multi-Year 20" vs 30" Corn Row Width Study

Each year we have thousands of growers that come to the PTI Farm to have a conversation about agronomics. One question we talk about often is corn row width. Many farms today that are on 30" corn rows, say they switched from wide 38" or 36" wide rows back in the early 70's. If this is the case, growers have been implementing 30" row corn systems for nearly 50 years. The question now is, has 50 years been long enough doing the same thing over and over, or is time now for a change to another system that could offer higher yields and profitability?

The question comes down to this; What revenue gain would cause a farmer to run to their local equipment dealer and convert their planters, harvest equipment, tractor tires, side-dress equipment, or even over-all management to narrow rows?

Table 1. illustrates multi-year data over the time-frame of 2019-2022 and reveals 20" rows offering an overall economic advantage of +\$32.25/A. over 30" rows planted at 36K.

Data suggests that 20" narrow rows have not offered much economic gain when planted at seeding rates of only 36K. Higher seeding rates has of 44K to 44K have proved 20" rows to be superior than that of 30" rows, but only by +\$13.68 to

+\$32.25/A. Is this enough to get growers to convert? This is why many feel the adoption rate of narrow corn rows has been slow.

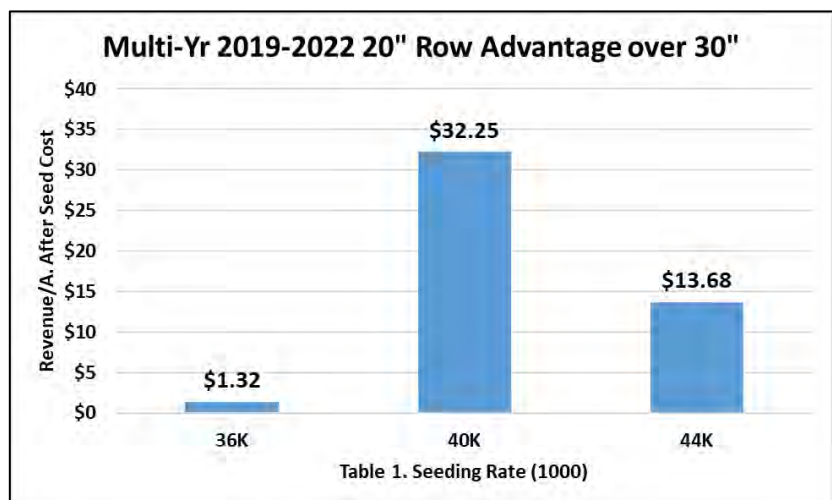

Currently, farm operations that could be a nice fit for narrow rows are:

1. Producers on marginal ground where plant-to-plant competition could be important to conserve water and nutrients.
2. Growers who want to plant at higher seeding rates (above 36-38K) in the effort to "unlock" yield. At these higher pops, 30" rows may not be appropriate and could fail.
3. Growers who want one planter that will also plant soybeans or another crop that prefers to also be in narrow rows.
4. The use of new "short" corn genetics that need higher seeding rates.
5. Growers who have the ability side-dress and/or manage narrow row corn. are not appropriate and would fail.

20" Solar Corridor Study

Objective: This trial's intention is to evaluate any yield or economic advantage in planting 15" row corn in a "solar corridor twin" method at seeding rates of 36K to 48K. A solar corridor is designed as 45" wide rows surrounded by two 15" rows. The theory behind this trial is to increase the distribution of sunlight so that all corn leaves or chloroplasts (regardless of their vertical disposition on the corn plant) receive full access to sunlight the entire growing season. If one of the basic principles of corn yield is maximizing sunlight, could a solar corridor ultimately contribute to increased yield?

Results:

The solar corridor system this year resulted in terrible average yield losses of **-28.6 Bu/A.**, and economic losses of **-\$92.70/A.** compared to traditional 15" rows over all seeding rates. Both systems achieved highest agronomic and economic optimum yield at 48K seeding rates.

The lowest seeding rates in the solar corridor got crushed yield wise with losses of **-48.9 Bu/A.** and economic losses of **-\$225.90/A.** As seeding rates went higher, yield losses were minimized, but lost across the board

Multi-Year data has proven solar corridor economic losses at 36K seeding rates, however as seeding rate has climbed to 40K and 44K, economic gains have occurred at **+\$9.64/A.** and **+\$24.30/A.**



Figure 1. 45" Solar Corridor Corn System

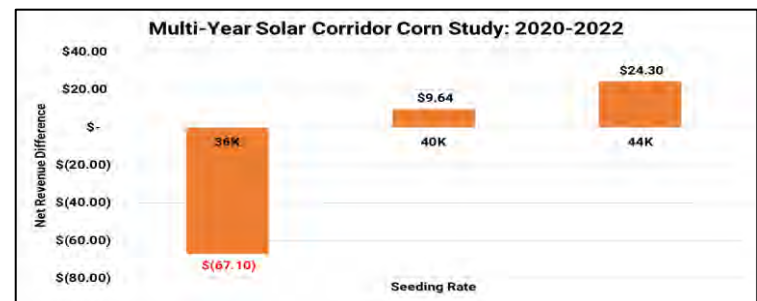
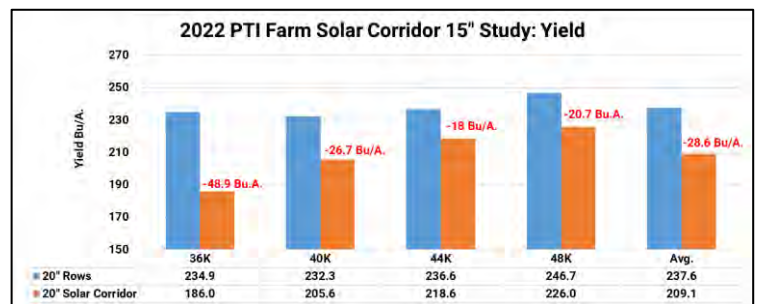

Corn Strip Planting Study

Objective: This study evaluates the yield and economic advantages of planting corn and soybeans in alternate 40' strips (Figure 1). In the past this helped to reduce erosion. The PTI team evaluated this system in 2022 to harvest more sunlight on outside rows with the intention of trying to stimulate higher corn yield. It is quite common to have higher corn yield on the outside field edges (Figure 2.), due to corn being able to harvest more sunlight. However, most often after the first few rows this yield advantage decreases due to more shading of corn biomass. This study is intended to measure any potential yield increases and the associated economics from this system.

In order to understand the agronomics of this strip cropping system, we split our trial design into four segments:

- 40' Corn Blocks (16 rows) planted in North/South rows
- 40' Corn Blocks (16 rows) planted in East/West rows
- 20' Corn Blocks (8 rows) planted in North/South rows
- 20' Corn Blocks (8 rows) planted in East/West rows

Figure 1. 40' Alternate Strips of Corn and



Figure 2. Outside Edge of Field



Corn Strip Planting Study Continued

Figure 3. 40' (16row) Alternate Strip Planting of

Figure 3 illustrates the corn strips in a 40' (16 row 30") block formation. These corn blocks were planted alternatively with 30" soybeans in both a North to South and East to West planting row to allow the ability to study the differences in sunlight shading. In corn, we also implemented the use of "shorter" stature corn being planted on the outside rows of each 40' (16 rows) blocks in an attempt to minimize shading of the soybeans from the corn.



Figure 4. 20' (8row) Alternate Strips of Corn Soybeans

Figure 4 illustrates corn strip planting in a 20' (8 row 30") block formation. This corn was also planted alternatively with 30" soybeans in both a North to South, as well as an East to West planted row to allow the ability to study the differences in sunlight shading and overall yield differences between wide and narrower corn blocks. Four corn hybrids were used to vary in height from tall to short to help minimize shading effect on the soybeans.



Corn Strip Planting Study Continued

In order to understand the agronomics of the 40' (16 row 30" blocks), we split our 16-row planter into seven individual segments to evaluate yield performance:

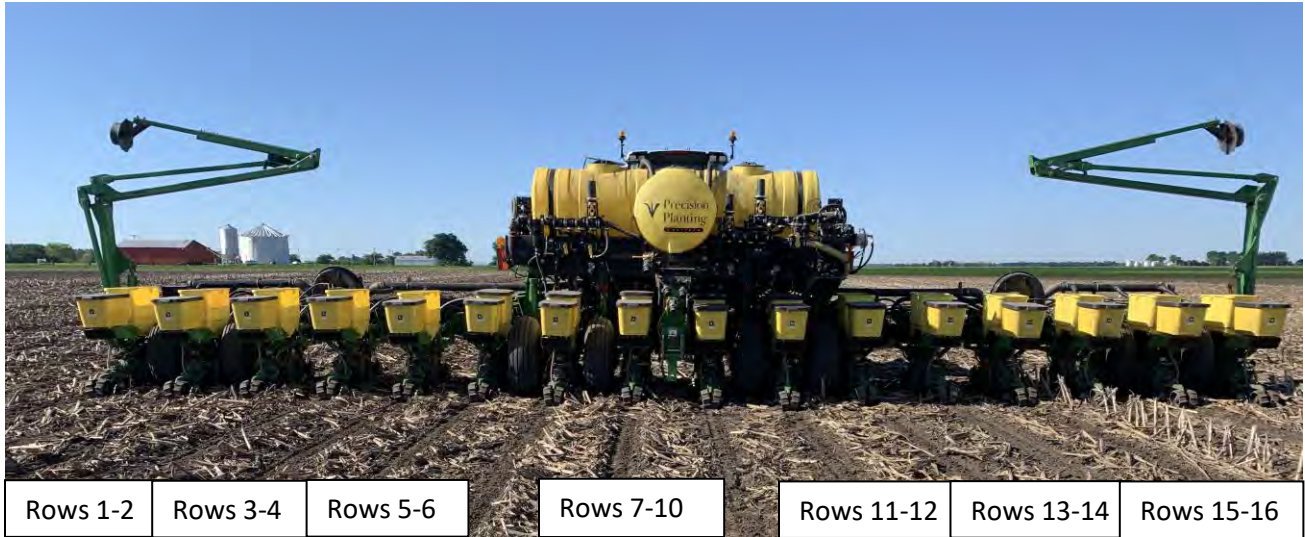

These seven individual segments were then planted in both north to south and east to west directional planting formations to evaluate the yield and economics on planter row direction.

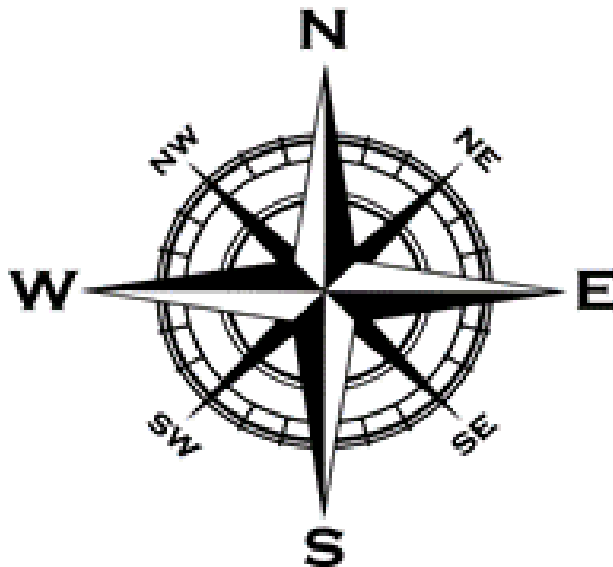

Corn Strip Planting Study Continued

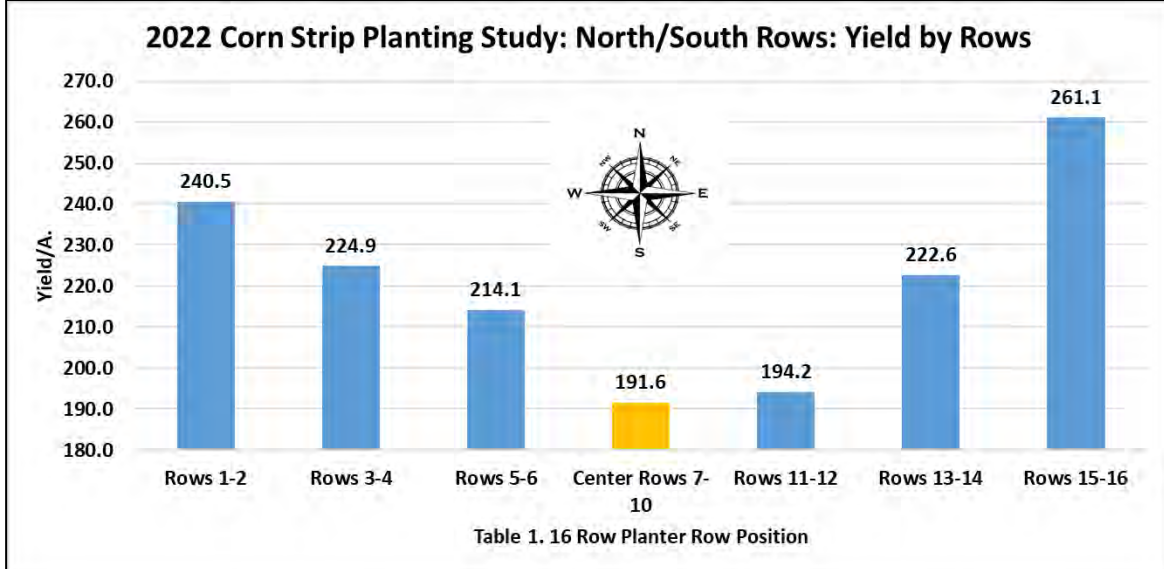

Table 1. illustrates the yield response of each planter row segment in the 40' alternate strips planted in a North/South formation. Compared to the center four planter rows, the outside two rows of the planter (rows 1-2 and 15-16) offered incredible average yield advantages of +48.9 to +69.5 Bu/A. Status quo full field planting would equate to 191.6 Bu/A. corn yield (center 4 rows), while this crop stripping experiment increased corn yield to 240.5 Bu/A. to 261.1 Bu/A. on the outside "solar corridor" two rows.

The outside two rows (1-2 and 15-16) increased revenue by +\$293.40/A. to +\$417/A. Rows 3-4 and 13-14 increased revenue by +\$186 to +\$199.80/A. and finally the inside rows 5-6 and 11-12 offered increases of only +\$15.60/A. to \$135.00/A.

Overall, North/South row strips planted in 40' (16 row) blocks offered **average** yield gains of +34.6 Bu/A. resulting in additional gains of +\$207.80/A.

Corn Strip Planting Study Continued

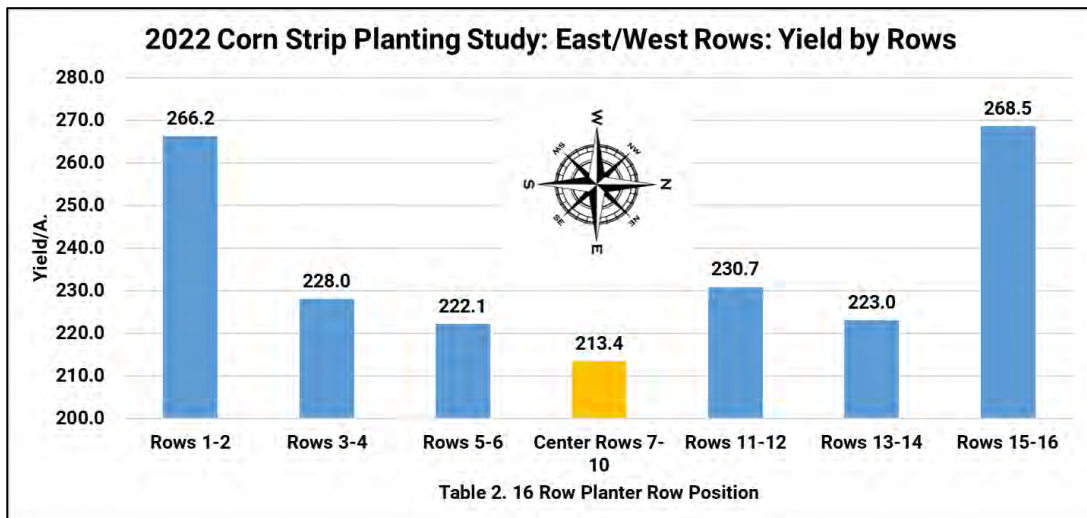

Table 2. illustrates the yield response of each planter row segment in the 40' alternate strips planted in an east/west formation. Compared to the center four planter rows, the outside two rows of the planter (rows 1-2 and 15-16) again offered incredible average yield advantages of +52.8 to +55.2 Bu/A. Status quo full field planting would equate to 213.4 Bu/A. corn yield (center 4 rows), while this crop stripping experiment increased corn yield to 266.2 Bu/A. and 268.5 Bu/A. on the outside "solar corridor" two rows.

The outside two rows (Rows 1-2 and 15-16) increased revenue from +\$316.80/A. to +\$331.20/A. Rows 3-4 and 13-14 increased revenue by +\$57.600/A. to +\$87.60/A. and finally the inside rows 5-6 and 11-12 offered increases of +\$52.20/A. to \$104.40/A.

Overall, east/west row strips planted in 40' (16 row) blocks offered **average** yield gains of +26.4 Bu/A. resulting in additional gains of +\$158.30/A.

Corn Strip Planting Study Continued

In an effort to understand corn yield in strips by block size, 20' (8 row) blocks were planted with a four-row planter. This smaller configuration allows for more "solar corridor" outside rows and reduces the 40' blocks to half the size.

Table 3. illustrates the yield response of outside versus inside rows in the 20' alternate strips planted in a north/south planting formation. Compared to the center four planter rows, the outside two rows of the planter (rows 1-2, 7-8) offered average yield advantages of +49.1 Bu/A. and +\$294.60/A. in additional revenue. Center section rows averaged 218.6 Bu/A. corn yield, while 259.1 and 276.3 Bu/A. on the outside "solar corridor" rows.

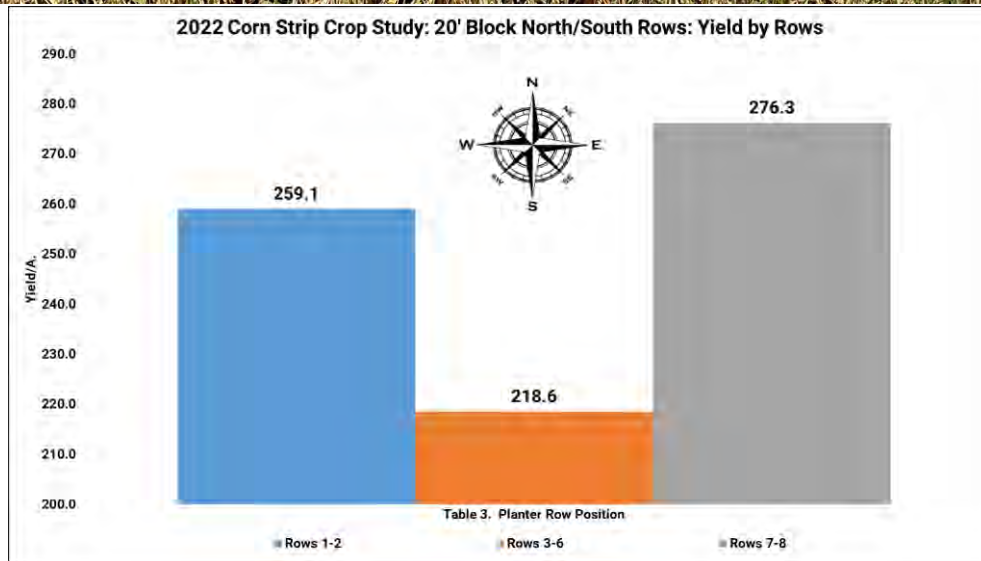

Corn Strip Planting Study Continued

Table 4. illustrates the yield response of outside versus inside rows in the 20' alternate strips planted in an east/west planting formation. Compared to the center four planter rows, the outside two rows of the planter (rows 1-2, 7-8) offered average yield advantages of +44.8 Bu/A. and +\$268.80/A. in additional revenue. Center section rows averaged 221.3Bu/A. corn yield, while 260.0 and 272.2 Bu/A. on the outside "solar corridor" rows.

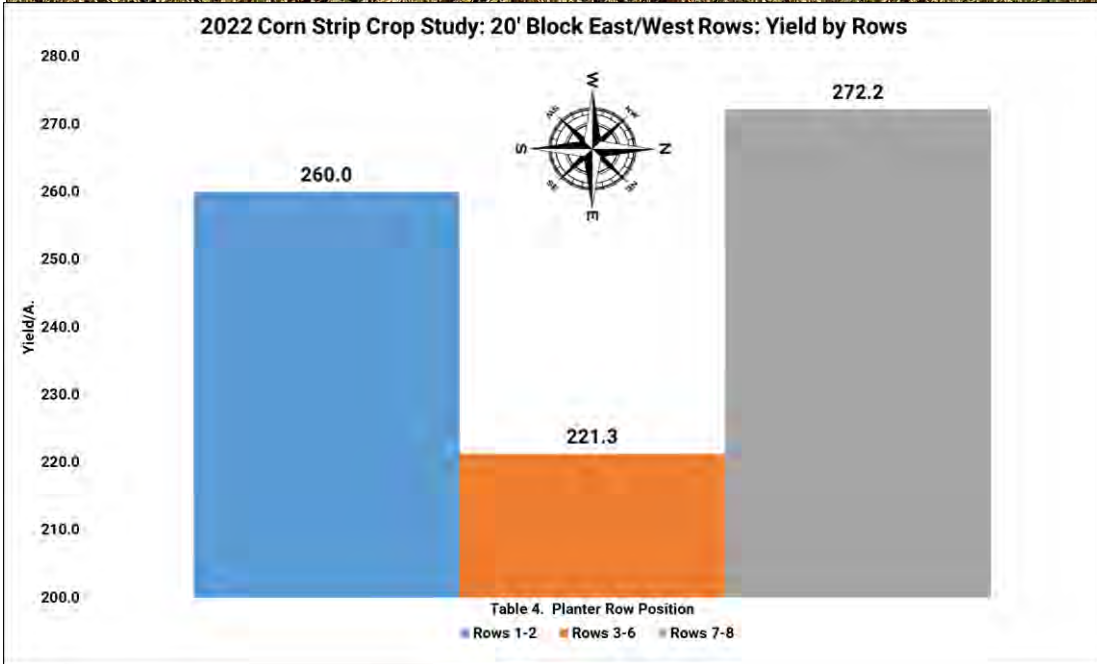

Corn Strip Planting Study Continued

2022 corn strip cropping at the PTI Farm was very successful and proved to be one of the highest overall revenue contributors on the farm. Table 5. illustrates the yield gains of strip cropping compared to a status quo traditional non-strip row-cropping practice.

40' (16row) strips resulted in overall yield gains of +26.4 to +34.6 Bu/A., with north/south rows proving +8.2 Bu/A. over east/west rows.

20' (8row) strips resulted in overall yield gains of +44.8 to +49.1 Bu/A., with north/south rows proving +4.3 Bu/A. over east/west rows.

As for economics, Table 6. reveals the overall differences in gross revenue. 40' strips resulted in gains of +\$154.55 to +\$204.05/A., while 20' strips tipped the scale at a remarkable +\$265.05 to +\$290.85/A.

At the PTI Farm, we always talk about challenging the status quo and trying to farm smarter each and every season. This strip cropping system, even though challenging to implement with herbicide/nutrient applications and general equipment sizing, proved to create some unbelievable and significant gains. We look forward to continuing testing this system in the future.

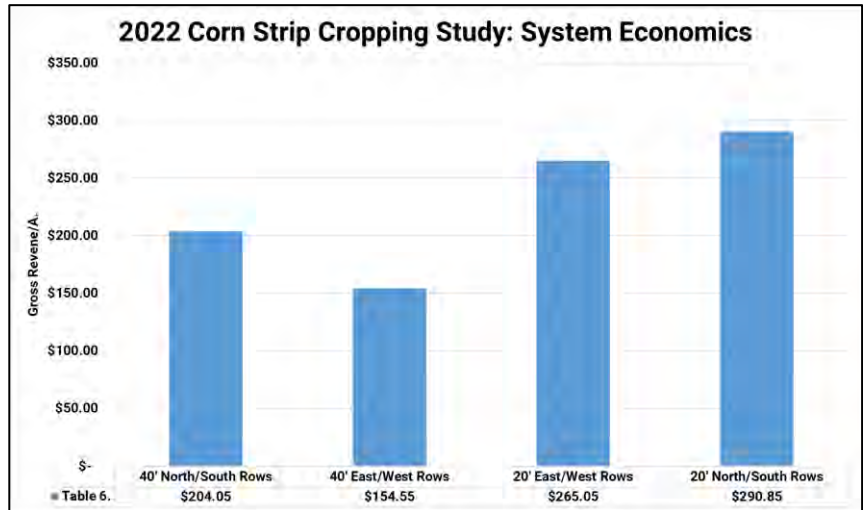
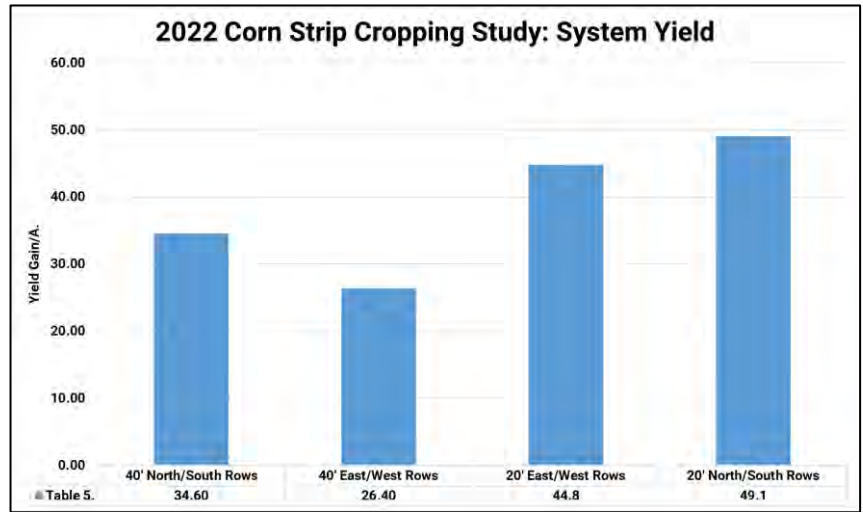

Corn Topguard®EQ Foliar Fungicide Study

Objective: To evaluate the yield and net return of Topguard® fungicide. Topguard® contains flutriafol, which is a Group 3 highly systemic fungicide with translaminar activity that protects the sprayed leaf throughout growing season to help prevent additional disease from developing.

Topguard® fungicide provides long lasting residual protection in corn and protects against key diseases including anthracnose, cercospera leaf blight, frog-eye leaf spot, rusts, leaf blights, powdery mildew and tar spot.

Results: Table 1 illustrates that TopGuard® EQ foliar applications of Topguard® resulted in average yield gains of +7.9 Bu/A to +13.0 Bu/A.

Table 2. reveals economics of all treatments. After cost of application and fungicide, using a \$6.00 corn price, Topguard® EQ proved highest positive net returns at a single VT application at +\$27.60/A. Stand-alone V10 performed **-\$10.20/A.** less than VT treatments.

Sequential V10/VT treatments resulted in losses of **-\$21.60/A.**, while VT/R3 at **-\$9.60/A.** compared to single VT treatments.

FLUTRIAFOL	Group	3	Fungicide
AZOXYSTROBIN	Group	11	Fungicide



TOPGUARD® EQ FUNGICIDE

For use on almond, barley, brassica leafy vegetables crop group 5, celery and Chinese celery, corn, cotton, cucurbit vegetables, grain sorghum, grapes, leafy vegetables, except brassica, crop group 4, peanuts, pecan, soybeans, stone fruit, strawberry, sugar beets, tomatoes, tree nuts, vegetable, fruiting, group 8-10, wheat, and triticale.

EPA Reg. No. 279-3596 EPA Est. No. 82978-FRA-001

ACTIVE INGREDIENTS: **By Weight**

Azoxystrobin: methyl (E)-2-[2-[6-(2-cyanophenoxy) pyrimidin-4-yloxy]phenyl]-3-methoxyacrylate* 25.30%

Flutriafol 18.63%

OTHER INGREDIENTS: 56.07%

TOTAL: 100.00%

Contains 1.82 lb. of flutriafol and 2.47 lb. of azoxystrobin active ingredient per gallon. Suspension Concentrate. *IUPAC

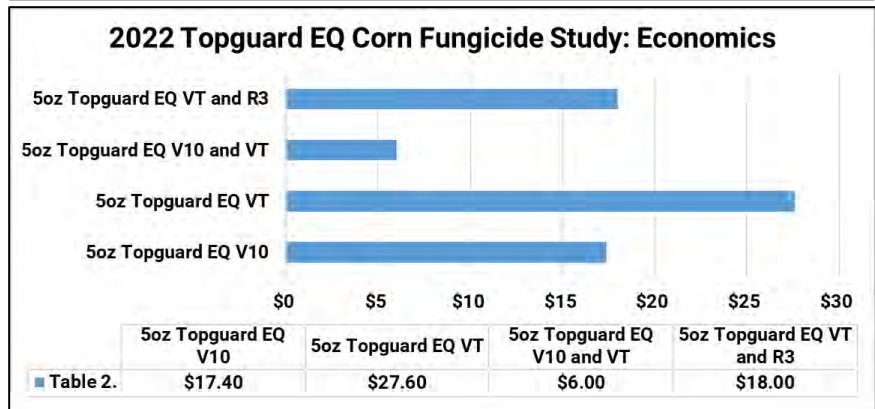
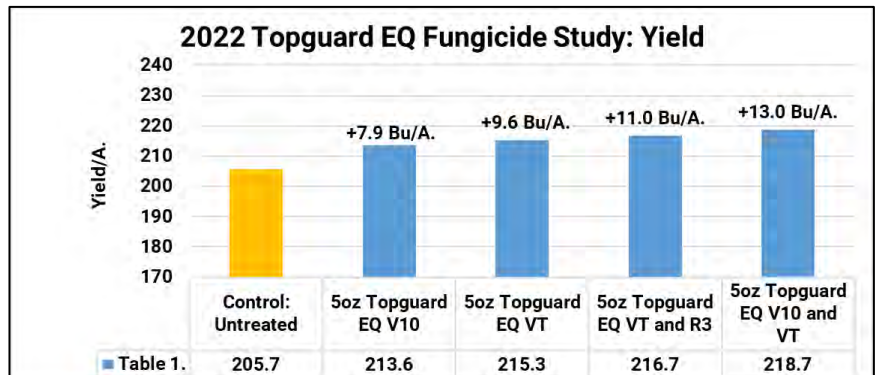

Miravis® Neo Corn Foliar Fungicide Study

Objective: To evaluate the yield and economics of a Miravis®Neo fungicide.

Miravis®Neo fungicide combines propiconazole, azoxystrobin and Adepidyn technology – one of the most powerful, broad spectrum SDHI molecules available, and delivers superior plant-health benefits and improved preventive and curative control of key diseases such as Gray Leaf Spot, Common and Southern Rust, Tar Spot, Eye Spot, Anthracnose, Diplodia Ear Rot, and Physoderma Brown Spot.

Results: Miravis®Neo treatments at VT growth stage proved yield gains of +8.8 Bu/A. with positive economic returns of +\$25.81/A.

A sequential treatment again at R1, proved additional yield gains of +3.0 Bu/A. but offered **-\$8.99/A** negative return on investment over single VT treatments.



ADEPIDYN® Technology*

Active Ingredients:

Pydiflumetofen**	PYDIFLUMETOFEN	GROUP 7	FUNGICIDE	7.0%
Azoxystrobin***	PROPICONAZOLE	GROUP 3	FUNGICIDE	9.3%
Propiconazole****	AZOXYSTROBIN	GROUP 11	FUNGICIDE	11.6%

Other Ingredients:	72.1%
Total:	100.0%

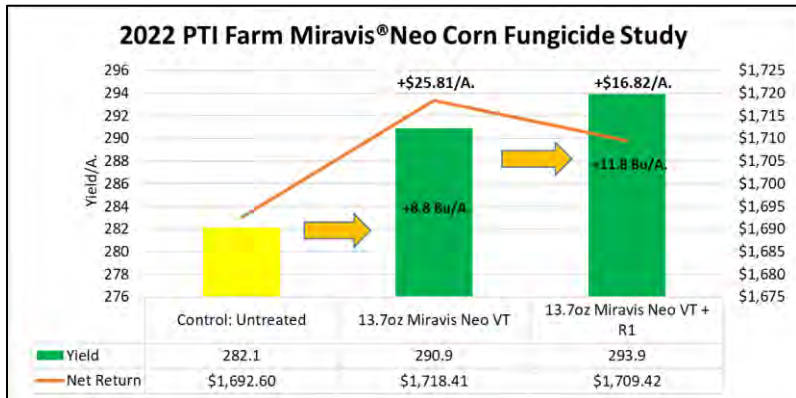

Fungicide Ground vs. UAV Foliar Spray Application Study

Objective: To evaluate the yield and net return of Trivapro® fungicide applied at VT growth stage.

This study evaluates a traditional ground fungicide application with a Hagie® high-clearance sprayer, at a carrier rate of 15 Gal/A. Additionally, the use of a Rantizo® MG-1P spray UAV was also evaluated at carrier rates of 3 Gal/A. (Figure 1).

Trivapro® fungicide is a fungicide for corn, soybeans, and wheat. It contains three robust active ingredients including Solatenol® fungicide, azoxystrobin and propiconazole. Trivapro® is a fungicide product that offers both preventive and curative disease control.



SOLATENOL® Technology*

*Technology denotes the active ingredient, Benzovindiflupyr.

Active Ingredients:

Benzovindiflupyr**..... 2.9%

Azoxystrobin***..... 10.5%

Propiconazole****..... 11.9%

Other Ingredients:..... 74.7%

Total:..... 100.0%



Figure 1. Hagie® Ground Sprayer and Rantizo® MG-1P Spray UAV



Figure 2. Tar Spot in Corn

Fungicide Ground vs. UAV Spray Application Study Continued

Results: Table 1. illustrates that VT foliar applications of Trivapro® resulted in yield gains of +11.7 to +13.0 Bu/A., with the Hagie® high clearance sprayer and the Rantizo® Spray UAV yielding within 1.3 Bu/A. of each other.

Table 1. also reflects the difference in yield and return on investment by application type. As a new technology in the marketplace, the Rantizo spray UAV did in fact offer similar yield compared to ground application by +1.3 Bu/A. After cost of application and fungicide, using a \$6.00 corn price, Rantizo spray UAV applications proved positive net returns of +\$7.20A. compared to traditional ground application. In our 2nd year of evaluating spray UAV applications, it does appear that this technology is an effective method to apply crop protection products. In 2021, the spray UAV applications resulted in +4.5 Bu/A. yield gains with additional revenue of +\$22.50/A.

Advantages to this technology include precise application due to downward propeller air movement, low carrier rates, the absence of ground or soil engagement, and the ability to spray in fields with topography challenges. Disadvantages include flight time duration and overall extra time it takes with spray UAV technology versus large commercial sprayers that are more efficient.

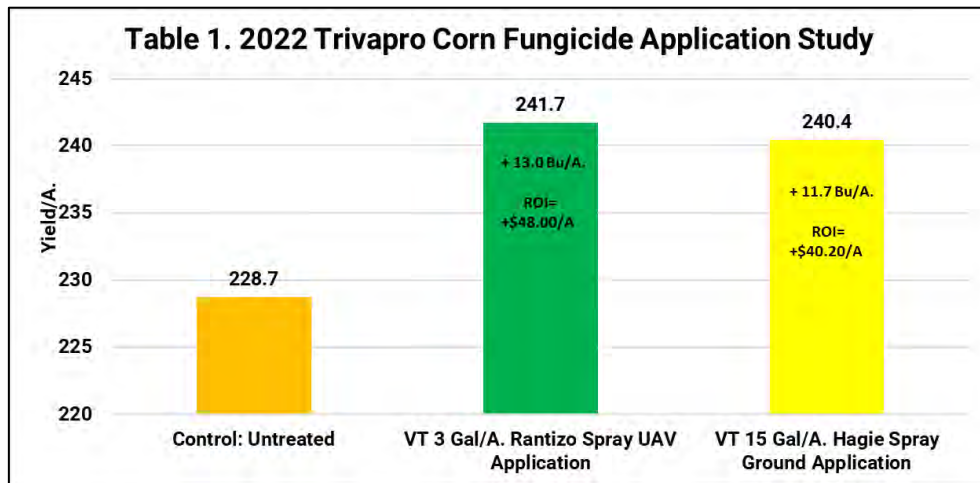

Figure 3. Rantizo MG -1P UAV

QLF™ L-CBF Amino 15™ Foliar Study

Objective: To evaluate yield and net return of QLF™ Agronomy’s Liquid Carbon-Based Fertilizer (L-CBF) Amino 15-0-1 applied at 5 Gal/A. foliar at the VT growth stage.

Amino 15-0-1 is a balanced source of foliar nitrogen with available carbon in a low pH chemistry package. L-CBF Amino 15-0-1 has 10% sugar. For every gallon, a full pound of sugar is delivered in a microscopic form, raw and undegraded, further enhancing the adjuvant characteristics of this liquid fertilizer blend.

Derived from sugar cane molasses with an added fermentation yeast extract for enhanced biological function and paired with high quality Urea solution and L-Amino Acid forms of nitrogen, L-CBF

Amino 15-0-1 is a safer and more efficient approach to foliar nitrogen applications and plant protein formation.

Results: 5 Gal./A. of Amino-15 proved positive yields of +10.3 Bu./A. with a positive return on investment of +\$37.55/A.

2021 data proved +9.4 Bu/A. gains and returns of +\$28.40/A.

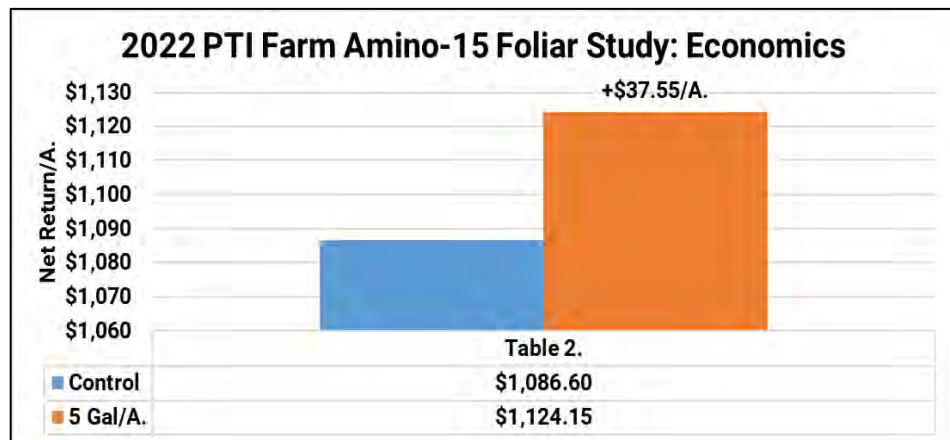
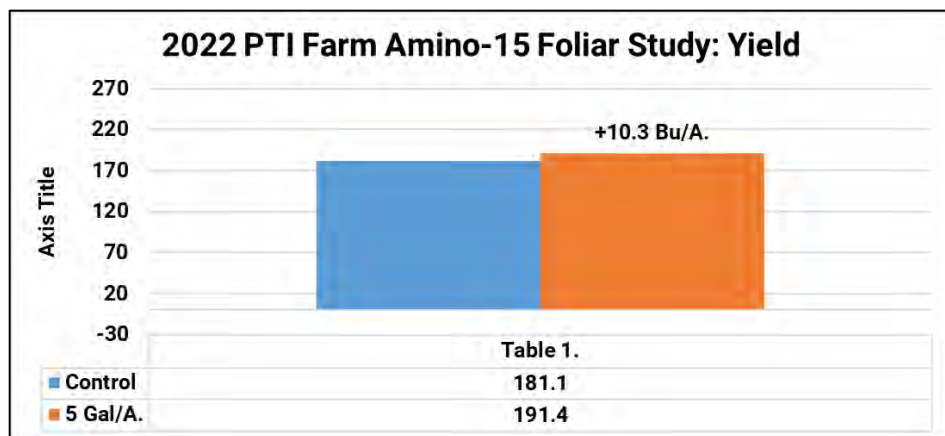

Aqua-Yield® NanoK® Foliar Potassium Study

Objective: To evaluate yield and economics of NanoK® by AQUA-YIELD. NanoK® delivers potassium acetate through Aqua-Yield nanoliquid technology. Potassium is a vital nutrient for plant growth, and NanoK® ensures a strong plant structure resulting in enhanced crop quality and yield. NanoK also decreases drought stress and boosts the plant’s immune system to fight off disease.

This trial aims to establish the efficiency of Aqua-Yield’s NanoK® as a foliar based application of 4oz/A. at the V5 growth stage.

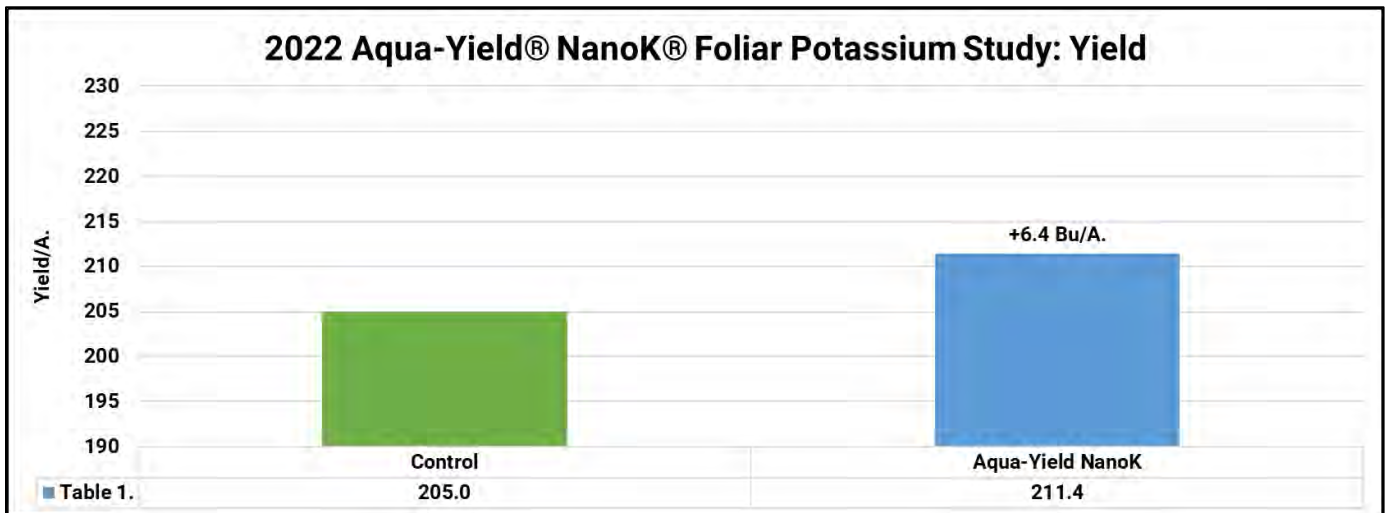

AQUA-YIELD®

NanoK®

Aqua-Yield® NanoK® Foliar Potassium Study Continued

Results: Table 1. illustrates yield results of all treatments. Aqua-Yield’s NanoK® resulted in +6.4 Bu/A. yield improvement over the control.

Table 2. summarizes the overall economics of the foliar fertility study where NanoK® resulted in positive economic gains of +\$31.34/A.

Figure 1. below is a recent soil test from the PTI Farm. Base saturation K levels indicate low levels of 2.0 to 2.8%, when nearer to 4% would be optimum. This may help explain as to the reason for the nice response of NanoK®. Potassium continues to be a concern and goal/challenge to correct at the PTI Farm.

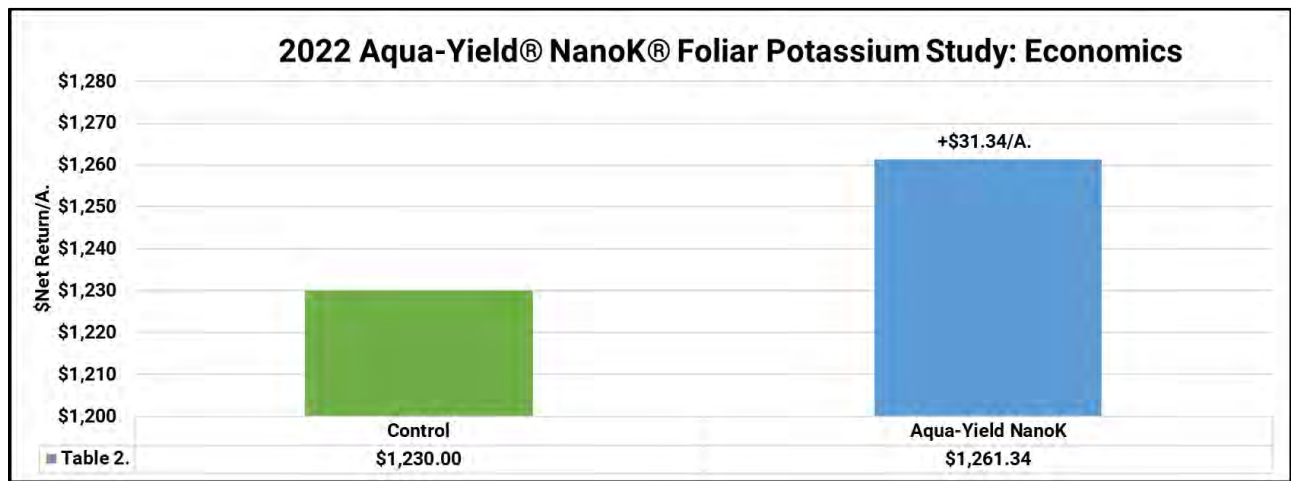

SOIL ANALYSIS REPORT																			
ORGANIC MATTER L.O.I.	PHOSPHORUS			NEUTRAL AMMONIUM ACETATE (EXCHANGEABLE)				pH		CATION EXCHANGE CAPACITY C.E.C. meq/100g	PERCENT BASE SATURATION (COMPUTED)								
	P ₁ (WEAK BRAY) 1:7	P ₂ (STRONG BRAY) 1:7	OLSEN BICARBONATE P	K		Mg		Ca			Na		% K	% Mg	% Ca	% H	% Na		
	percent	RATE	ppm	RATE	ppm	RATE	ppm	RATE	ppm		RATE	ppm	RATE	SOIL pH 1:1	BUFFER INDEX	meq/100g	%	%	%
4.9 VH	35 VH	66 VH		228 M		601 VH		4179 H		10		6.3	6.6	29.6	2.0	16.9	70.6	10.4	0.1
3.5 M	33 VH	54 H		168 M		309 VH		3008 H		9		6.1	6.6	21.0	2.1	12.3	71.6	13.8	0.2
4.1 H	38 VH	68 VH		258 VH		372 VH		3528 H		9		6.3	6.7	23.9	2.8	13.0	73.8	10.2	0.2

Figure 1: Soil Test Results at PTI Farm

Planting Date: May 11th Hybrid: GH 15J91 Population: 36K Row Width: 30" Rotation: CAB Corn Price: \$6.00 NanoK®: \$7.06/A.

Aqua-Yield® NanoPro® Foliar Fungicide Study

Objective: To evaluate yield and economics of NanoPro® by AQUA-YIELD. NanoPro® is a carrier adjuvant that enhances the uptake of crop protection products.

This trial aims to establish the efficiency of Aqua-Yield’s NanoPro® as a tank-mix partner with a corn fungicide applied at the VT growth stage (13.7oz/A. Miravis® Neo).

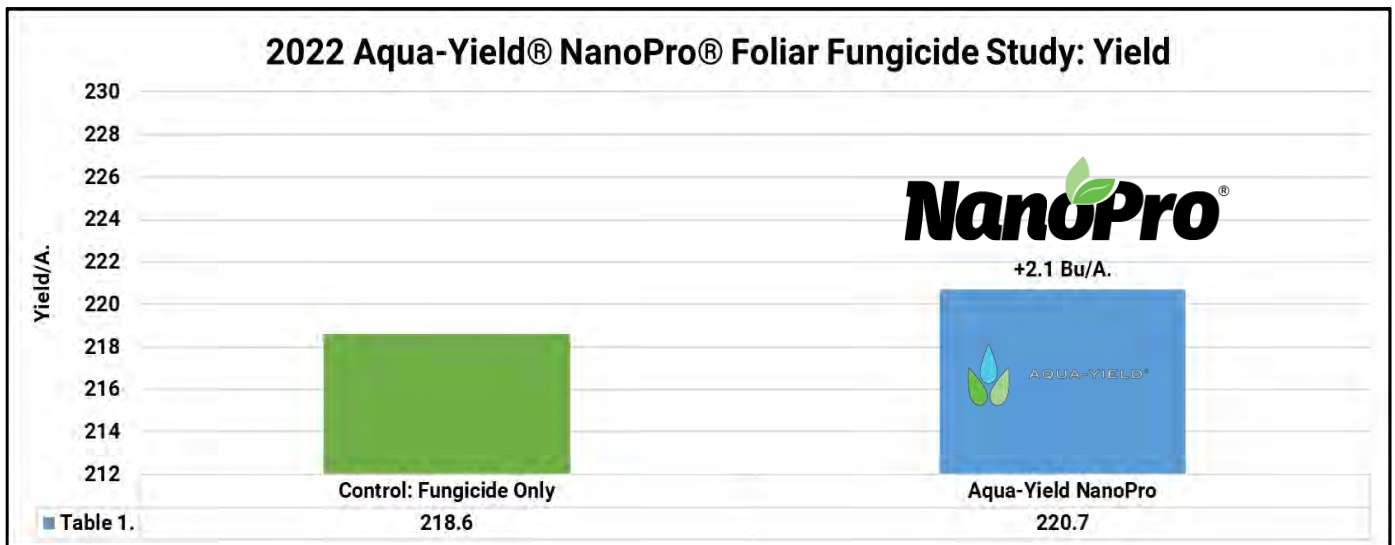

Results: Table 1. illustrates Aqua-Yield’s NanoPro® resulted in +2.1 Bu/A. yield improvement over the control of a standard fungicide application at VT growth stage.

With a +2.1 Bu/A. yield response, economics would suggest that NanoPro® resulted in positive economic gains of +\$9.69/A.

Chopping Corn Head Study

Objective: To study the yield impact of utilizing a chopping corn head in a continuous corn conventional tillage rotation. A Capello Quasar™ chopping head is used to create replicated strips of chop and non-chop residue management trials. The goal of this trial is to evaluate sizing of residue, allowing heavy stalks and residue to break down faster to advance the degradation process and in turn, reducing the carbon penalty associated with continuous corn environment.

Results: Table 1. illustrates that chopping corn residue improved corn yields by +6.5 Bu/A. and increased gross revenue by +\$39.00/A. at a corn commodity price of \$6.00/Bu.

Multi-year data from 2017-2022 indicates consistent results with chopping advantages of +6.5 to +11.1 Bu/A.

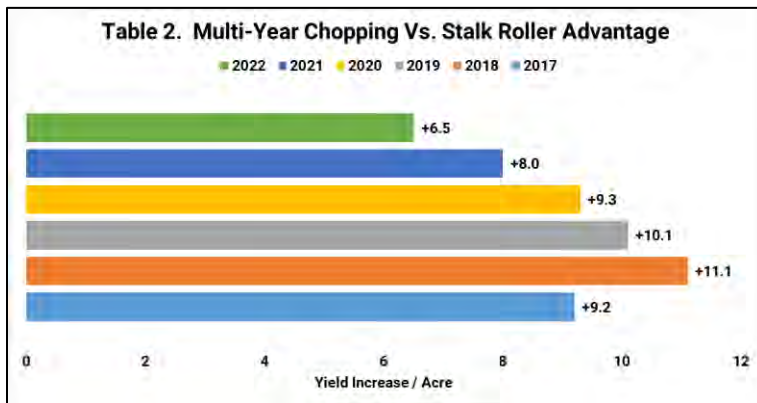
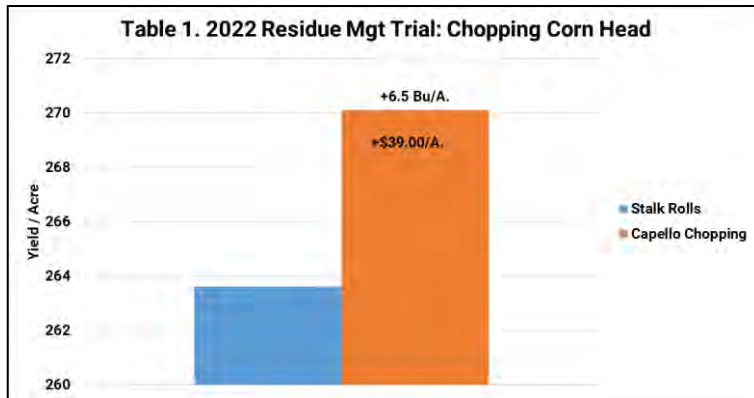

Corn Tillage Study

Objective: To evaluate the yield and economic impacts of various tillage programs in a corn after soybean rotation. Tillage programs include conventional till, strip-till, vertical till, no-till and in-line rip.

Figure 1. Sunflower® 6833 Vertical Tillage



Figure 2. KUHN® Krause® Gladiator®



Tillage Practice	Category	Cost
Conventional Till	Disk Ripper	\$ 27.70
	Soil Finisher	\$ 13.60
	Plant	\$ 17.20
	Total:	\$ 58.50
Strip Till	Strip	\$ 17.30
	Burndown	\$ 8.00
	Plant	\$ 17.20
	Total:	\$ 42.50
Vertical Till	Vertical	\$ 13.20
	Burndown	\$ 8.00
	Plant	\$ 17.20
	Total:	\$ 38.40
No Till	Burndown	\$ 8.00
	Plant	\$ 19.00
	Total:	\$ 27.00
In-Line Ripper	V-ripper	\$ 23.40
	Soil Finisher	\$ 13.60
	Plant	\$ 19.00
	Total	\$ 56.00

Figure 3. Sunflower® 4630 Disc Ripper



Figure 4. Planting in No-Till



Figure 5. Sunflower® 4608 In-Line Ripper



Figure 6. Univ. of IL Machinery Cost Estimates

Corn Tillage Study Continued

Results: To understand both yield and economics, the University of Illinois Machinery Cost Estimate Summary is used to calculate individual cost of each tillage program (Figure 6). For the three reduced tillage programs, an \$8/A. burn-down is also included.

Table 1. illustrates the overall yield for each tillage segment. Yield varied only **-4.7 Bu/A.** between all tillage programs. This is the first year at the PTI Farm where all tillage yield ended at par. Strip-till offered highest yields at 267.4 Bu/A., while conventional till the lowest at 262.7 Bu/A. This may be contributed to the unusual hot and dry June experienced this spring burning high amounts of soil moisture.

After applying all appropriate costs to each individual tillage segment, no-till offered the highest overall revenue in this tillage system study in 2022. This is interesting, as it's the first time no-till has won. The PTI Farm had been in conventional tillage for decades and this data may indicate that at least 5 years may be needed for no-till to setup high yield. Compared to no-till, strip-till offered losses of **-\$3.50/A.**, vertical tillage **-\$6.60/A.**, in-line ripping losses of **-\$28.40/A.** and finally conventional tillage at **-\$47.70/A.** (Table 2).

Table 3. illustrates multi-year data from the PTI Farm in 2018-2022. Strip-till over this time frame has provided the highest overall net returns, with conventional till behind by **-\$18.41/A.** Vertical and no-till have resulted in losses of **-\$23.71** and **-\$29.10/A.** respectively.

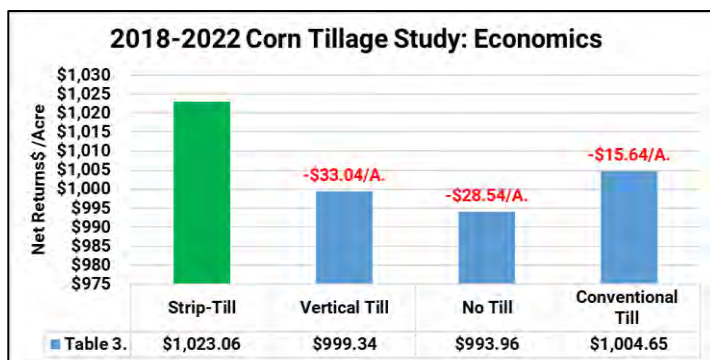
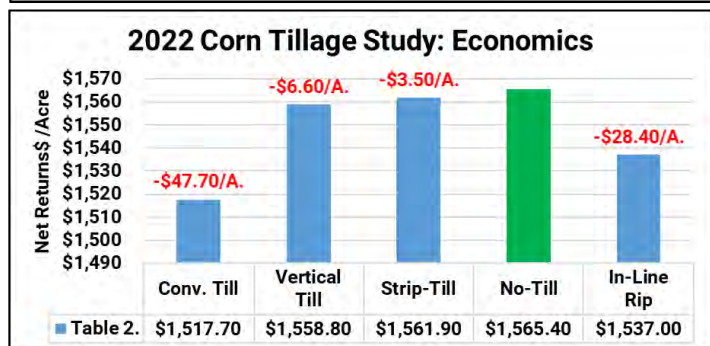
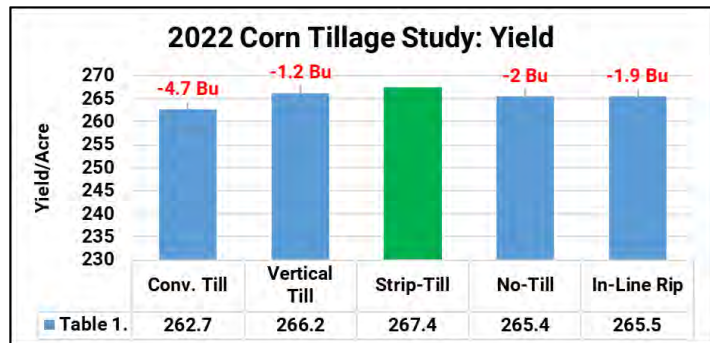

Yetter Strip Freshener™ Study

Objective: To evaluate Yetter 2984 strip fresheners to facilitate consistent soil warming and bring existing strips to life. Original fall strips made in October after harvest were freshened in April before planting (Figure 1).

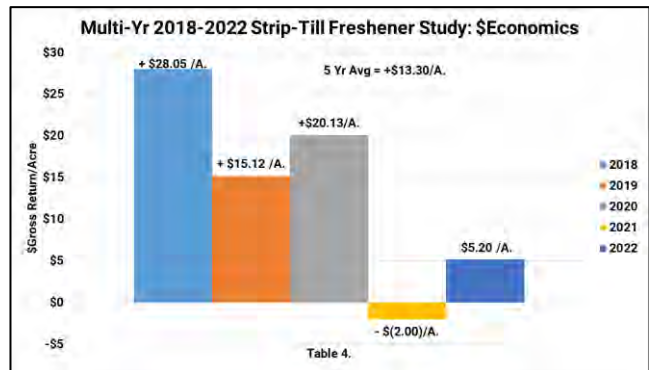
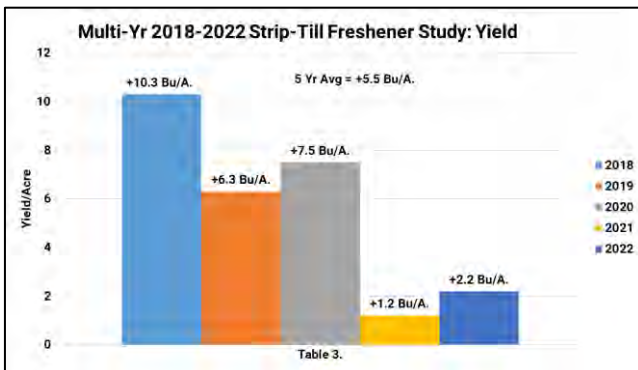
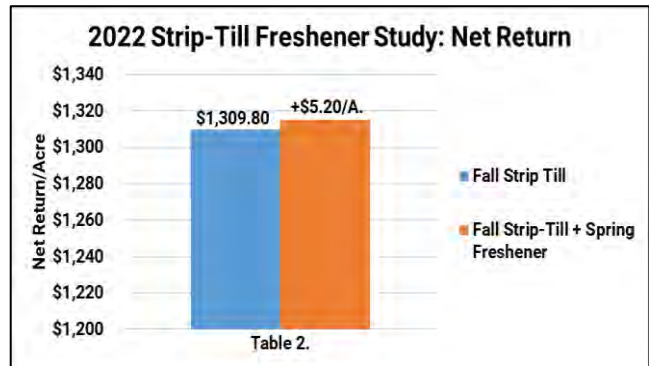
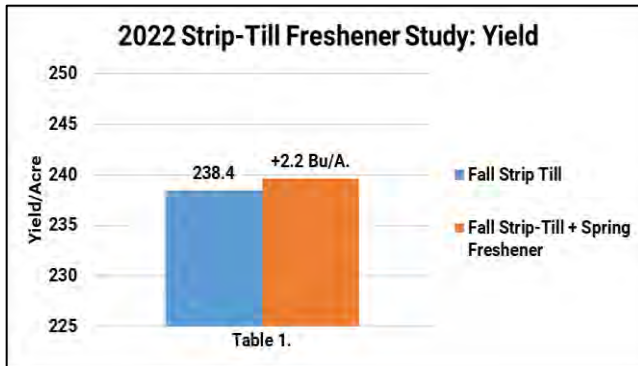

Figure 1. Yetter 2984 Strip Freshener

Features:

- 3-blade arrangement with rolling basket to condition strips
- Operates at 6 to 10 mph and 1 1/2" to 4" deep, depending on depth setting
- Precision Planting CleanSweep® residue managers to clean rows while building strip

Results: Spring strip freshening increased yield by an average of +2.2 Bu/A. and resulted in economic gains of +\$5.20/A., using a custom cost of \$8/A. for calculating charge of application (Tables 1-2.) Tables 3-4. illustrate multi-year 2018-2022 average yield gains of +5.5 Bu/A. with net positive economic gains of +\$13.30/A. Only one year in five were net losses associated from freshening strips.



Soybean Table of Contents:

Soybean Planting Principles:

Planting Date	163
Starter Fertilizer Response by Date	164-165
Multi-Year Early Plant Date	166
Reveal™ Residue Management	167-168
CleanSweep® Residue Management	169-170
Downforce Management	171-173
Keeton® Seed Firmer	174
FurrowJet® Side-Wall	175
Singulation	176
Closing Wheels	177-179
FurrowForce® Auto vs Manual Control	180
Frost	192-195
STP Opening Discs	196-197
Strip Planting	198-205
Row Width & Seeding Rate	206-208
Early Planted Seeding Rate	209-210
High Speed	211
Air Seeder	212-213
Rolling	214-215
Planting Depth	248

Soybean Fertility & Pest Management:

Calcium Products 98G™	191
Cover Crop Study	216-217
Broadcast vs Banding	218-219
Broadcast vs Banding Rate Efficiency	220-221
Marco Quick Grow LTE FurrowJet®	222
Marco BioMarc FurrowJet®	223
Nachurs® Start2Finish	224
AgroLiquid® Starter Fertilizer	225
Stoller®USA FurrowJet®	226-227
QLF L-CBF Amino 15-0-1 Foliar	228
QLF L-CBF 5-5-5-1S Study	229
Stoller®USA V2 Foliar Application	233-234
Stoller®USA R3 Foliar Application	235-236
Revytek™ Foliar Fungicide	237
Miravis Neo™ Foliar Fungicide	238
Calcium Products SO4™	239
Marco Fertilizer Conceal® 14-12-4-6s	240
Nachurs® Conceal® K-Fuse® Potassium	241
L-CBF 7-21-3 MKP FurrowJet®	242
L-CBF Boost 4-0-3-2S Conceal	243

Soybean Tillage:

Soybean Tillage	245-247
-----------------	---------

Soybean Intensive Management:

High Yield Study: West	181-183
At-Plant Nutritional Study	184-185
Yield to Seeding Rate Ratio	186
Irrigation Study	187
Soybean Seed Size	188
High Yield Study: East	189-190
High Management Ocean Blue Ag	230-232

Soybean Planting Date Study

Objective: To evaluate various soybean planting dates throughout the spring to determine optimum planting date. Once optimum yield is discovered, data can then be analyzed to determine the deviation of yield at both early and late planting dates compared to traditional norms. With the recent trend of earlier soybean planting dates achieving higher yields, it is our intention to plant as early as possible in this study and plant every week throughout the spring planting season when fit.

Results: Table 1. illustrates the results of five planting dates over March 17th, April 26th, May 18th, May 27th, and June 6th. Optimum planting date occurred on April 26th, receiving the highest yield of 82.0 Bu/A.

Early March 17th plantings falls short by **-8.3 Bu/A.**, while May 18th and May 27th only **-1.2** to **-2.2 Bu/A.** June 6th plantings saw the most significant yield decrease by **-23.8 Bu/A.** at 58.2 Bu/A.

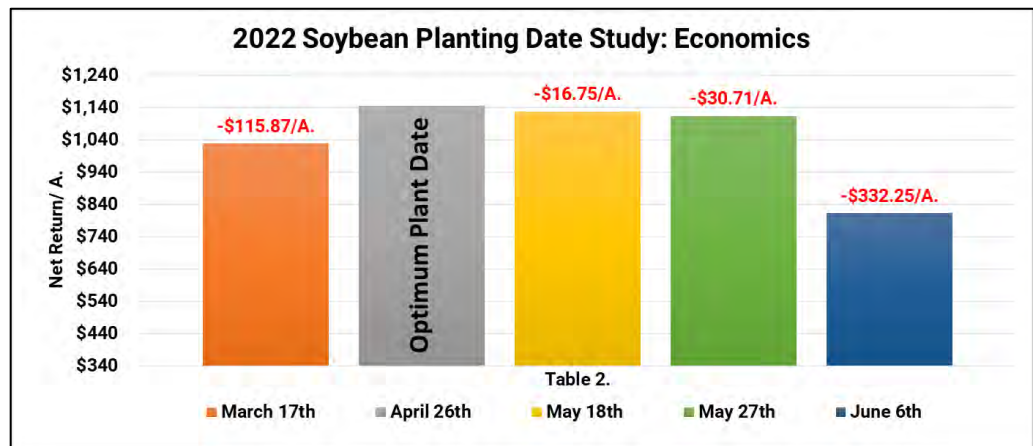
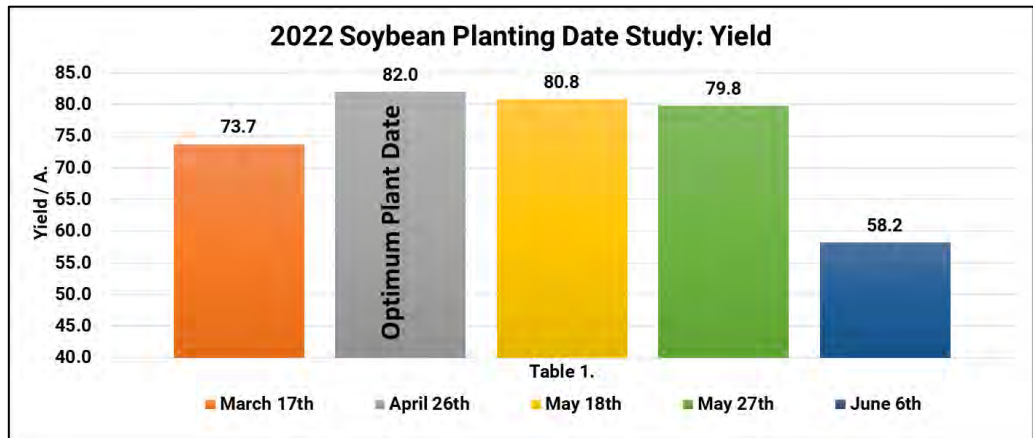

Table 2. illustrates the overall economic implications from deviating from optimum planting date and reveals net economic losses of **-\$115.87/A.** on the early planting date to only **-\$16.75** to **-\$30.71/A.** on the May 18th and May 27th planting date. June 6th planting dates ended up costing large losses of **-\$332.25/A.**

Multi-Year Early Plant Date Soybean Study:

Objective: To evaluate the yield and economics of early planted soybeans compared to traditional later soybean plant dates. Pushing planting dates earlier; extends the growing season, leading to earlier flowering dates, and overall higher yield potential.

Results: The table below illustrates multi-year early planted soybean data from the PTI Farm. Traditionally, planting dates during the first week of May is very common for soybeans. However, multi-year data from 2018-2022 has proven earlier planting can result in significant yield increases.



Ultra-early planting dates in March, have accomplished +18.1 Bu/A. yield gains compared to that of traditional planting dates in the first week of May. As planting dates were made in either the first half or second half of April, yield gains of +14.2 Bu/A. to +15.1 Bu/A. were observed.

In general, PTI data suggests that if a grower is capable of moving planting dates earlier, increased yield is obtainable if managed correctly.

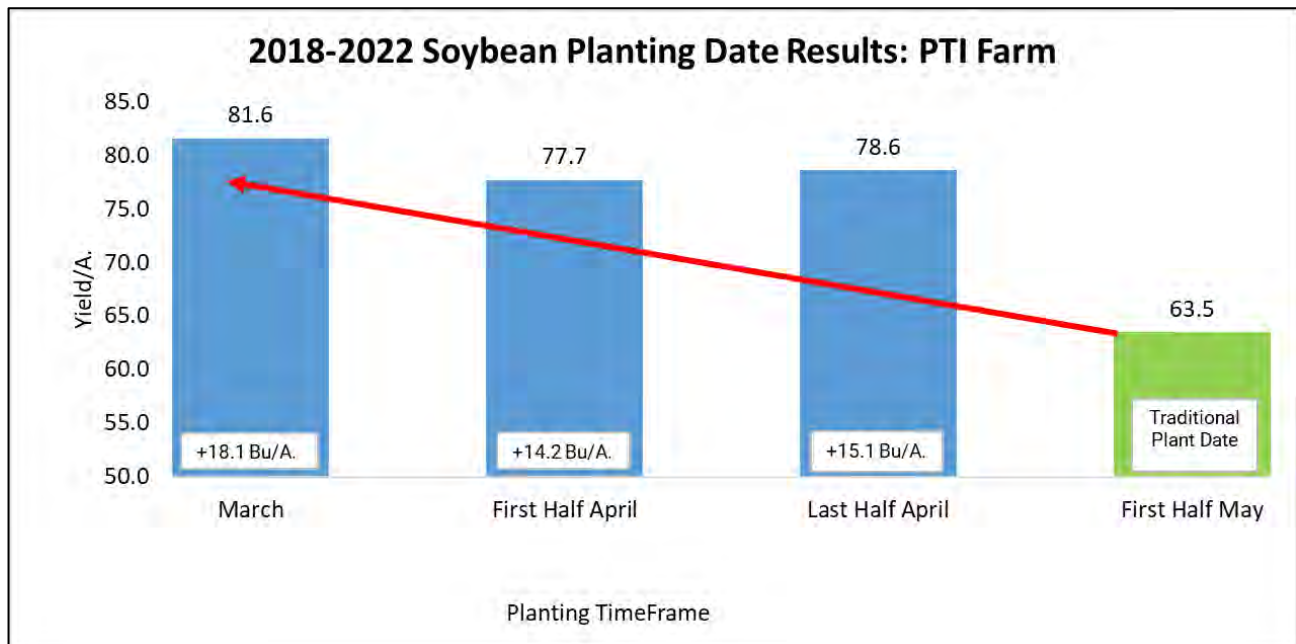

Soybean Early Plant Maturity Study

Objective: With the recent trend of earlier soybean planting dates achieving higher yields, it poses the question “If I plant soybeans early, should I plant an earlier or later maturing soybean?” This study evaluates the difference in yield on a group 2.9 and 3.9 maturity soybean planted on March 17th and April 26th.

Results: Table 1. illustrates the 3.9 maturity soybean outperformed the earlier 2.9 by **-1.0** on the March 17th planting and **-4.3 Bu/A.** on the April 26th plant dates, with economic losses of **-\$13.96/A.** and **-\$60.03/A.**

As a 1st year study in 2022, we plan to continue evaluating this on an annual basis going forward to help understand more regarding soybean maturity by planting date.

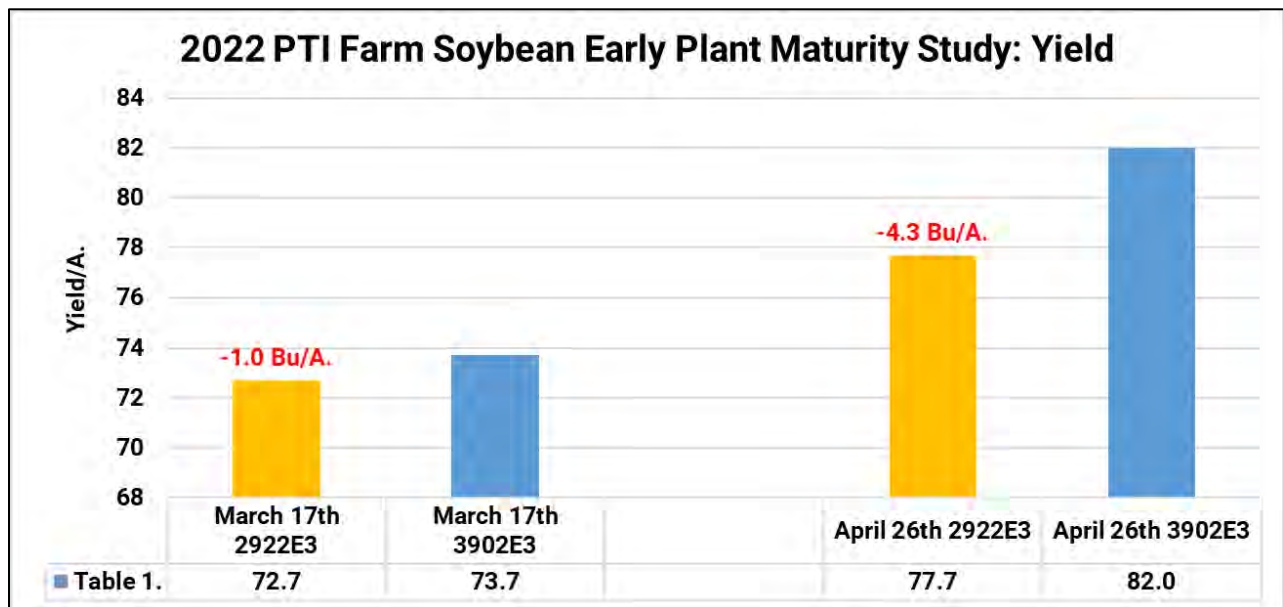

Soybean Starter Fertilizer Response by Planting Date Study

Objective: To monitor the performance of starter fertilizer at various planting dates. When does starter fertilizer give the highest returns? Does starter fertilizer respond differently at earlier planted dates versus later? In this study we evaluate six planting dates consisting of March 17th, April 26th, May 18th, May 27th, and June 6th with and without a starter fertilizer, monitoring its performance throughout the planting season.

The starter fertilizer program used for this study consists of the following:

<u>Product</u>	<u>Fertilizer Analysis</u>	<u>Placement of Fertilizer</u>
1 Gal/A. Triple Option®	4-13-17-1S	FurrowJet® Center
2 Gal/A. Triple Option®	4-13-17-1S	FurrowJet® Wings
3 Gal/A. K-Fuse®	6-0-12-12	Conceal®
5 Gal/A. Nachurs Throwback®	9-27-4-4	Conceal®



Figure 1. FurrowJet® Placement



Figure 2. Conceal Placement

Soybean Starter Fertilizer Response by Planting Date Study Continued

Results: Table 1. illustrates all starter fertilizer treatments offered minimal yield gains at each of the three planting dates. Yield gains averaged only +1.4 Bu/A., ranging from +0.7 to +2.2 Bu/A. between all the planting dates. 2022 starter fertilizer treatments offered the highest yield gains in the early March 17th and April 26th plantings with average yield gains of +1.3 to +2.2 Bu/A. As planting dates progressed later on May 18th, yield gains fell to only +0.7 Bu/A.

Table 2. focuses on net return on investment and illustrates that all starter fertilizer treatments realized net losses ranging from **-\$20.29/A.** to **-\$41.23/A.**

Increased fertilizer cost +37.5 to +48.2% in 2022 and the lack of significant yield response both contributed to net losses from applied starter fertilizer.

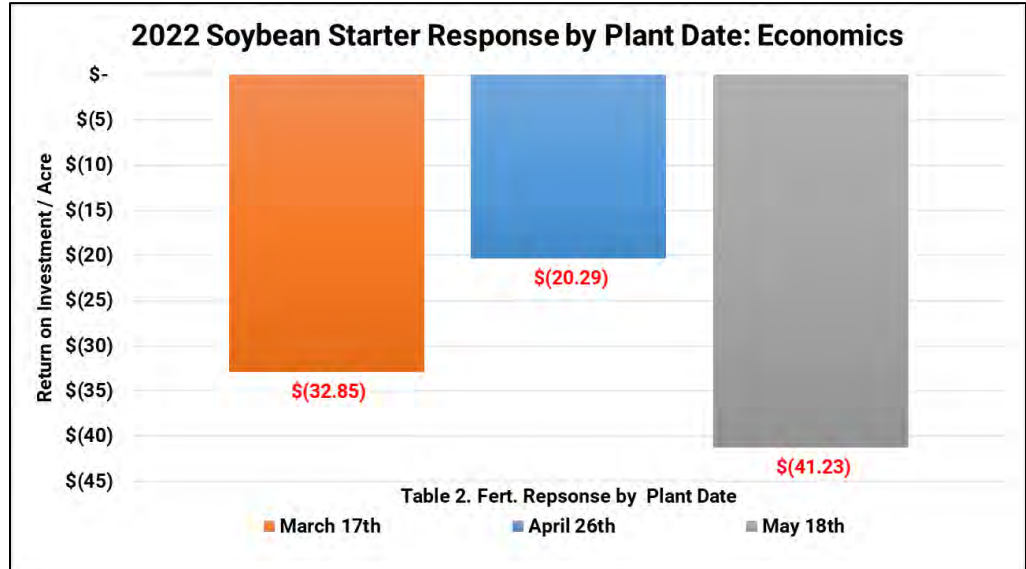
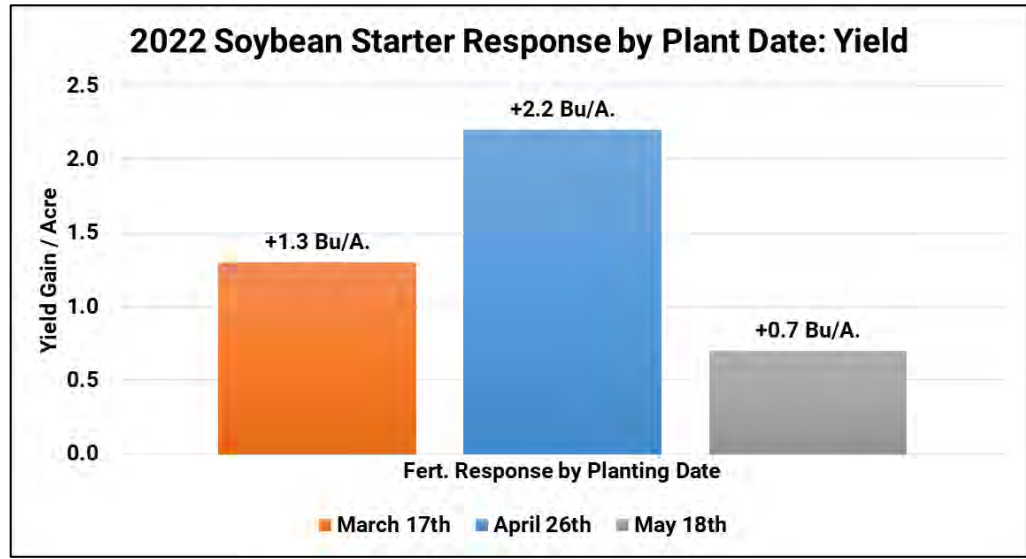

Planting Date: Varied Variety: GH3582Enlist Population: 130K Row Width: 30" Rotation: BAC SB Price: \$13.96
 K-fuse®: \$6.60/Gal Nachurs Throwback: \$7.56/Gal Triple Option: \$7.80/Gal \$30 Fertilizer Reallocation

Manual Soybean Planting Depth Study

Objective: To evaluate yield and economic performance of various manual soybean planting depths consisting of 1" to 2.75" in ¼" increments.

Results: Tables 1. illustrates planting depths at 1.5', 1.75" and 2" achieved the highest yields in this study. 2" planting depths obtained the optimum planting depth.

Table 2. reveals shallowing up planting depths to 1"to 1.25" resulted in overall economic losses of **-\$39.09** to **-\$61.42/A**. To help understand these results, it appears the combination of a later planting date of May 18th as well as a record hot and dry month of June, allowed for deeper planting depths to offer highest yields.

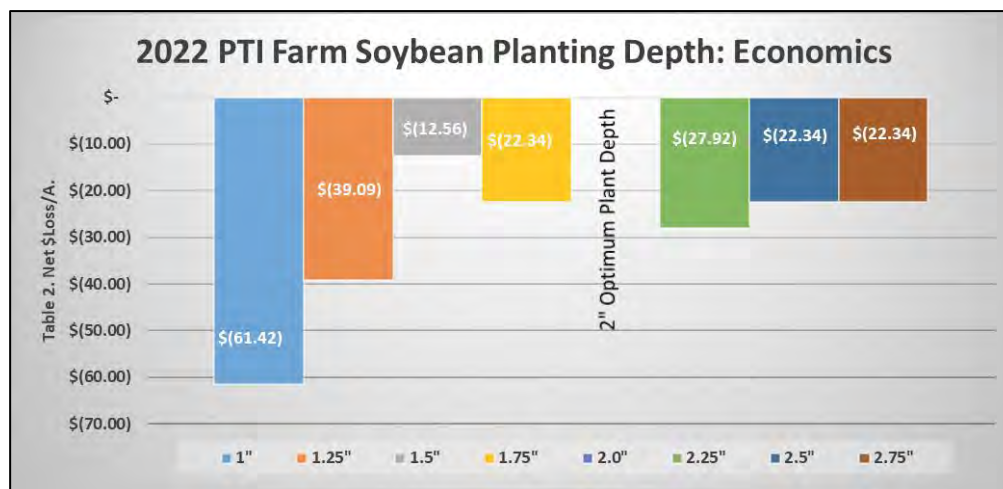
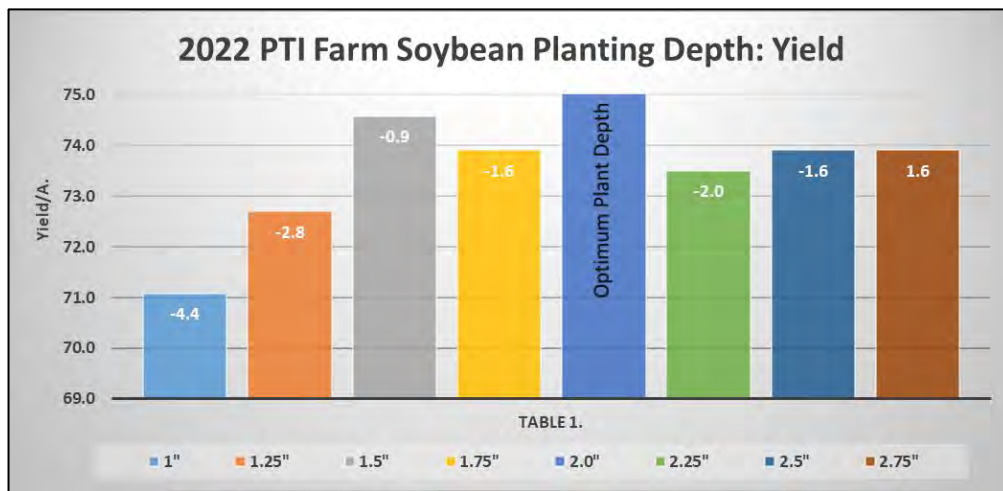

SmartDepth® Soybean Planting Depth Study

Objective: To evaluate yield and economic performance of various manual soybean planting depths consisting of 1" to 2.75" in ¼" increments, compared to automated variable depth planting using SmartDepth® control.

Digging seeds is a time consuming yet important task at planting time (Figure 1). Getting your eyes on the furrow where the seeds are placed, will allow you to understand if those seeds are in an environment to thrive. Is the seed being planted into adequate moisture? Until now, we didn't know this for every seed, and we were unfortunately simply guessing.

Figure 1. Seed Furrow



With a SmartFirmer® sensor (Figure 2.) you can now have virtual eyes in the furrow. Soil moisture is a critical component for seed germination, uniform plant emergence, and ultimately crop yield. SmartFirmer® sensors gives row-by-row visibility to soil moisture in the seed furrow, allowing farmers to choose the right planting depth as soil conditions change. Currently, the recommendation for ideal furrow moisture levels to achieve adequate soybean emergence, is near 32%. Using the 20|20® monitor (Figure 3.) in tandem with SmartFirmer® sensors, we now have the ability to evaluate furrow moisture in real-time. Based on this real-time information, growers can make decisions based on live sensing data.



Figure 2. SmartFirmer® Sensor

Planting Depth Study Continued

Figure 4. illustrates SmartDepth®, a unique product that takes the technology one additional step further, allowing planting depth to be changed on a planter, by section or individual row basis. This can be done manually from the tractor cab and 20|20® console, or automatically using furrow moisture values from SmartFirmer® sensors. Growers can customize their own settings to optimize both furrow moisture and planting depth values (Figure 5). This control allows growers to measure, react, and take control of planting depth to optimize emergence timing.

Figure 5. SmartDepth® Customization Screen



Figure 4. SmartDepth® Control System

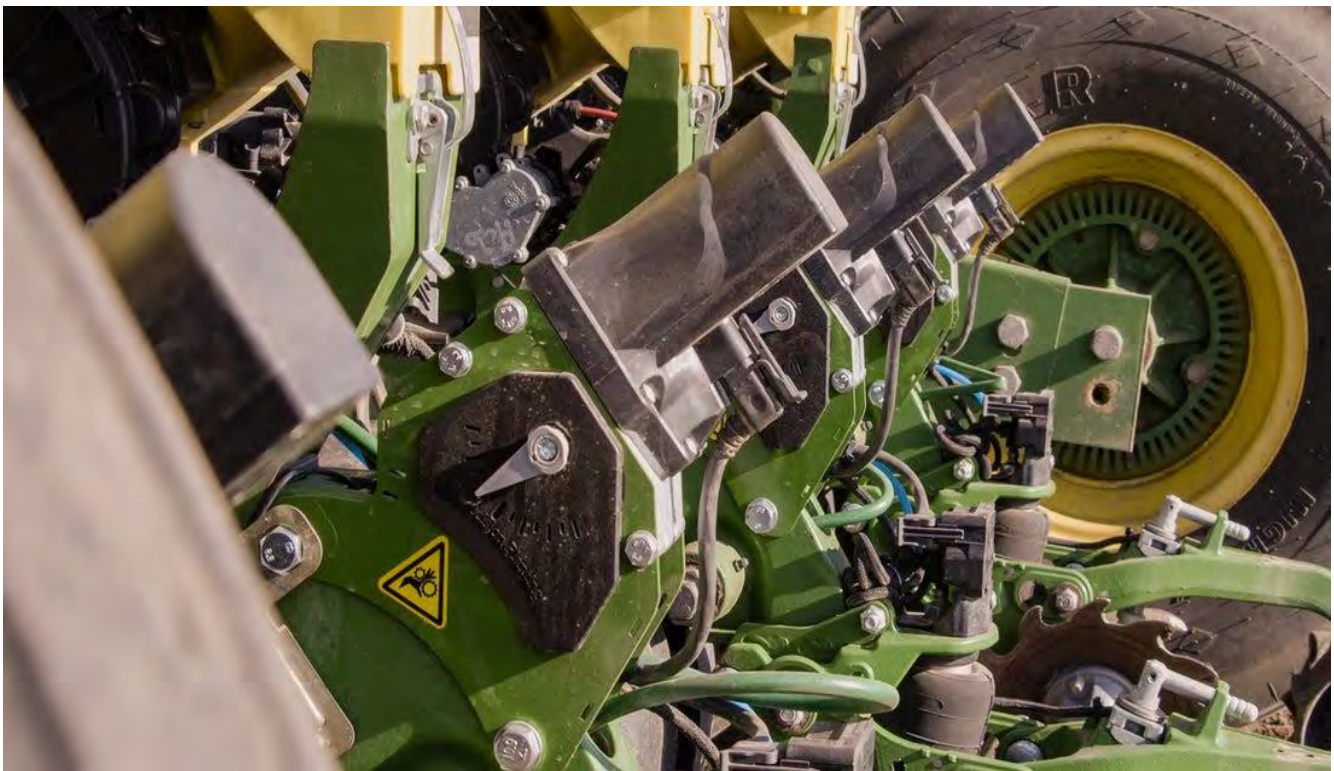

SmartDepth® Soybean Planting Depth Study

Results: Tables 1-2. reveal that SmartDepth® did not offer the highest yield in the study, but did obtain yield within 1.5 Bu/A. and \$20.94/A. compared to that of optimum planting depth.

Table 3. illustrates average furrow moisture of 36% across all planter rows when SmartDepth® was implemented to obtain ideal planting depth into moisture. Currently, the recommendation for ideal furrow moisture levels to achieve adequate soybean emergence, is near 32%.

More work needs to be done to understand how to continually customize settings to achieve proper planting depth automatically. However, it does appear that by using SmartDepth®, SmartFirmer® and a 20|20® monitor system, growers can measure and chase the furrow moisture line and adjust planting depths as they deem appropriate.

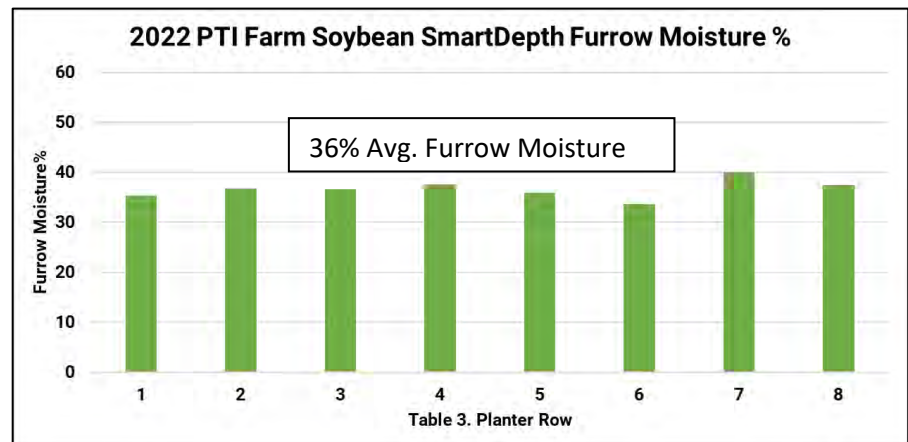
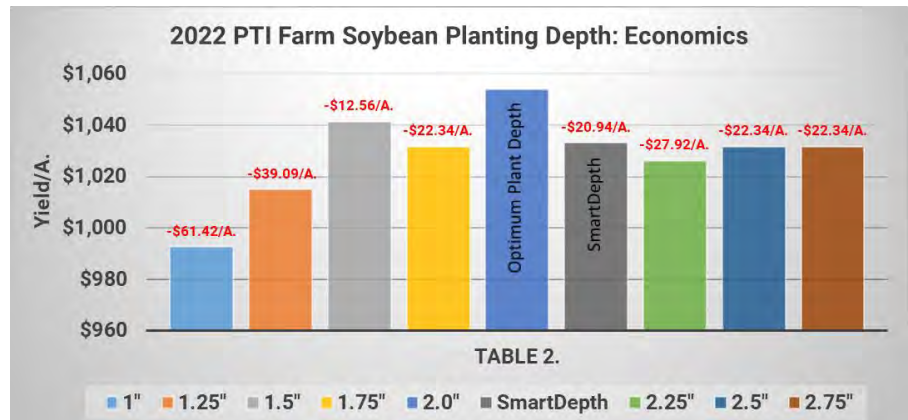
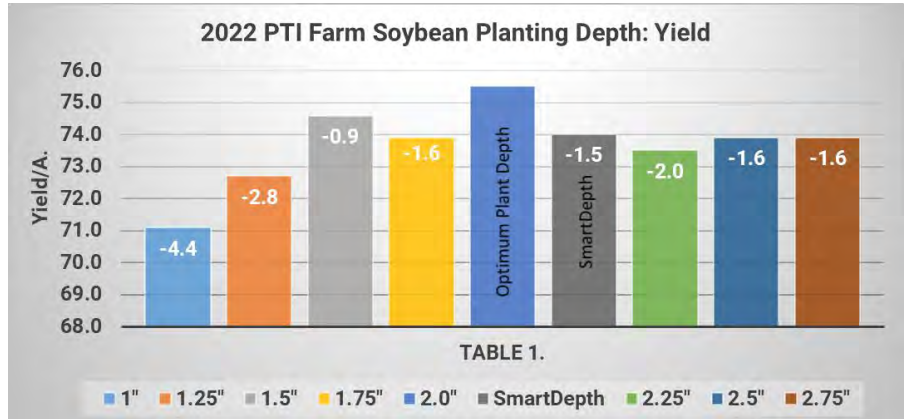

Reveal® Residue Management Study

Objective: This study evaluates the yield and economic benefit of Reveal® frame mounted row cleaners in a soybean after corn strip-till environment.

Residue management is a necessary part of today's operation to maximize profitability. Tougher stalks and more corn-on-corn acres mean a heavier load of residue that needs to be controlled. Residue in the seed trench competes with seedlings for moisture and can harbor diseases.

Reveal® (Figure 1-2.) is frame mounted, so unlike other row cleaners it gets rid of that row unit chatter. It has a gauge wheel that precisely controls the depth of the cleaning tines. It also has an airbag that makes sure the depth that it's set at, stays consistent. The pressure of the airbag can be controlled on the 20|20® monitor (Figure 3).

In this agronomic study, Reveal® is compared to the absence of row cleaners at 10, 20, and 30 PSI, in both Notch 1 and Notch 2 tine settings:

Figure 1. Reveal® System



Figure 3. 20|20® System



Reveal® Residue Management Study Continued

Results: Table 1. illustrates the Reveal® residue management system resulted in positive yield gains in all settings, averaging +3.75 Bu/A. compared to the absence of row cleaners. Yield response varied from +2.4 to +5.0 Bu/A. with 20PSI settings proving highest yield at +4.8 to +5.0 Bu/A. gains.



Residue management in the furrow is crucial for optimum yield and highest revenue potential. At \$13.96/Bu. soybeans, an average yield gain of +3.75 Bu/A. would result in increased farm revenue of \$52.35/A. and proves to be a core principle of planting that a grower should not overlook.

Figure 3. Reveal® System

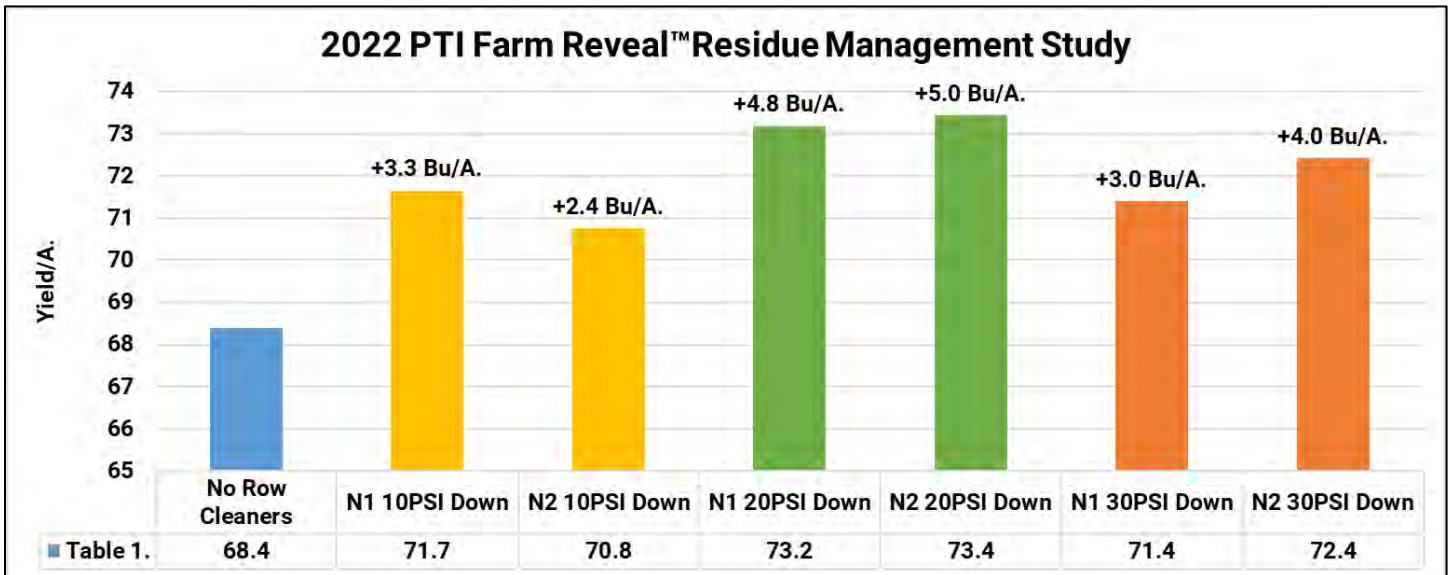

CleanSweep® Residue Management Study

Objective: This study evaluates the benefits of planter row cleaners equipped with CleanSweep® cylinders. Residue management has become a necessary part of today's operation to maximize profitability. Tougher stalks and more corn-on-corn acres mean a heavier load of residue that needs to be controlled. Residue in the seed trench competes with seedlings for moisture and harbors disease. CleanSweep® cylinders put row cleaners right where they need to be, moving residue but not the soil. Continuous adjustments can be made as field conditions change with the cab-mounted controller to easily lift or make more aggressive adjustments.

Figure 1. CleanSweep® System

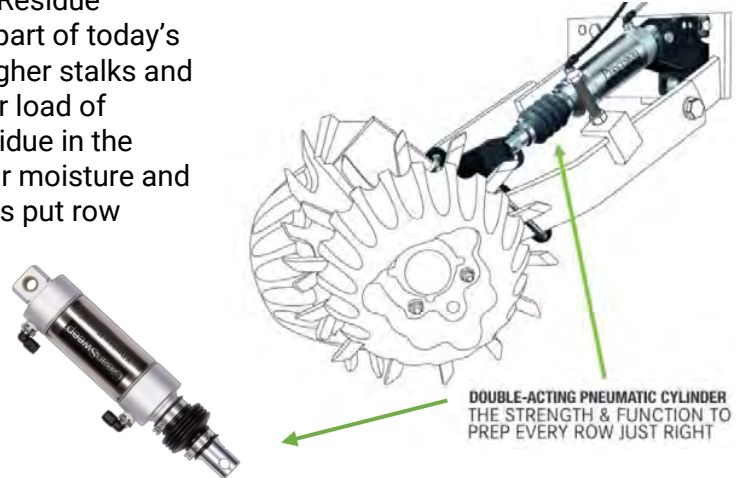

In this study, we use air pressure to adjust CleanSweep® cylinder settings to allow the ability to change and evaluate the aggressiveness of row cleaners. These settings were then evaluated to study yield and economic advantages.

These agronomic settings consisted of:

1. Lifting the row cleaners 100% to simulate the lack of row cleaners
2. A "floating" (0# psi) position that allows the row cleaner to ride along top of the soil surface with no air control, lift, or down-pressure.
3. 20# of air down-pressure, just aggressive enough to wipe crop residue and clods out of the way to lead a clean path ahead of the planter gauge wheels and seed disc openers.



CleanSweep® Residue Management Study Continued

Results: Table 1. illustrates CleanSweep® system yield results from the past 5 years at the PTI Farm. 100% lift (no row cleaners), resulted in yield losses of **-3.3 Bu/A.** and floating row cleaners proved losses of **-0.5 Bu/A.** compared to the 20#psi down setting. At \$13.96 soybeans, 100% lift resulted in losses of **-\$46.07/A.** while floating **-\$6.98/A.**

Table 2. summarizes multi-year data from 2020-2022, indicating floating row cleaners realizing net economic losses of **-\$12.77/A.** and 100% lift at **-\$37.31/A.**

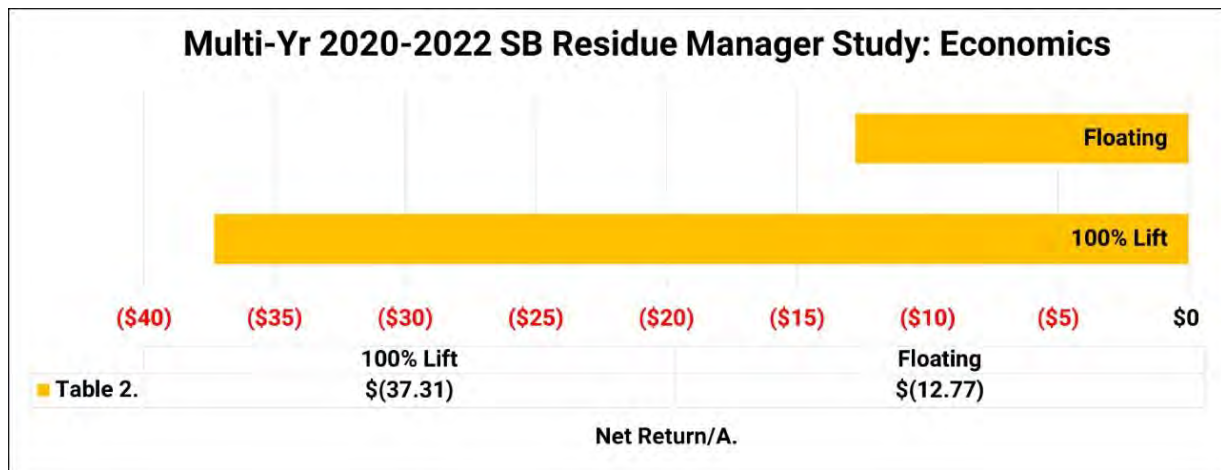
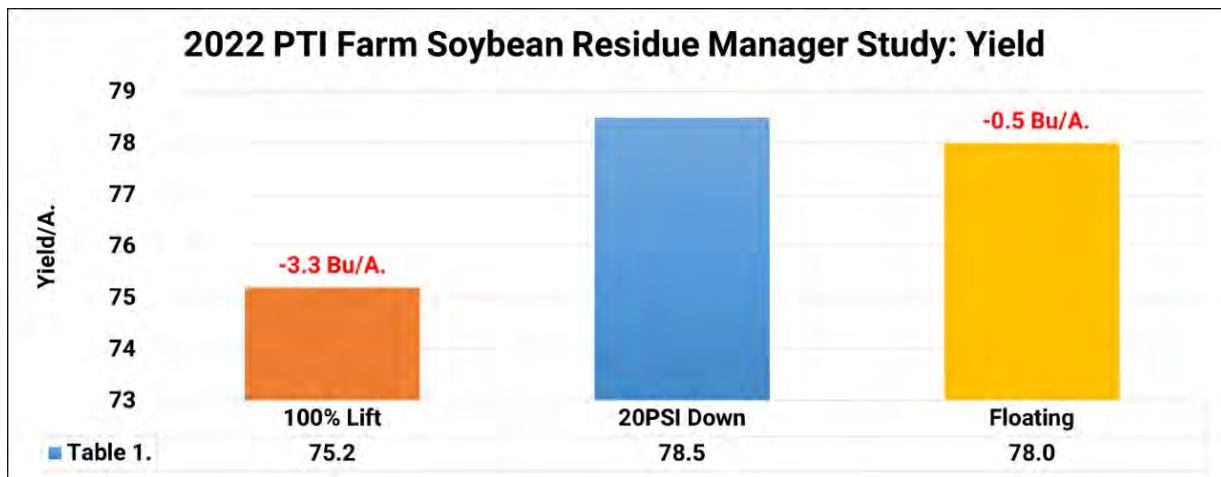

DownForce Management Study

Objective: This soybean study evaluates yield impact of implementing proper downforce compared to too light or too heavy row unit settings. Planter row unit downforce is a common agronomic issue that often goes unaddressed. When downforce matches field conditions, the depth of planting is consistent and correct. Too light of row unit downforce causes planting depth to shallow up, potentially placing seed in dry soil, creating poorly rooted plants that struggle for water and nutrients. Conversely, too much downforce can lead to furrow side-wall compaction, also creating an environment that can cause limited plant access to water and nutrients.

DeltaForce® system replaces the springs or air bags on your planter with hydraulic cylinders (Figure 1). It automatically increases or decreases weight with military precision, on each row individually. When one row encounters conditions different than another (wheel tracks, old roadbeds, clay knobs, headlands, etc.), each will adjust independently (Figure 2). Row by row, foot by foot, even seed by seed an environment that fosters uniform germination, optimum growth and maximum yield can be produced.

Figure 1. DeltaForce® Cylinder



Figure 2.

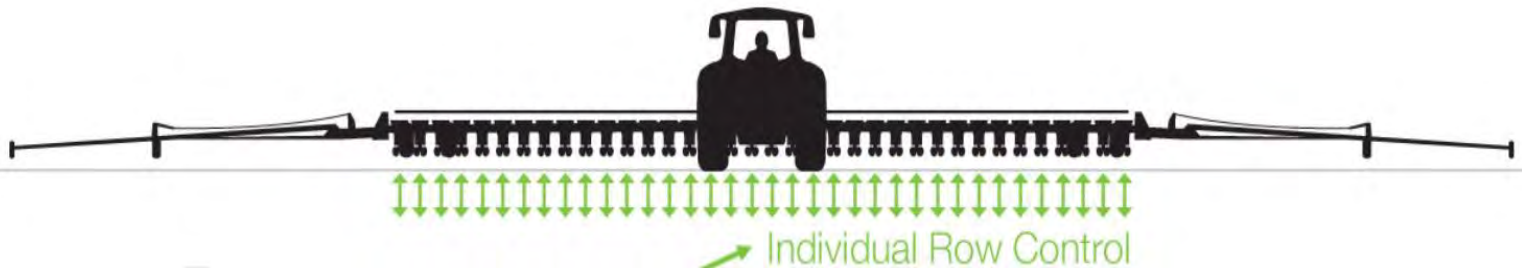

DownForce Management Study Continued

Results: Tables 1-2. illustrates the yield and economic response of DeltaForce® automated control compared to excessive and light downforce settings. Settings for this study include;

- Too light of Downforce (175# lift, 100# down)
- Proper Downforce (Automated Custom 90#)
- Excess Downforce (550# down, 100# up)

2022 data resulted with light downforce realizing yield losses of **-0.7 Bu/A.**, with corresponding net economic losses of **-\$9.77/A.** Heavy downforce caused yield losses of **-0.9 Bu/A.**, with economic losses of **-\$12.56/A.**

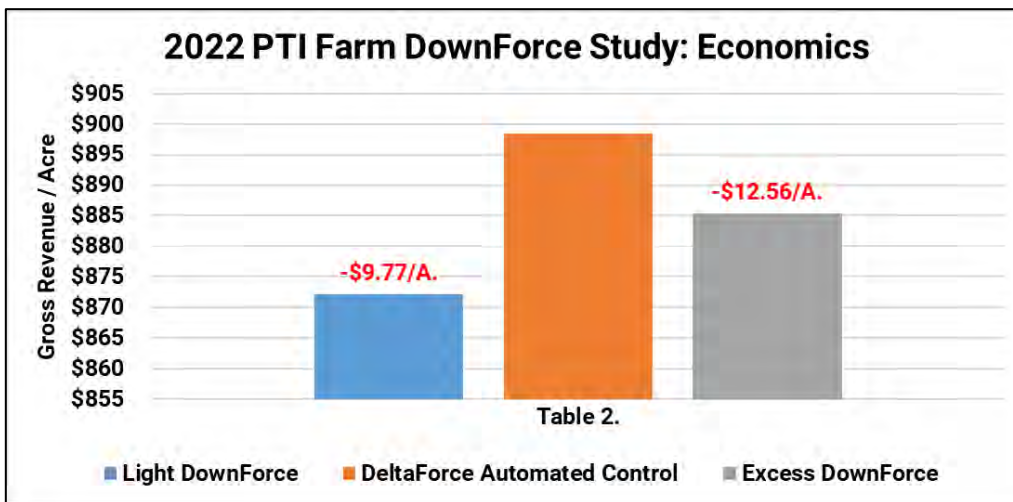
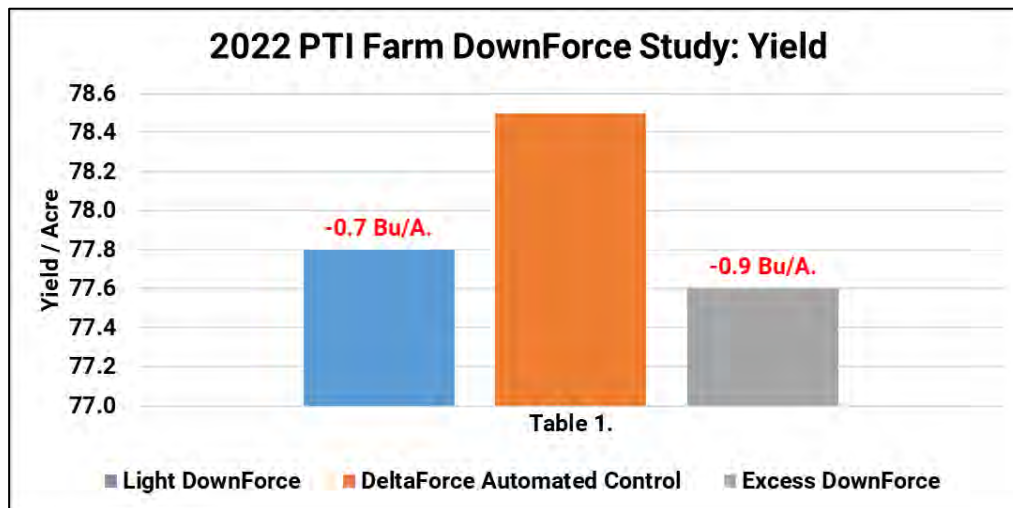

DownForce Management Study Continued

Tables 3-4. illustrate multi-year data which resulted in light downforce having yield losses of **-2.13 Bu/A.**, with corresponding net economic losses of **-\$23.42/A.** Heavy downforce caused yield losses of **-1.43 Bu/A.**, with economic losses of **-\$16.05/A.**

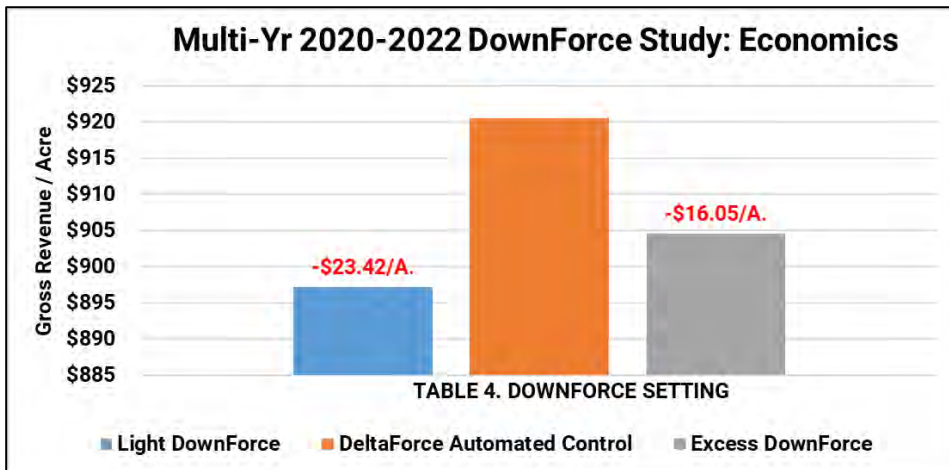
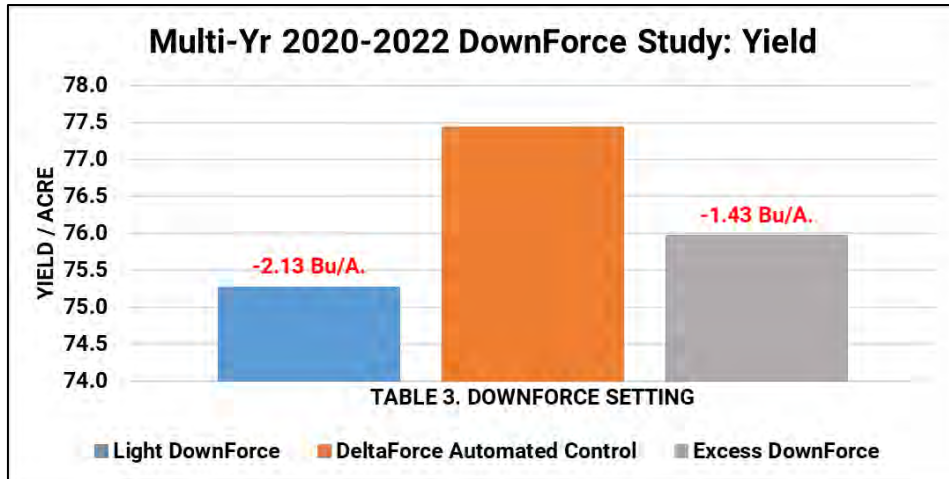

Keeton® Seed Firmer Study

Objective: This study evaluates the benefits of Keeton® Seed Firmers (Figure 1). Seeds don't always land right in the bottom of the trench where they belong. With its unique, in-the-trench design, the Keeton® Seed Firmer gently firms those seeds to the bottom of the V-trench (Figure 1). The end result is even depth, correct seed-to-soil contact, and most importantly uniform germination.

Results: The table below illustrates multi-year data over the time period of 2020-2022 where Keeton® Seed Firmers resulting in yield gains of +1.4, +0.74, and +0.9 Bu/A. Using average soybean prices for each individual year, Keeton® Seed Firmers resulted in average economic gains of +\$11.69/A.

At a cost of \$35/row for Keeton® Seed Firmers and quick attach brackets for a 16-row planter, using the +\$11.69/A. increase in revenue, break-even occurs at only 48 acres.

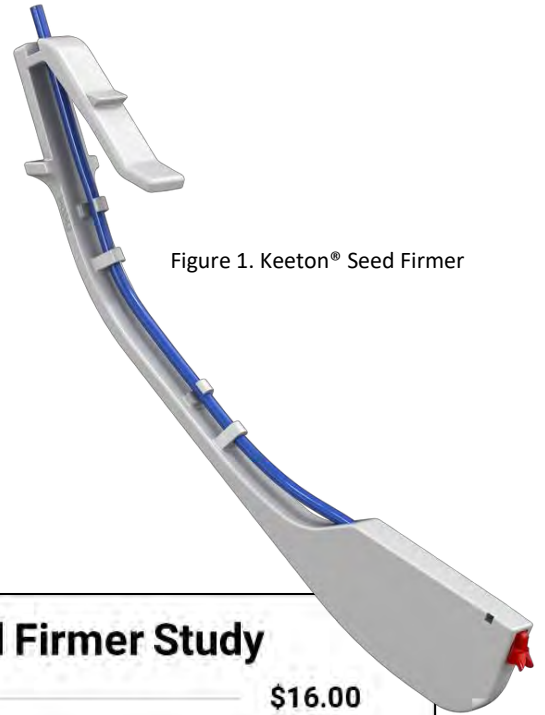
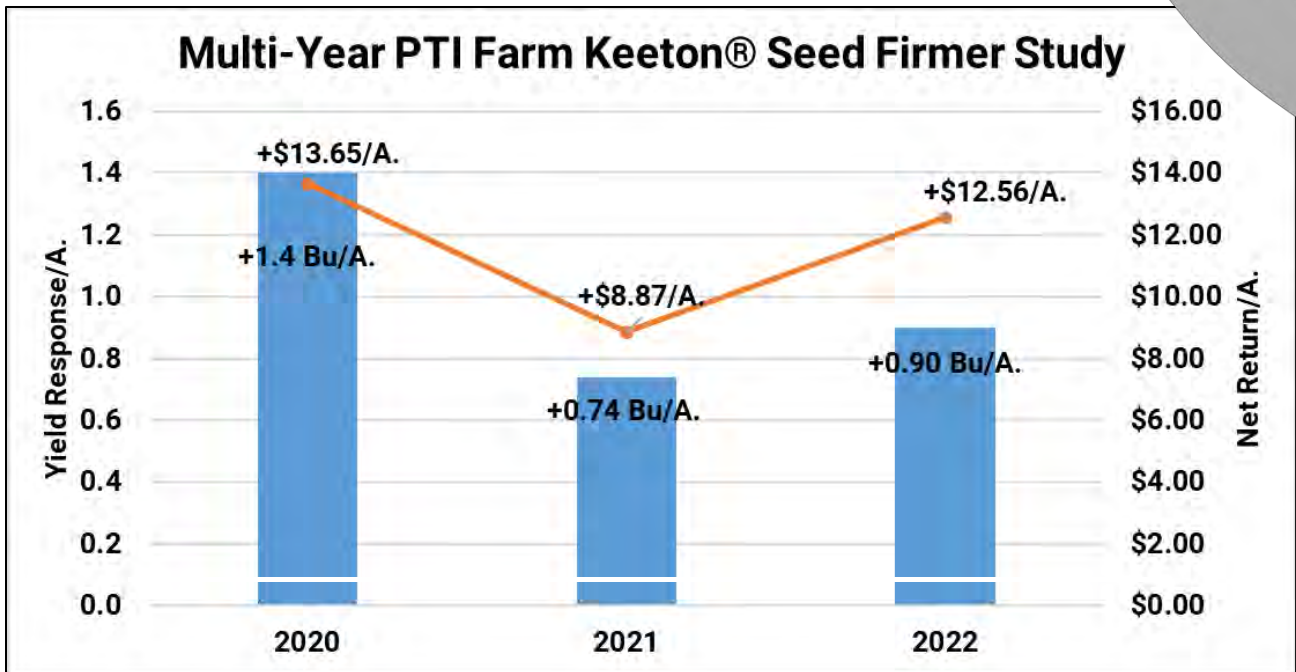

Figure 1. Keeton® Seed Firmer



Planting Date: May 17th

Variety: Pioneer 37A18E

Population: 130K

Row Width: 30"

Rotation: BAC

Soybean Price: \$13.96

Soybean Singulation Study

Objective: To evaluate the agronomic and economic advantage of singulating soybeans. In this study we compare the use of an 80-hole vs 56-hole soybean crop kit (Figure 1). Typical spacing of soybean plants achieved with singulation is illustrated in Figure 2.

Figure 1.

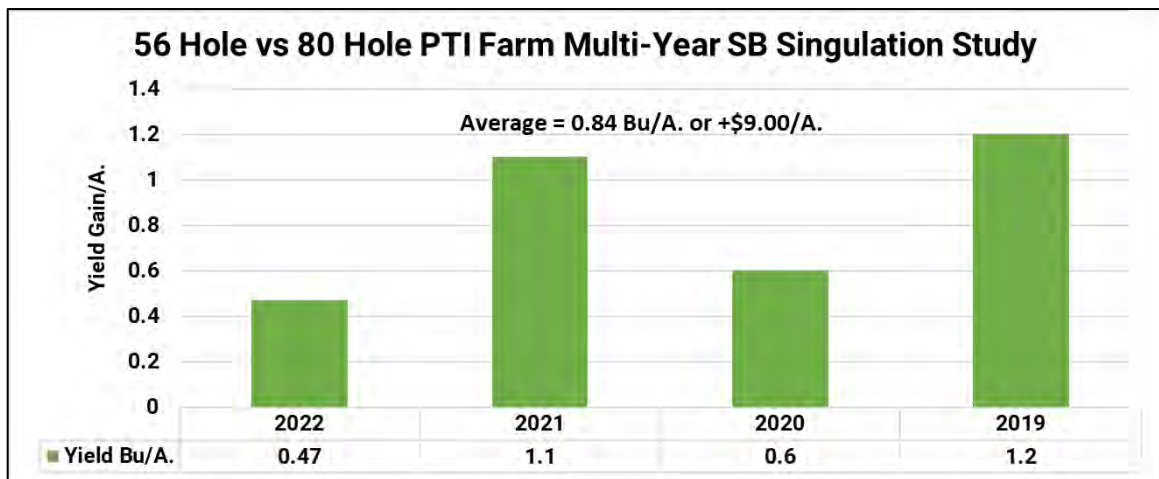

Figure 2.



Results: The table below summarizes the yield increase of singulating soybeans with a 56 hole crop kit. 2019-2022 proved a +0.84 Bu/A. yield gain over this time period. Using these yield gains, along with the commodity price for each year, shows a \$9.00/A. advantage over the gray 80 hole-disc.

The cost of upgrading to the 56-hole disc and new ejector wheel is \$16 a row assuming you already have a singulator. When using multi-year economic data, on a 16-row planter it would take a grower 29 acres to break-even on this low cost investment.



SeedRight BundleDrop Singulation Study

Figure 1. BundleDrop Plate

Objective: To evaluate the agronomic and economic advantage of planting soybeans into “bundles”. The SeedRight BundleDrop plate allows the ability to plant soybeans in bundles of four seeds. This “team” approach is designed to help improve emergence and overall plant stand by multiple soybean plants emerging at the same time in a concentrated area to fight through soil crusting.



Results: Table 1. illustrates a yield detriment of **-2.7 Bu/A.** for bundling seeds of four together with the SeedRight disc.

In 2022, ideal planting conditions create no significant soil crusting to cause emergence concerns. As a first-year study with this product, we look forward to testing this in the future when significant soil crusting could occur to study any advantages in those conditions.

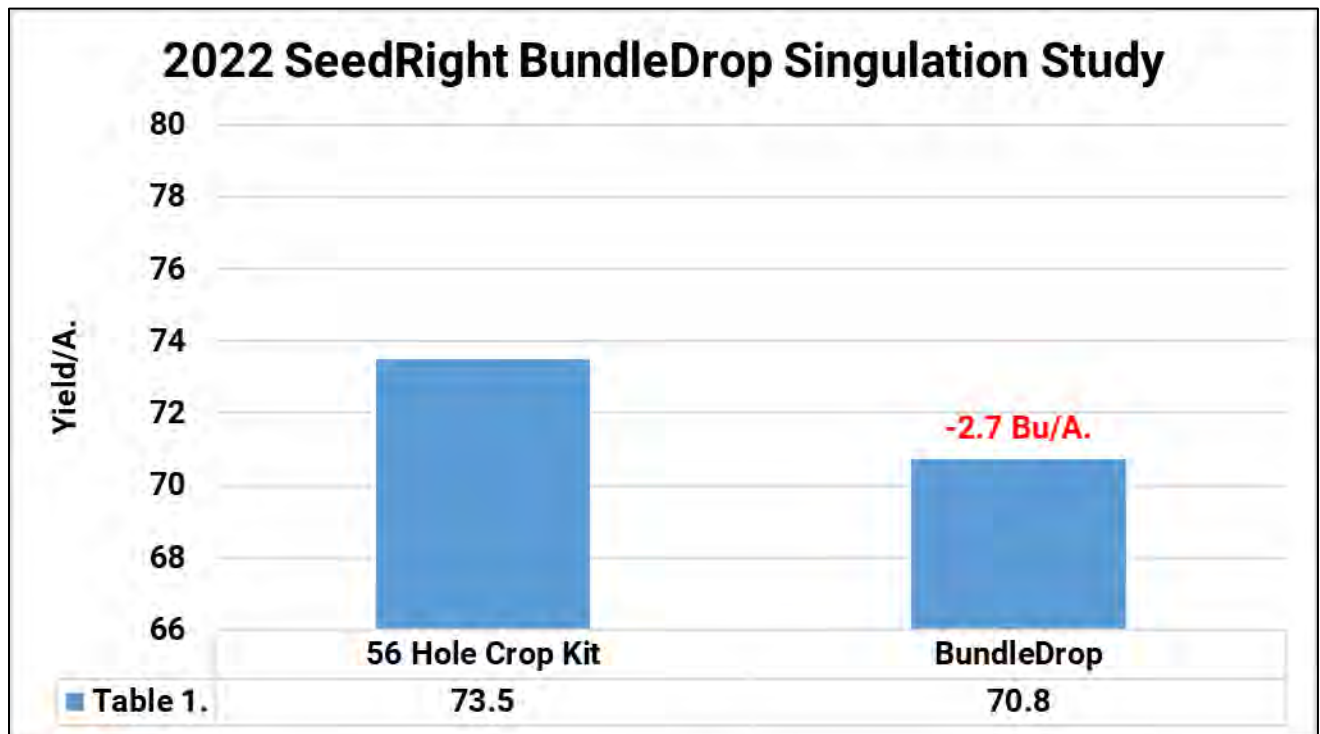

STP Opening Disc Study

Objective: This study evaluates the use of 3 different types of opening discs from Prescription Tillage Technology L.L.C.



STV STANDARD TRUE V

Standard True “V” Blade with Anti-Stubbing or Dulling Technology

- Shallow and full planting depth
- Sharp gravel and shale rock conditions
- Standard soils and planting conditions
- Standard and offset true-V planter configurations
- Available with off-set blade configurations on standard planters
- Fits John Deere, Kinze, Harvest International, Horsch, Monosem, White and Precision



STP SABRE TOOTH PLANTER

True “V” & Single Blade Applications

- 1" minimum to full planting depth
- Challenging soil and planting conditions
- Challenging residue conditions
- Standard planter configurations
- Enhances early and late root development
- 14.75" inside with 15" outside combination fits John Deere, Kinze, Harvest International, Horsch, Monosem and older White
- 15.75" inside with 16" outside combination fits newer White and Precision



STPS SABRE TOOTH PLANTER SHALLOW FILLET

Shallow Planting Sharp Gravel & Shale Rock Conditions

- Shallow and full planting depth for cotton, canola, and shallow seed placement requirements
- Sharp gravel and rock conditions
- Challenging soils and planting conditions
- Enhances early and late root development
- .100 cut out
- 15" inside with 15" outside combination fits John Deere, Kinze, Harvest International, Horsch, Monosem and older White
- 16" inside with 16" outside combination fits newer White and Precision



STP Opening Disc Study Continued

Results: The table below illustrates multi-year data over 2021 -2022 of each of Prescription Tillage Technology’s opening discs performance compared to the smooth STV disc as the control. STP (aggressive) openers realized a **-1.9 Bu/A.** loss to the smooth STV discs, which resulted in an economic loss of **-\$17.35/A.** STPS (mild) discs resulted in **+0.5 Bu/A.** increase over the smooth STV disc with increased revenue of **+\$5.41/A.**

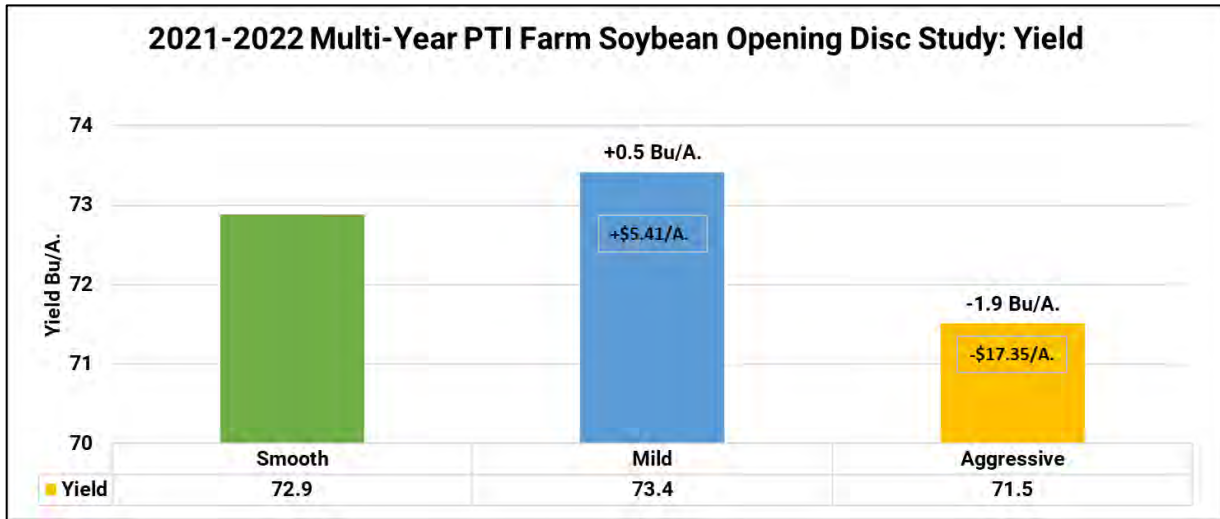

STP disc installed on Harvest International® planter



“U” Furrow created by STP



True “V” created by standard opener discs

Planting Date: May 18th

Variety: Golden Harvest® 3902E3

Population: 130k

Row Width: 30"

Rotation: BAC

Soybean Price: \$13.96

High Speed Soybean

Objective: To evaluate yield response of planting speeds 5 and 10 MPH with a SpeedTube® and regular seed tube system. SpeedTube® high-speed planting technology takes the place of conventional seed tubes and consists of a flighted belt. By transporting each seed to the furrow, there is no opportunity for seeds to ricochet into the trench. Even at twice normal planting speeds, seed arrives safely at the bottom of the trench, spaced evenly, every time.

Results: Using SpeedTube® technology, there was only a 0.1 Bu/A. range difference at planting speeds of 5MPH between the two systems. However, at 10MPH SpeedTube® proved additional yield gains of +1.8 Bu/A. compared to a normal seed tube system.

This data would suggest that growers can plant at significantly higher speeds with SpeedTube® technology without sacrificing planter performance.

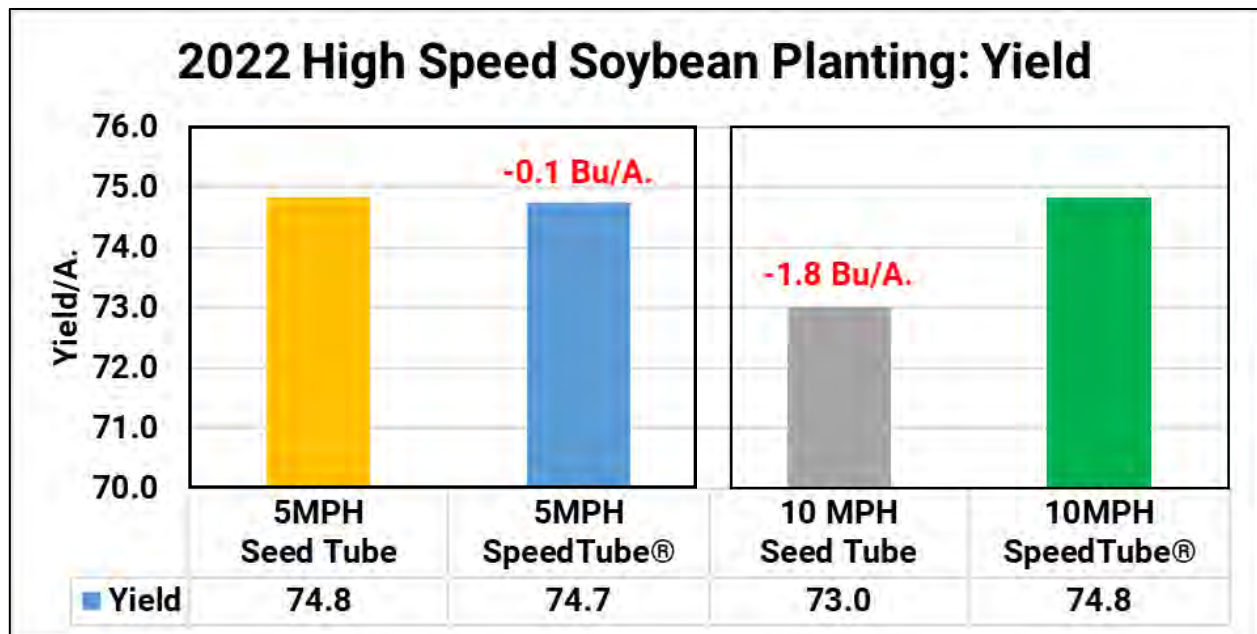

Soybean Tillage/Closing Wheel Study

This tillage/closing study evaluates five distinctly different types of closing wheel systems including the following:



FurrowForce® Closing and Sensing Control System:

Advantages: Lifts and fractures sidewall compaction/smear
2nd stage stitching and removal of air pocket
Automatic sensing/control of soil variability

Disadvantages: Rocks can be problematic, increased cost



Non-Sensing Traditional Dual Rubber Closing System:

Advantages: Sealing or "Pinching" in dry conditions

Disadvantages: Difficult to lift/fracture sidewalls, struggles to close furrow



Non-Sensing Dual Yetter Poly Twister® Closing System:

Advantages: Lifts and fractures sidewall compaction/smear
Center ring acts as depth maintainer

Disadvantages: Lightweight wheels require increased tension



Non-Sensing 360 Wave™ Closing System:

Advantages: Rolls a wave of moist soil over seed to prevent drying out

Disadvantages: Only addresses one side of furrow.



Non-Sensing Integrated Ag Solutions "The Closer" System:

Advantages: Swept back design destroys sidewall compaction
Poly wheels are corrosion resistant

Disadvantages: Lighter weight wheels may require increased tension

Soybean Tillage/Closing Wheel Study Continued

Four tillage systems were evaluated in the study to evaluate the difference in closing performance.

Vertical-Till (Figure 1.) In the fall after harvest, vertical tillage was used to mix, cut, and level residue in a 3" depth tillage pass. Herbicide was used as a burndown to control early season weeds in the absence of spring tillage.

No-Till: (Figure 2.) Planting directly into last year's corn stalks with no tillage activity performed. Herbicide was used as a burndown to control early season weeds in the absence of tillage.

Conventional-Till (Figure 3.) In the fall after harvest, deep 13" ripping with aggressive cutting and mixing of residue. A spring soil finisher leveled before planting.

Strip-Till (Figure 4.) In the fall after harvest, 10" deep strips were created with a strip-till unit. Herbicide was used as a burndown to control early season weeds in the absence of spring tillage.

Figure 1. Sunflower® 6833 Vertical-Tillage Tool



Figure 2. No-Till Planter



Figure 3. Sunflower® 4630 Disc-Ripper



Figure 4. Kuhn® Krause® 1200 Gladiator® w/ Montag® Fertilizer Cart



Soybean Tillage/Closing Wheel Study Continued

Results: Conventional Till: All closing systems, with the exception of the 360Wave™, proved positive yields over FurrowForce®. Dual rubbers offered highest yields of +1.6 Bu/A. After planting, hot dry conditions persisted thru June, which might lead to the thought of a more packing and sealing closing system holding more moisture.

Vertical-Till: FurrowForce® proved positive yield gains compared to all other closing systems by +1.2 to +4.3 Bu/A. In this more difficult to close planting environment, dual traditional rubbers proved highest yield losses of **-4.3 Bu/A.** and revenue losses of **-\$60.03/A.** All other closing systems resulted in revenue losses of **-\$16.75 to -\$41.88/A.**

Strip-Till: Small yield range of only 0.9 Bu/A. between all systems. All closing systems performed similarly in this tillage system with revenue variance of **-\$1.40 to -\$12.56/A.,** with dual rubbers lagging behind the group.

No-Till: FurrowForce® outperformed all systems with yield gains of +1.0 to +4.6 Bu/A. In this tougher to close type environment, all systems suffered, however dual traditional rubbers provided the largest discrepancy with yield deficit of **-4.6 Bu/A,** and revenue losses of **-\$64.22/A.** All other closing systems lost **-1.0 to -2.8 Bu/A.** with revenue losses of **-\$13.96 to \$39.09/A.**

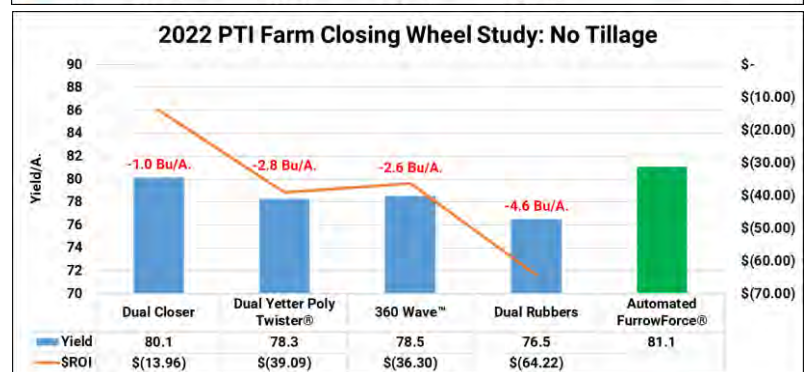
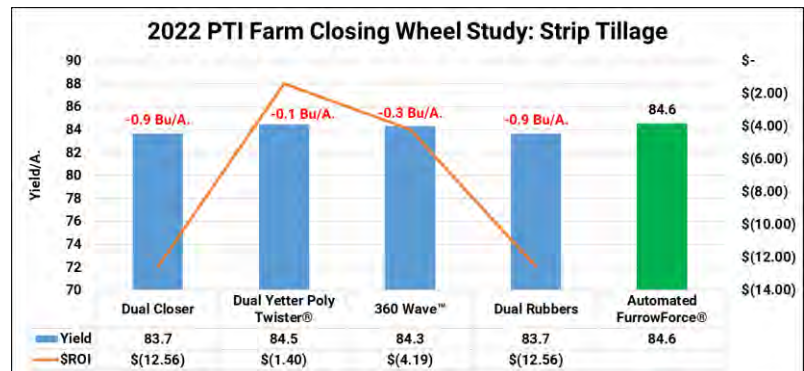
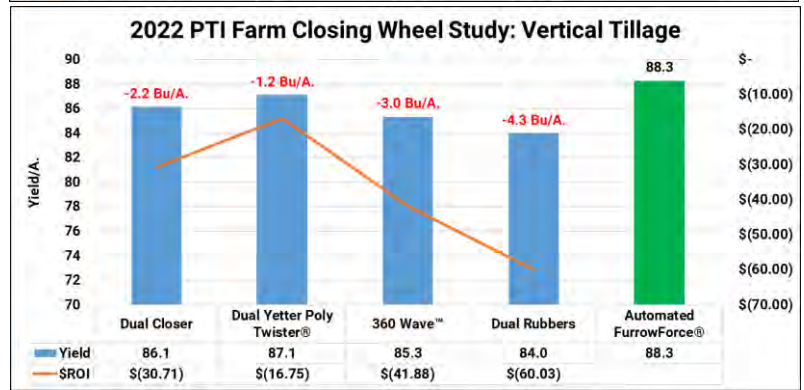
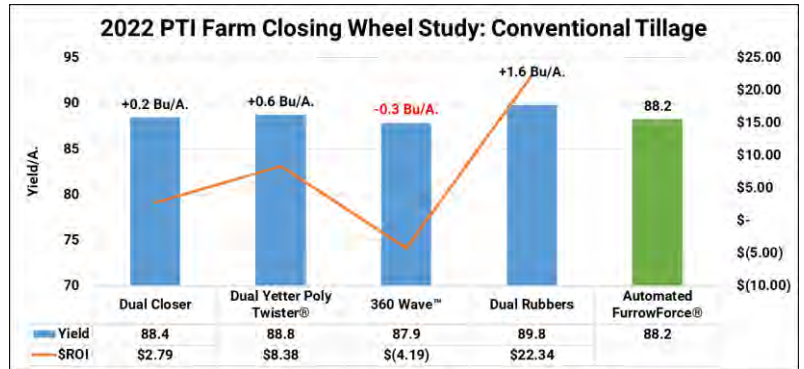

Soybean Closing Wheel Study Continued

Overall, FurrowForce® two-stage automatic closing resulted in average yield gains of +1.4 Bu/A. and additional revenue of +\$19.02/A. across all tillage environments.

However, the clear advantage for FurrowForce® occurred in reduced tillage environments such as no-till and vertical tillage. In these programs, yield gains of up to nearly +5.0 Bu/A. with increased revenue of nearly +\$40/A. to clearly indicate that in tougher closing situations, a more robust system is needed to effectively close.

In summary, for years planters have struggled

with closing systems with manual settings that offered the inability to account for and change for varying soil conditions. Today, we are excited that technology finally exists where farmers can use sensing technology on the planter row unit to determine how much force is needed on closing systems to address soil variability. By using a robust 2-stage closing system, load pin and sensing architecture, partnered with a 20|20® monitor, farmers can be confident of closing the seed trench, eliminating sidewall compaction/smearing, and removing air pockets all while planting through various seedbed conditions on a pass-pass basis.

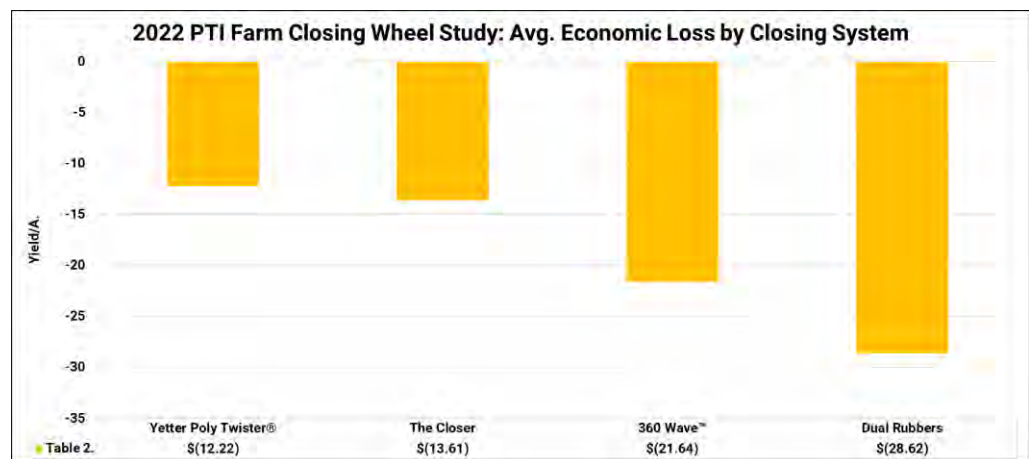
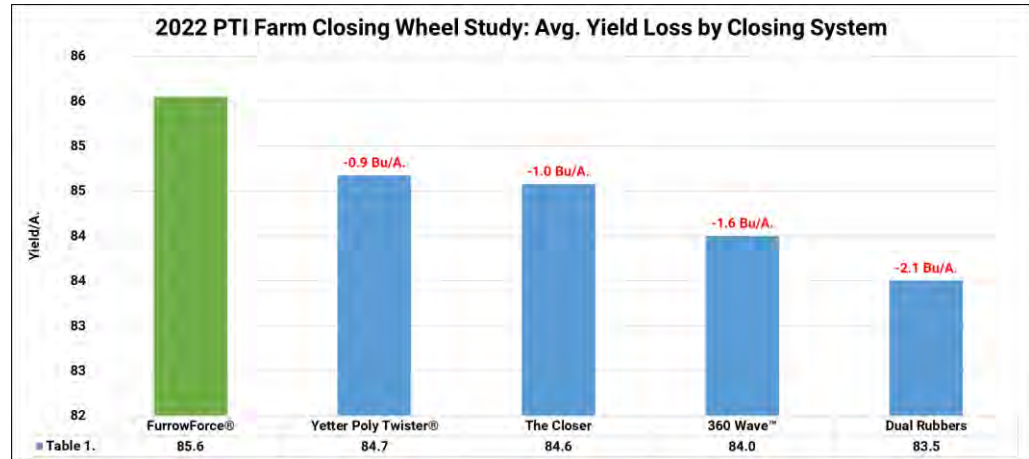

Rosens Stride Bio™ Hopper Box Treatment Study

Objective: To evaluate yield and net return of Stride Bio™, a talc graphic/micronutrient planter box treatment.

Stride Bio is a 80/20 talc graphic blend for planters that also contains Calcium, Magnesium, Sulfur, Iron, Manganese, and Zinc. It places essential nutrition, flow agents, and crop enhancement components directly on the seed to aid in singulation and improve seedling vigor and growth.



Results: Stride™ Bio hopper box treatments offered average yield gains of +0.97 Bu/A. with a positive net return on investment of +\$10.36/A.

As a first year product study, we look forward to testing this product again in 2023.

Guaranteed Analysis
0-0-0

Calcium (Ca).....	1.0%
Magnesium (Mg).....	0.5%
Sulfur (S).....	4.0%
4.0% Combined Sulfur	
Iron (Fe).....	0.1%
0.0% Water Soluble Iron	
Manganese (Mn).....	4.0%
4.0% Water Soluble Manganese	
Zinc (Zn).....	10.0%
4.0% Water Soluble Zinc	
Derived from: Dolomitic Limestone, Iron Oxide, Manganese Sulfate, Zinc Sulfate, Zinc Oxide.	

Also contains non-plant food ingredients: Talc & Graphite in an 80/20 ratio.

GENERAL INFORMATION
Stride Bio places essential nutrition, flow agents, and crop enhancement components directly on the seed to aid in singulation and improve seedling vigor and growth. Stride Bio is compatible with fungicide, insecticide seed treatments and inoculants, but does not replace those products. Stride Bio replaces the need for adding talc or graphite.

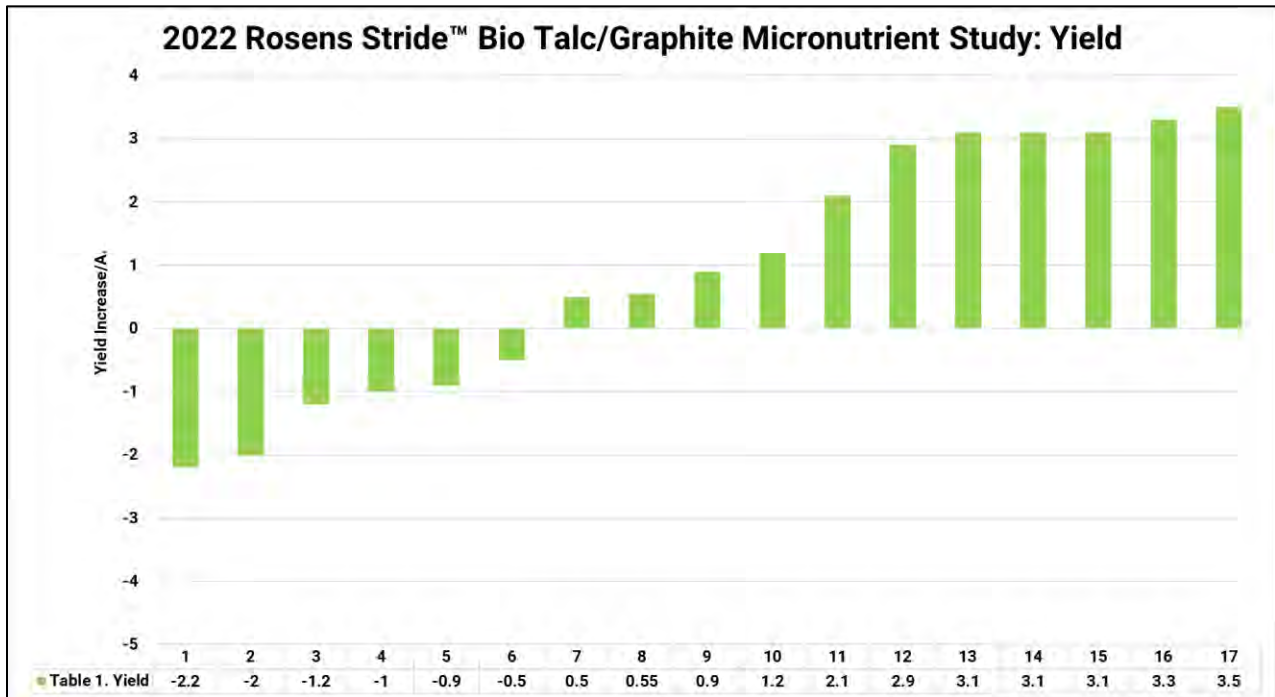

TerraMax FurrowJet® Liquid Inoculant Study

Objective: To evaluate the use of TerraMax Liquid-IF, a soybean inoculant containing Bradyrhizobium japonicum. For this study, TerraMax is applied in-furrow using FurrowJet® center only applications (Figure 1).



Figure 2. Precision Planting FurrowJet® At-Plant In-Furrow Application

Results: TerraMax Liquid-IF FurrowJet® treatments resulted in yield gains of +1.1 Bu/A. At a \$13.96 soybean commodity price and a product cost of \$3.78/A., TerraMax Liquid-IF offered economic gains of \$11.58/A.

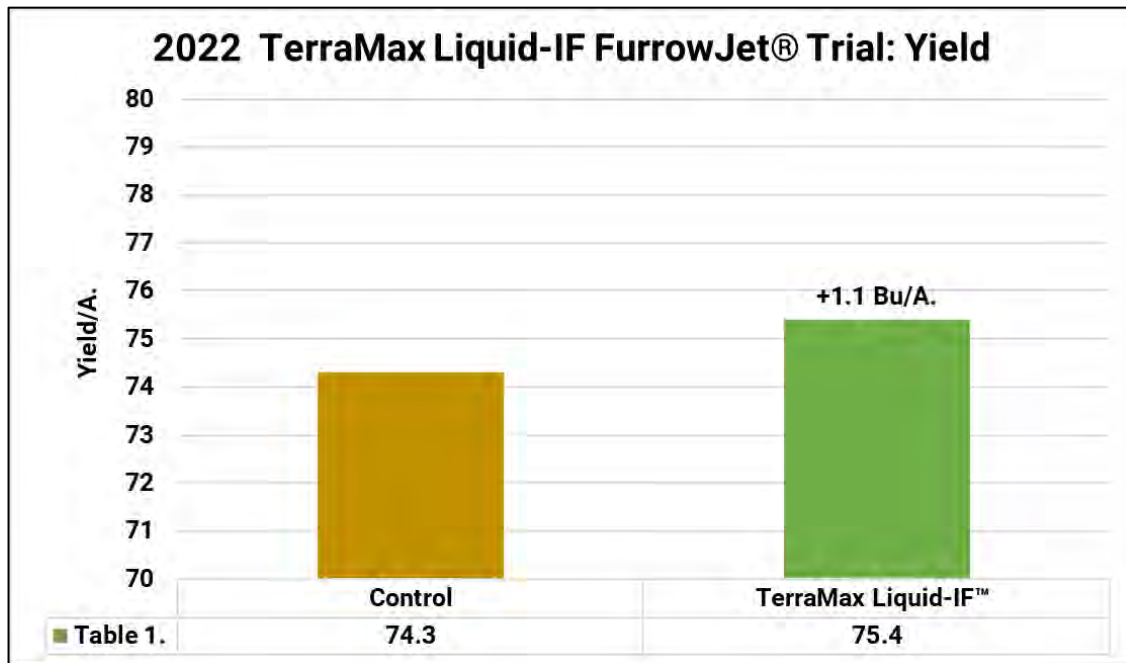

Rootella® F Hopper Box Soybean Inoculant Study

Objective: To evaluate yield and net return of Rootella® F planter box treatment.

Rootella® F concentrated fine powder mycorrhizal inoculant inoculates plants with vigorous endomycorrhizal fungi. The mycorrhizal inoculation improves plant nutrient uptake and has been proven to improve crop yield; reduce fertilizer, compost, and irrigation requirements; and increase plant durability under stress. Rootella® F mycorrhizal inoculants are ideal for manual mixing with seeds. This product formulation clings to seeds and lends itself well to the planter box applications.



Results: Hopper box treatments of Rootella® resulted in yield gains of +0.3 Bu/A. At a \$13.96 soybean commodity price and a product cost of \$6.50/A., Rootella® just fell short of positive economic gains at **-\$2.31/A.**

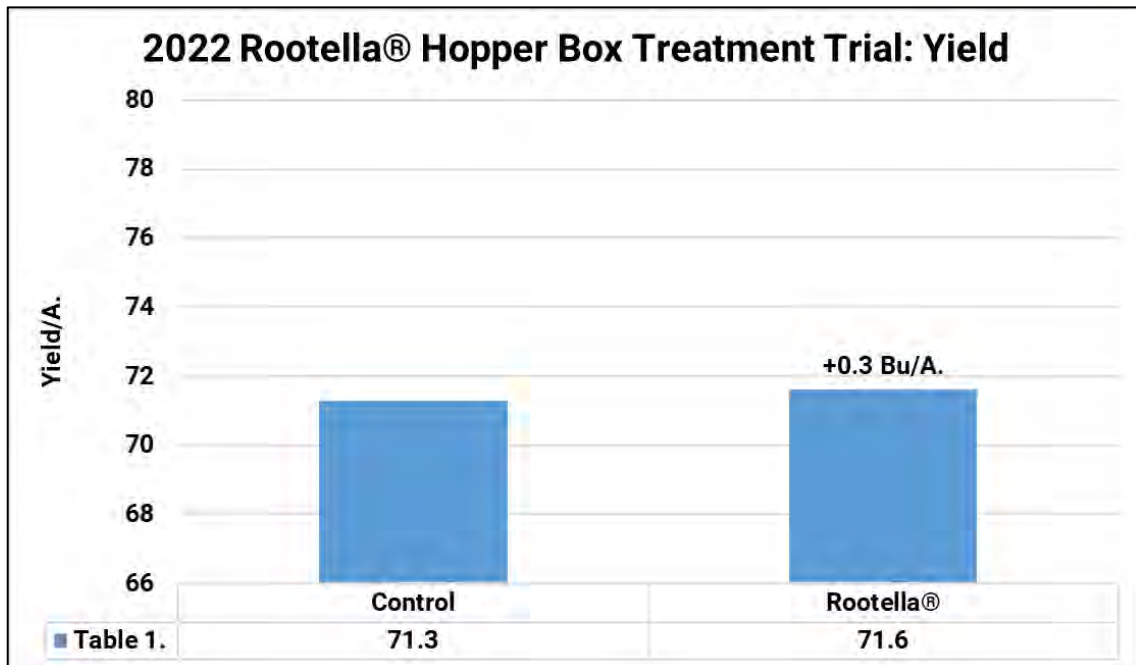

Soybean Cover Crop Study:

Objective: This trial is designed to evaluate the yield and economic benefits of a cover crop system in a soybean/corn rotation. To evaluate long-term benefits, this trial has been designed as a 10-year study. 45#/A. of cereal ryegrass was planted in the fall of 2020 (Figure 1.) and strip-till was then used as the primary tillage system after the ryegrass emerged.

In the spring, soybeans were planted directly on the fall strips and into the green cover crop (Figure 2). Termination of the cover crop was implemented at when rye achieved 24" in height.

Figure 1. Fall Cover Crop Seeding



Figure 2. Planting on Strip-Till into Green Cover



Soybean Cover Crop Study Continued

Results: Table 1. illustrates soybeans in the cover crop system proved **-1.3 Bu/A.** yield losses to the non-cover crop control.

Table 2. depicts net return on investment of the cover crop system. After the small yield loss and cost of seed and planting, the cover crop system offered economic losses in 2022 of **-\$40.92/A.**

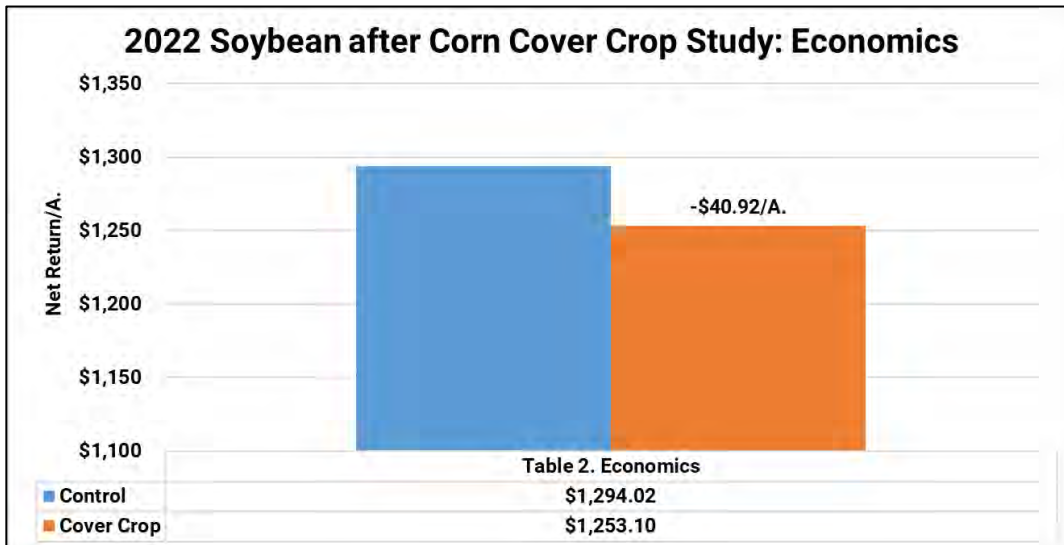
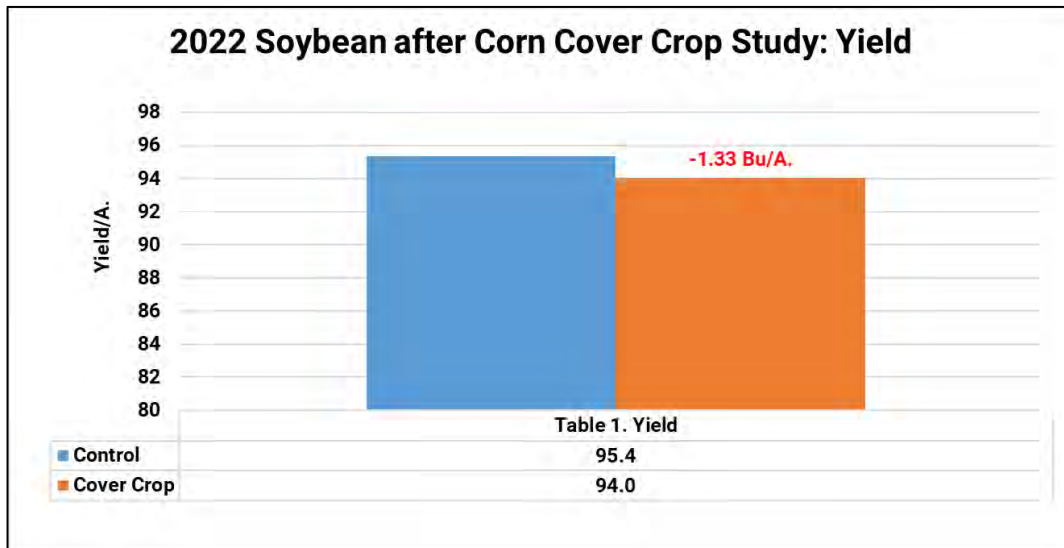

Soybean Cover Crop Study Continued

Table 3. illustrates multi-year yield data. This cover crop trial is designed as one of many ten-year studies at the PTI Farm. After two years of evaluating soybeans planted into a cover, yield gain today stands at just +0.23 Bu/A.

More importantly, Table 4. explains the multi-year economics. Soybeans in a cover crop system has resulted in economic losses **-\$21.10/A.** thus far in year two of our ten-year program.

We look forward to continuing to test the use of cover crops in a continuous bean after corn rotation and to evaluate yield and economics of the system, while taking a close look at what cover crops can offer regarding soil health improvement.

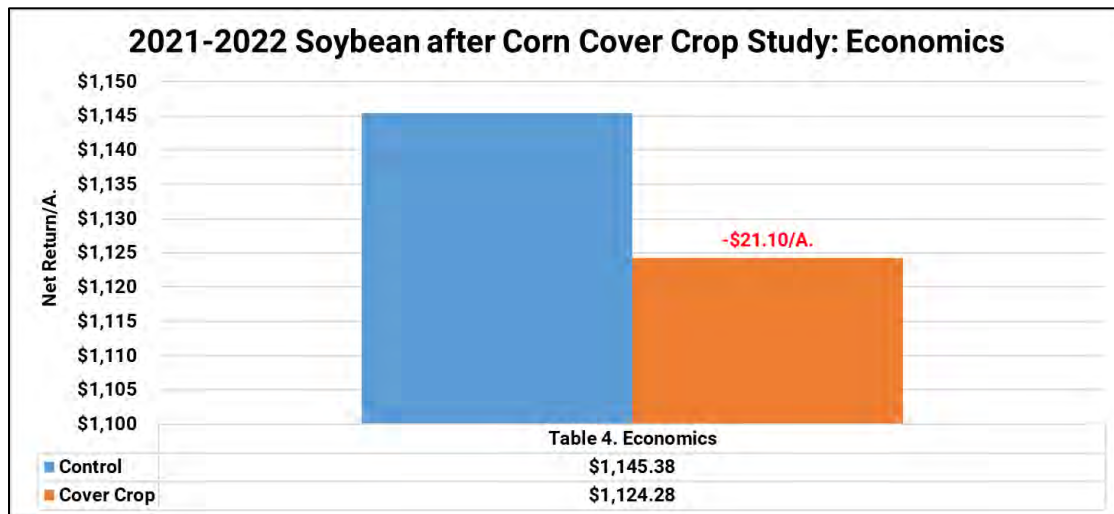
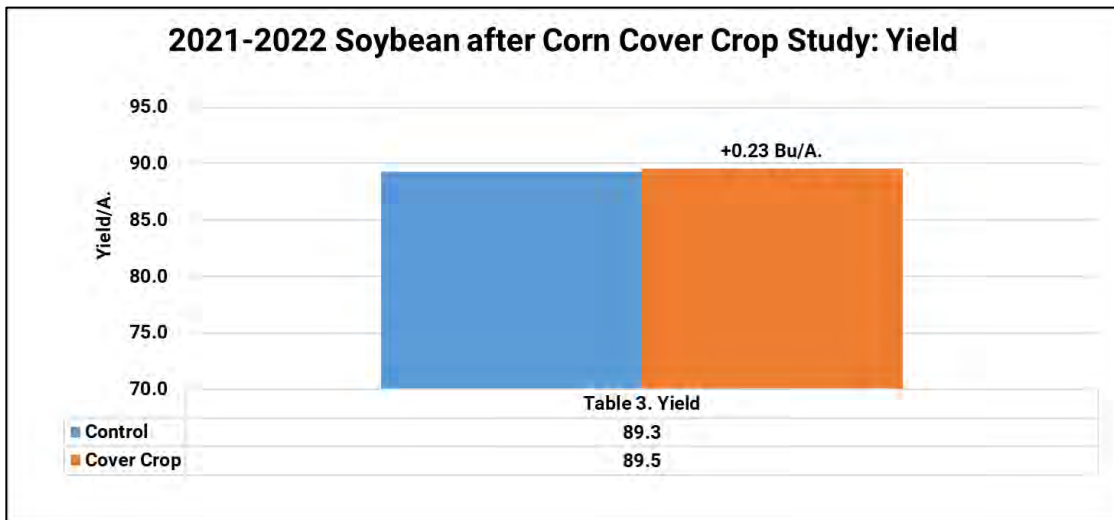

Broadcast vs Banding Dry Fertilizer Study

Objective: To evaluate yield and economics of traditional broadcast applications of dry fertilizer compared to 8" deep high concentrated strip-till banding.

Based upon soil test results and yield goals of 70 Bu/A. soybeans in a corn/soybean non-irrigated rotation, 260# 18-46-0 and 140# 0-0-60 was applied in a traditional broadcast surface application made with a traditional spinner truck (Figure 1). Using the same fertilizer rates, a strip-till bar was used to place fertilizer in high concentrated strips 8" deep on 30" corn rows (Figure 2). Corn was then planted directly into the strips above the 8" fertilizer placement. A KUHN® Krause® Gladiator® pulling a Montag® Equipment 2208 Gen 2 fertilizer cart was used to implement this testing program for 2022.

Results Table 1. illustrates strip-till fertilizer resulted in +1.4 Bu/A. yield gains over traditional broadcast applications. Soybean yield from broadcast fertilizer averaged 76.3 Bu/A., while strip-till resulted in yields of 77.7 Bu/A.

Figure 1. Broadcast Dry Fertilizer



Figure 2. Strip-Till Banded Fertilizer

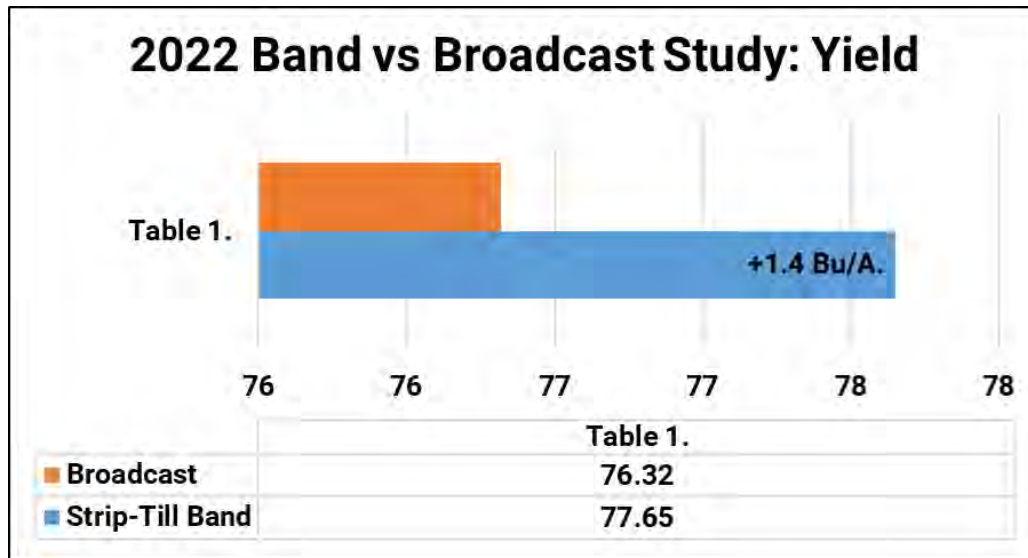

Broadcast vs Banding Dry Fertilizer Study Continued

Using University of Illinois Machinery Cost Estimates in Figure 3., strip-till resulted in additional costs of +\$9.60/A. in comparison to a conventional tillage program. Using this cost scenario, Table 2. illustrates the economic impact from our 2022 study. Strip-till, with its tillage and fertility system, posted positive economic gains of +\$9.94/A. over a conventional tillage system.

Figure 3. University of IL Machinery Cost Estimates

Tillage Practice	Category	Cost
Conventional	Soil Finisher	\$ 11.10
	Plant	\$ 17.20
	Fertilizer Spread	\$ 3.00
	Total:	\$ 31.30
Strip Till	Strip	\$ 17.30
	Plant	\$ 17.20
	Burndown	\$ 6.40
	Total:	\$ 40.90

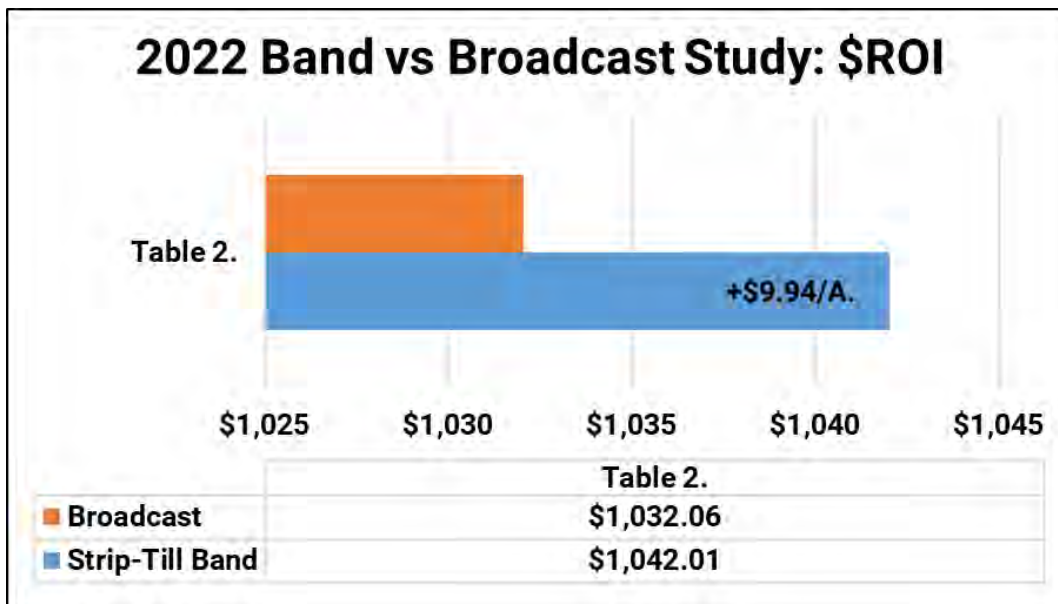

Broadcast vs Banding Rate Efficiency Study

Objective: To evaluate yield and economics of traditional broadcast applications of dry fertilizer compared to concentrated strip-till bands applied 8" in depth under the corn row.

Based upon soil test results and yield goals of 70 Bu/A. soybeans in a corn/soybean rotation, 150# of 9-23-30 was applied as a recommended fertility application from a recent soil test.

To study placement efficiency, dry fertilizer was applied in a traditional broadcast surface application as a spinner truck (Figure 1). Using the same fertilizer rates, a strip-till bar was used to place fertilizer in high concentrated strips 8" deep on 30" corn rows (Figure 2). Soybeans were then planted directly into the strips above the 8" fertilizer placement. Soybeans were also planted in a strip-till situation with the broadcast fertilizer, however as surface applied on top of the fall strips. A KUHN® Krause® Gladiator® pulling a Montag® Equipment 2208 Gen 2 fertilizer cart was used to implement this testing program for 2022.

To then study rate efficiency, fertilizer was applied at the following rate structure in both strip-till bands and broadcast applications:

- ✓ 100% Fertilizer Rate
- ✓ 75% Fertilizer Rate
- ✓ 50% Fertilizer Rate
- ✓ 25% Fertilizer Rate
- ✓ 0# Rate

Figure 1. Broadcast Dry Fertilizer



Figure 2. Strip-Till Banded Fertilizer with Montag® cart



Figure 3. KUHN Krause strip-till unit



Broadcast vs Banding Rate Efficiency Study Continued

Results: Table 1. illustrates the net return of each fertilizer rate and placement. High concentrated bands of fertilizer surpassed broadcast spreading yields at every individual rate%. 100% bands provided a +\$9.94/A. advantage, 75% +\$9.94/A., 50% +\$18.32/A., and 25% at +\$7.15/A.

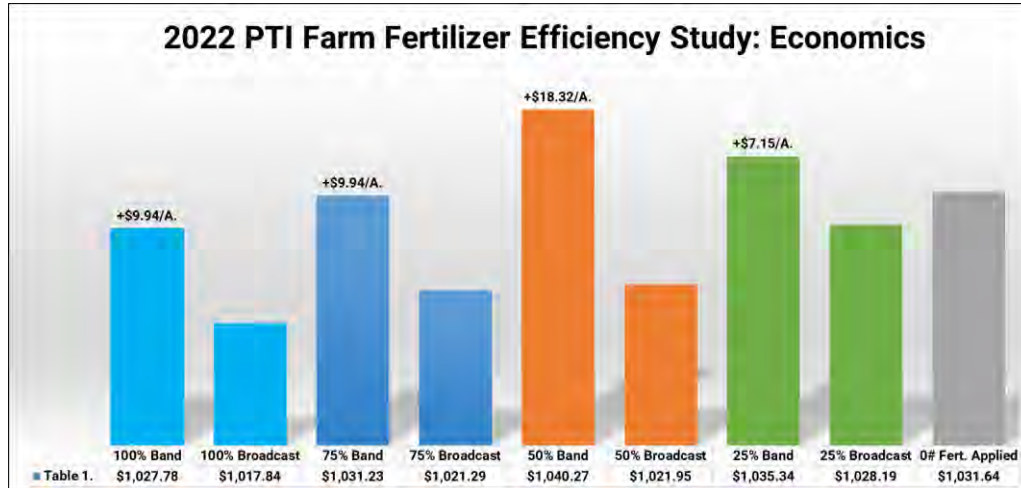
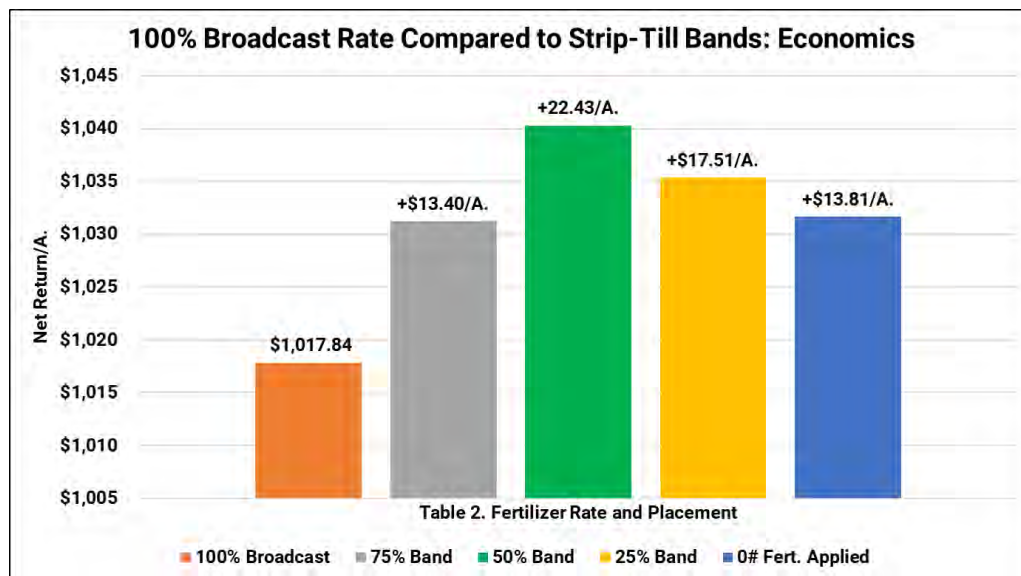

Table 2. tells the story well, as it reveals that all three banded rates of fertilizer resulted in more revenue than the 100% broadcasted rate. Lowering fertilizer to 75% rate in bands proved +\$13.40/A. additional net revenue, 50% banded rates at +\$22.43/A. and 25% banded rates offered gains of +\$17.51/A. Even applying 0# fertilizer, resulted in gains of \$13.81/A.



Broadcast vs Banding Rate Efficiency Study Continued

Table 3. illustrates a scenario using 2022 soybean yield by fertilizer rate, however, assumes a 50% cost reduction of DAP and Potash for the study. Since farmers are battling historical high prices of fertilizer today, we thought it would be interesting to see if fertilizer response would pay for itself assuming fertilizer prices would decrease by 50% and get back to somewhat normal prices paid by growers in the past?

Using a 50% fertilizer cost reduction to take DAP and potash to \$355 and \$308/Ton, 75% and 50% reduced rates of fertilizer still offered positive return on investment of +\$7.48 to +\$10.60/A. compared to 100% broadcast rates of dry fertilizer.

However, as fertilizer rates were reduced to only 25%, net losses of **-\$0.23/A.** occurred and 100% rates of fertilizer were now more effective. Shutting the fertilizer down and applying 0#/A. resulted in net losses of **-\$9.85/A.**

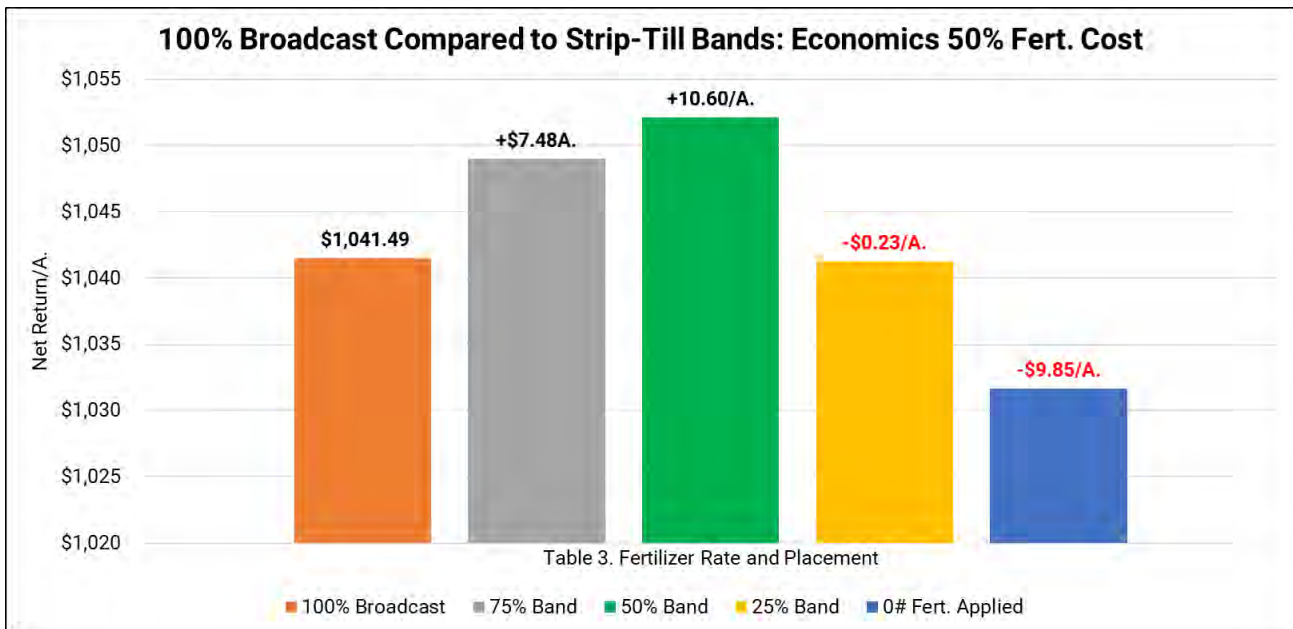

Calcium Products™ 98G® Pell Lime Study:



Objective: This trial evaluates the yield response and economics of pelletized limestone (98G®) applied fall broadcast. Soil pH is the foundation of nutrient availability and critical to maximizing crop yield. The availability of all nutrients is impacted by soil pH levels, especially phosphorus (P).

When soil pH is below 6.0, it can reduce your yield by as much as 30%. Calcium Products' 98G® pelletized limestone is the most effective and consistent product to correct and maintain soil pH.

Change Soil pH Quickly

98G corrects soil pH faster and more completely than aglime. It is the most reactive liming material because it's made from 98% pure calcitic limestone and ground to an ultra-fine powder before it is pelletized. 98G pellets are engineered and manufactured to a specific size and hardness so that the pellets handle well and spread uniformly, yet break down in the field to change soil pH. 98G is fully reactive at about three to six months after application.

Maintain Soil pH to Consistently Maximize Yield

Once soil pH is restored, use 98G to maintain pH levels with more frequent, lower rate applications. Leaving yield on the table is unacceptable, and maintaining proper soil pH is a critical piece of good fertility management and maximizing yield.

Enjoy Application Flexibility

98G can be applied in flat-rate or variable-rate applications. It can be mixed with other dry fertilizers reducing the number of trips across the field and spread spring or fall. This flexibility means you can address soil pH when and how it works for you with the same equipment used to spread other dry fertilizers.

Soil pH has traditionally been addressed about every four years with aglime. Rather than create a pH "rollercoaster" in the field with infrequent aglime applications, 98G® can be used as part of a pH maintenance program with annual or biannual applications. 98G® is a more reactive liming material than aglime, keeping soil pH at a level to maximize yield potential (typically 6.0) year after year.

Results: 200# Fall 2021 broadcast treatments of 98G® resulted in yield gains of +2.9 Bu/A. (Table 1.), and economic gains of +\$17.28/A. Soil tests were pulled in Fall 2022 and indicated soil pH at 6.0.

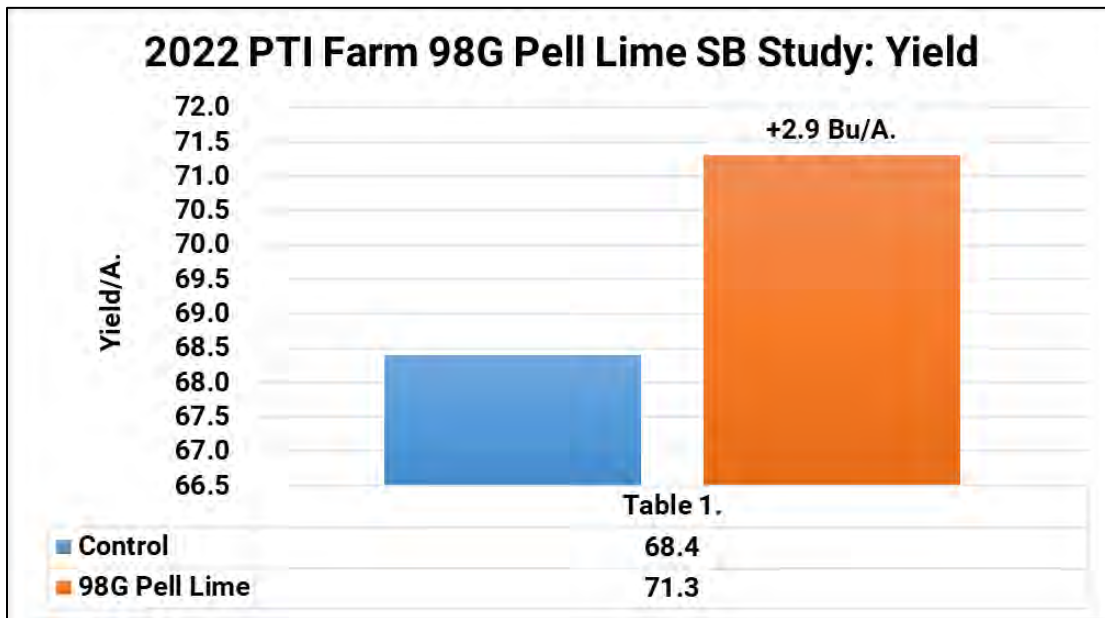

Planting Date: May 18th

Variety: Asgrow 35FX1

Population: 130K

Row Width: 30"

Rotation: BAC

Soybean Price: \$13.96

Pell Lime: \$192/Ton + \$4/A Application

Calcium Products SO4® Study

Objective: This trial evaluates the yield response and economics of pelletized calcium sulfate (SO4) applied fall broadcast and as banded spring strip-till. Sulfur is an essential component of plant growth with key processes relying on chlorophyll formation and protein production. Sulfur is considered the fourth major nutrient behind N, P, and K.



SO4® from Calcium Products is a 21% Calcium (non-pH neutralizing) and 17% Sulfur dry pelletized fertilizer and is mined and manufactured in NW Iowa. It is finely ground and pelletized to achieve a balance of solubility and pellet strength.

Historically, much of the sulfur need was satisfied with atmospheric deposition as result of coal burning industries. Amendments to the Clean Air Act in 1990 targeted sulfur emissions, resulting in less than ½ of the amount of sulfur today compared to 30 years ago.

Results: Fall 2021 broadcast treatments of SO4® resulted in average yield gains of +2.3 Bu/A. with positive net returns of +\$7.35/A.

Multi-year data from 2019-2022 have proven yield gains of +3.4, +4.9 and +2.3 Bu/A. respectively.

We look forward to continuing our long-term multi-year testing of SO4® and understanding its benefits of supplying plant nutrition, but also its effect on soil health advantages.

Releases Sulfur to Match Plant Needs

SO4 supplies a balanced initial sulfur release and a steady supply throughout the growing season. AMS releases sulfur too quickly, and elemental sulfur releases sulfur too slowly, neither meeting the crop's complete needs.

Spreads Easily

SO4's consistent pellet size allows it to be blended and applied with other dry fertilizers, which means it doesn't require a separate application. It can be applied pre-plant in the spring, in-season via top dress or post-harvest in the fall.

Will Not Acidify Soil

SO4 is pH neutral, meaning it will not acidify the soil like other sulfur sources. Proper soil pH maximizes a plant's utilization of nutrients promoting good plant health and optimizing yield.

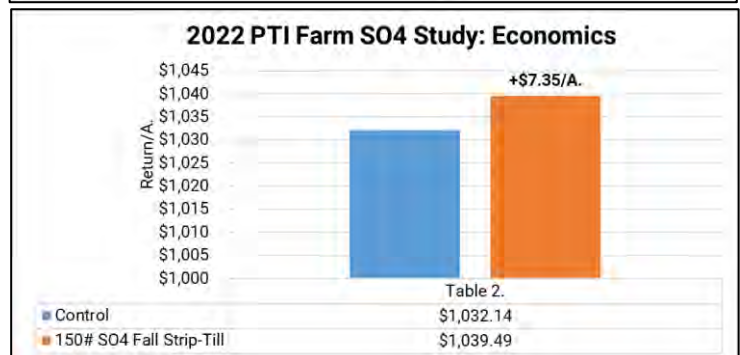
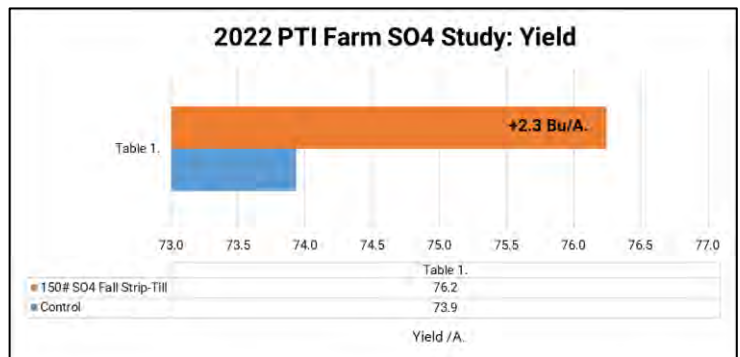

2022 High Management Soybean: NETAFIM® Irrigation Study

Objective: This study evaluates NETAFIM® drip tape irrigation designed by NutraDrip Irrigation Systems and its' ability to feed soybeans with water and nutrients for high yield potential. This method of irrigating a crop uses NETAFIM® drip tape with small pressure regulated emitters evenly spaced at 24" apart. Drip tape in this study is not sub-surface irrigation. It is rather installed on the soil surface to demonstrate how the system works, to growers who come to visit the PTI Farm. Water is accessed from a water recycling management program installed at the PTI Farm.



Results: In 2022, NETAFIM® drip tape irrigation resulted in average yield increases of +23.8 Bu/A. compared to dryland soybeans. 4.5" of water was applied through drip irrigation throughout the growing season from June - September. Fertigation was also implemented to apply Mn, Cu, B, S, N, P, and K.



Multi-Year data has proven irrigation to increase soybean yield by an average of 24.2 Bu/A., while increasing additional gross income by an average of +\$268.37/A.

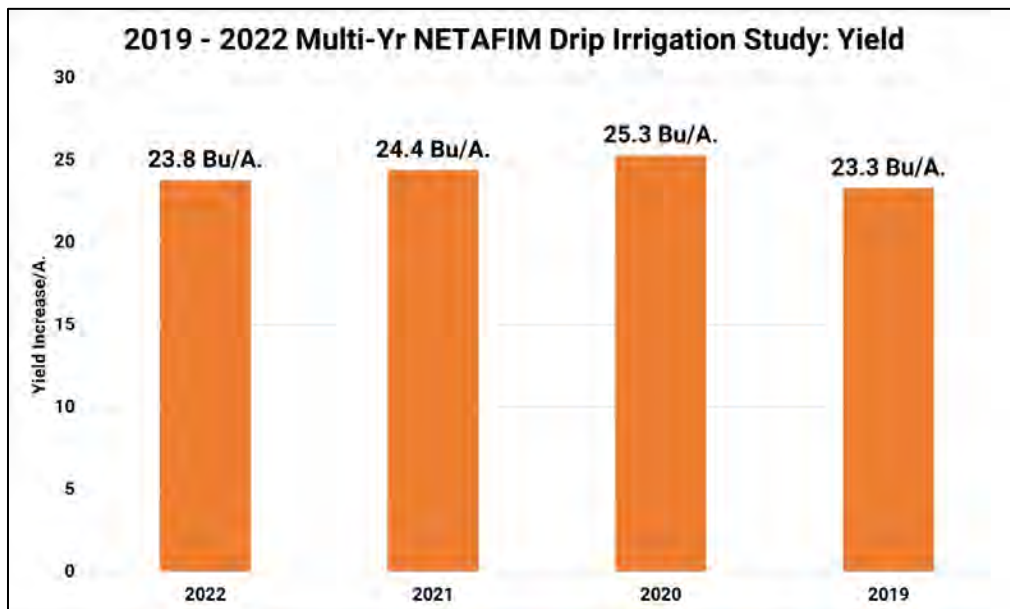

2022 High Management Soybeans: Soybean Seed Size Study

Objective: To evaluate soybean seed size in relation to high yield soybeans.

In our 2022 high management soybean trials, our PTI Team wanted to evaluate the ability to increase soybean seed size, as a result of the various treatments applied throughout the growing season. Seed samples were collected at harvest and then ran through a series of seed counting and weighting exercises to determine actual seed weight and size (Figures 1-2).

Results: Table 1. summarizes the seed size differences of a high managed, irrigated protocol compared to that of a status quo, average management, dry land protocol.

Soybean seed sizes were 452 seeds/# larger in high management treatments and also exhibited higher test weight by 1.4 #'s/Bu. More work needs to be done to fully understand soybean seed size from various management techniques, but 2022 data suggests bigger beans equates to bigger yields.

2021 data found high management soybeans at 2084 seeds/#, +781 more than low management protocols.

Test weight is a “unicorn” to understand, but current overall volumetric grading standards in soybeans usually suggest average soybeans near 57#/Bu in most cases, even though farmers are graded at 60#/Bu.

Figure 1. Large Soybean Seed Size



Table 1.

<u>Program:</u>	<u>Seed Size:</u>	<u>Test Weight:</u>
<u>Status Quo</u>	<u>2750 Seeds/#</u>	<u>57.0</u>
<u>High Management:</u>	<u>2298 Seeds/#</u>	<u>58.4</u>

Nachurs® High Management Soybean Study

Objective: To evaluate the yield and economic impact of a soybean liquid starter fertilizer and foliar nutritional program from Nachurs® in a high management irrigated environment. This trial consisted of the following:

Treatments and Placement:



#1. Control:	Irrigation, Only Foliar R3 + R5 Foliar Fungicide
#2 At-Plant Fertility:	
Conceal® Dual Band (Figure 1.)	5 Gal Nachurs Throwback®, 1Qt Nachurs Humi-Flex® Max 3 Gal K-fuse®, 0.5 Gal Nachurs SideSwipe®
FurrowJet® Center: (Figure 2.)	1Qt Rhyzo-Link® PE, 1.5 Gal Balance® 1Pt Nachurs HumiFlex® FA, 1Pt Calcium 3%
FurrowJet® Wings: (Figure 2.)	1 Gal Balance®, 2 Gal TripleOption®
#3 Foliar Applications:	
	V3: 1Qt FinishLine®, 3 Qt TripleOption®
	R1: 1 Gal Nachurs K-flex®, 1 Gal Nachurs imPulse®, 1Pt Nachurs Finishline®
	R1: 8oz Boron 10%, 2oz Moly
	R3: 2 Qt Nachurs K-fuel®, 1.5 Gal Balance®
	

Figure 1. Conceal Placement



Figure 2. FurrowJet® Placement

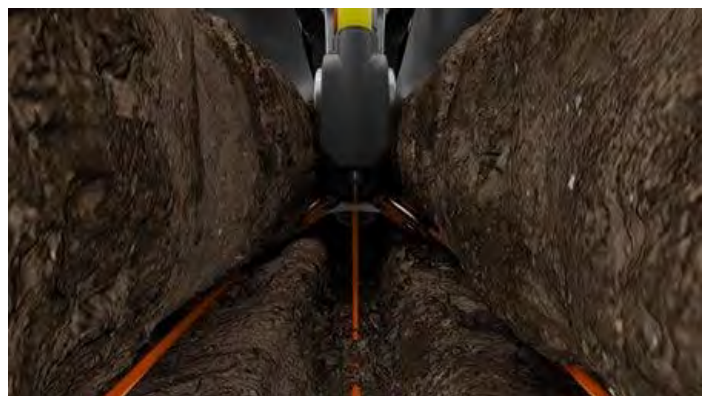

Nachurs® High Management Study Continued

Irrigation on all treatments (excluding control) received 5" of rain throughout the growing season. All treatments (including control) received 13.7oz/A. of Miravis® Neo at R1 and 13.7oz/A. of TrivaPro® at R3 growth stages.

Results: The table below illustrates control treatments averaging 87.5 Bu/A. At-plant treatments achieved 97.0 Bu/A., +9.5 Bu/A. over the control. At-plant + foliar treatments offered yields of 101.0 Bu/A., +13.5 Bu/A. gains over the control and +4.0 Bu/A. over the stand-alone at-plant treatments.

Economics indicate at-plant treatments resulted in gains of +\$47.64/A., while full combination treatments gained positive returns of +\$66.06/A.

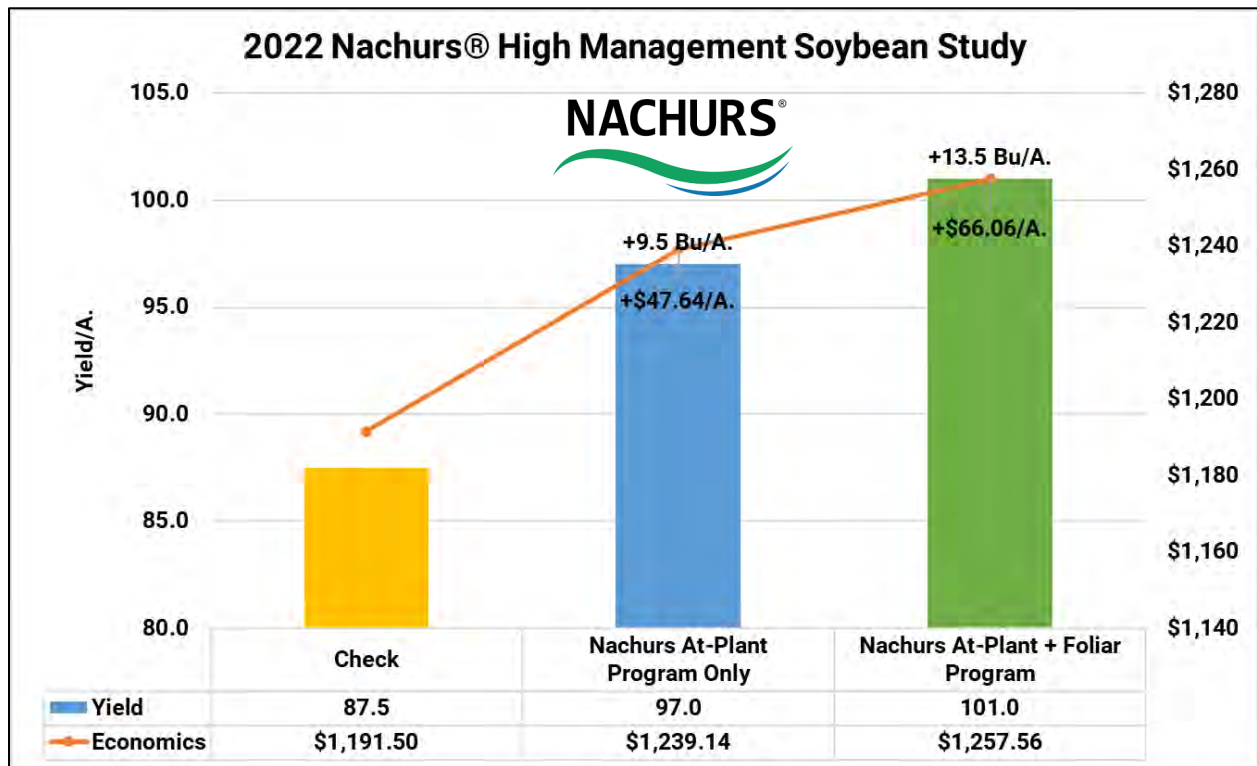

Planting Date: May 5th Variety: Golden Harvest® 3244XF Population: 120K Row Width: 30" Rotation: BAC SB Price: \$13.96

FurrowJet®: \$40.88/A Conceal® Program: \$74.10/A. Foliar Program: \$37.43/A. Fert Reallocation: \$30/A.

AgroLiquid® High Management Soybean Study

Objective: To evaluate the yield and economic impact of a corn liquid starter fertilizer and foliar nutritional program from AgroLiquid in a high management irrigated environment. This trial consisted of the following:

Treatments and Placement:

Control:	Irrigation, Foliar R3 Foliar Fungicide
At-Plant Fertility:	
FurrowJet® Tri-Band: (Figure 1.)	1 Gal/A. Sure-K® 1Qt/A. Micro500™ 1 Gal/A. SpringUp®
Foliar Applications:	
	V4: 1 Pt/A. Boron
	R1: 1.5 Gal/A. Kapitalize® + 1.5 Gal/A. FertiRain® + 1Pt/A. Manganese
	R3: 1.5 Gal/A. Kapitalize® + 1.5 Gal/A. FertiRain® + 1Pt/A. Manganese

Figure 1. FurrowJet® Placement



AgroLiquid® High Management Soybean Study

Irrigation on all treatments (including control) received 5.0" rain throughout the growing season. All treatments received 13.7oz/A. of Miravis® Neo at R1 and 13.7oz/A. of Trivapro® at R3 growth stages.

Results: The table below illustrates control treatments averaging 87.5 Bu/A. At-plant treatments achieved 91.4 Bu/A., +3.9 Bu/A. over the control. At-plant + foliar treatments offered yields of 97.8 Bu/A., +10.3 Bu/A. gains over the control and +6.4 Bu/A. over the stand-alone at-plant treatments.

Economics indicate at-plant treatments resulted in gains of +\$65.03/A., while full combination treatments gained positive returns of +\$90.38/A.

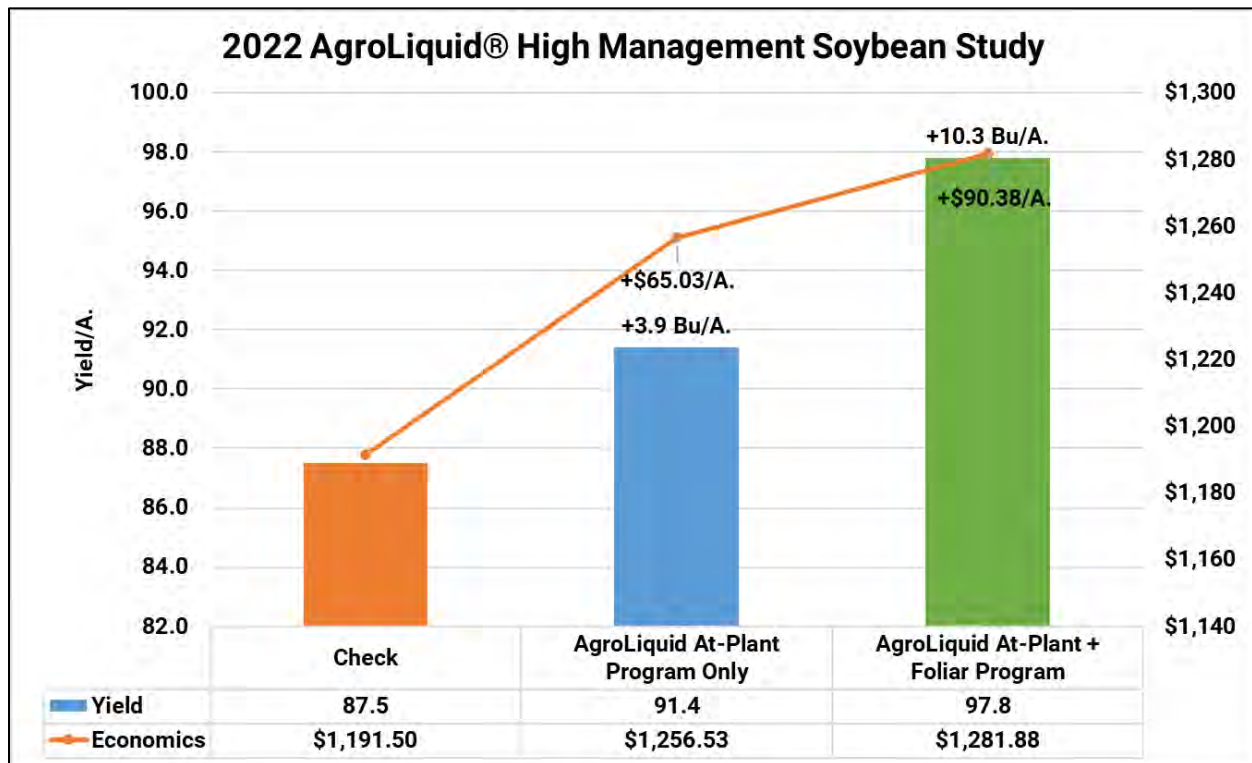

Planting Date: May 5th Variety: Golden Harvest® 3244XF Population: 120K Row Width: 30" Rotation: BAC SB Price: \$13.96

FurrowJet®: \$19.41/A Foliar Program: \$64.00/A. Fert Reallocation: \$30/A.

The Anderson's® High Management Soybean Study

Objective: To evaluate the yield and economic impact of a soybean liquid starter fertilizer and foliar nutritional program from The Andersons in a high management irrigated environment. This trial consisted of the following:

Treatments and Placement:

#1. Control:	No Irrigation, Only Foliar VT + R3 Foliar Fungicide
#2 At-Plant Fertility:	
Conceal® Dual Band (Figure 1.)	5 Gal/A. 32% UAN, 15 Gal/A. 14-12-4-6, 2Pt/A. SB Mix 11 64oz/A. Korrekt® Plus, 1 Gal/A. UltraMate™
FurrowJet® Center: (Figure 2.)	1.5 Gal/A. First Pass® with MicroCarb® + 1Pt/A. BioPass™
FurrowJet® Wings: (Figure 2.)	1.5 Gal/A. First Pass® with MicroCarb® + 5 Gal/A. water
#3 Foliar Applications:	V3: 1Pt/A. PhosFix®, 1Qt/A. MicroBlitz®, 16oz/A. SweetNEezy™ R1: 1Qt/A. MicroBlitz®, 16oz/A. Eezy® Moly-B R3: 1 Gal/A. OverPass® 10-2-10, 1 Gal/A. Korrekt® Plus™, 16oz/A. SweetNEezy™ R5: 1 Gal/A. OverPass® 10-2-10, 1 Gal/A. Korrekt® Plus™, 16oz/A. SweetNEezy™



Figure 1. Conceal Placement



Figure 2. FurrowJet® Placement



The Anderson's® High Management Soybean Study Continued

Irrigation on all treatments received 5.0" Rain throughout the growing season, as well 13.7oz/A. of Miravis® Neo at R1 and 13.7oz/A. of Trivapro® at R3 growth stages.

Results: At-Plant treatments resulted in yields of 96.4 Bu/A., +8.9 Bu/A. over the control. At-plant in-addition to foliar combination treatments pushed yield over the century mark to 100.5 Bu/A., +13.0 Bu/A. over the control.

After all costs, at-plant nutritional treatments proved economic gains of +\$20.69/A., while adding the foliar treatments resulted in gains of +\$18.51/A.

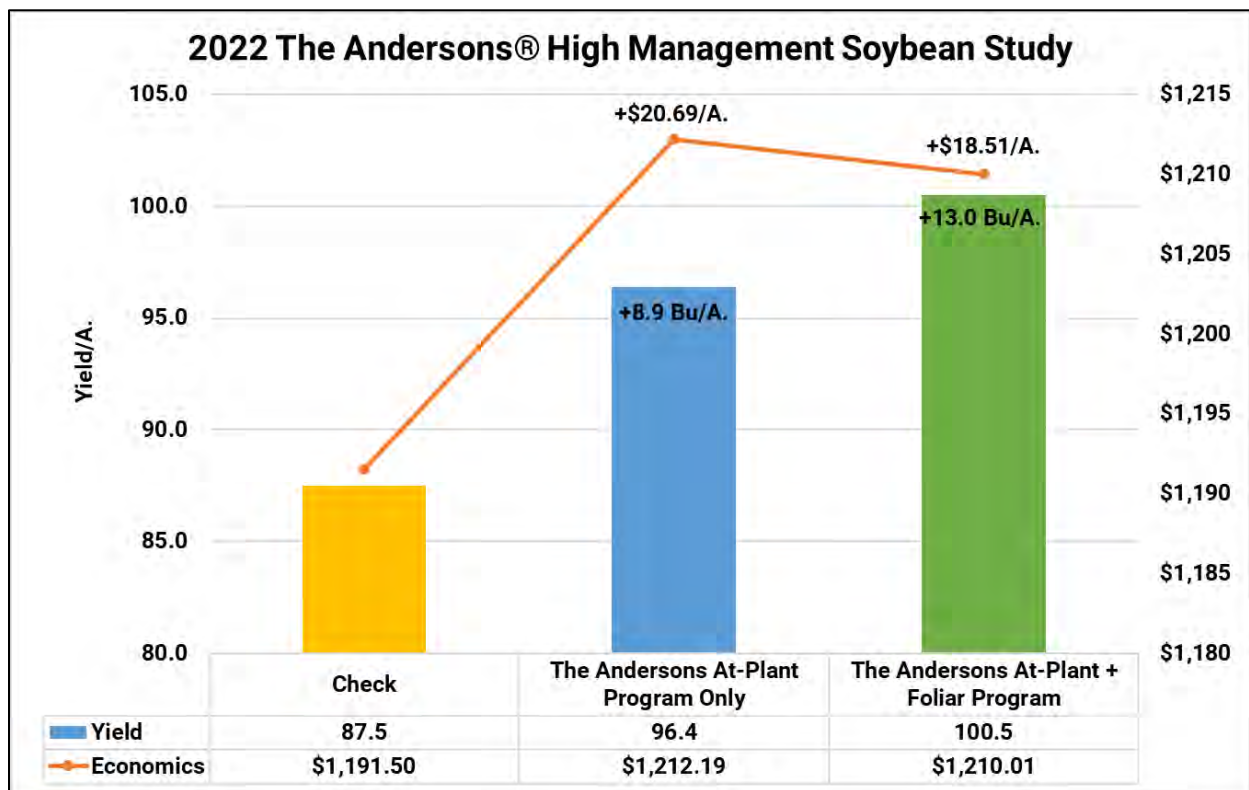

Planting Date: May 5th Variety Golden Harvest® 3244XF Population: 120K Row Width: 30" Rotation: BAC SB Price: \$13.96

FurrowJet® Center: \$22.22/A FurrowJet® Wings: \$11.93/A Conceal® Program: \$99.40/A Foliar Program: \$59.42/A Fert Reallocation: \$30/A.

Marco Fertilizer High Management Soybean Study

Objective: To evaluate the yield and economic impact of a soybean liquid starter fertilizer and foliar nutritional program from Marco Fertilizer in a high management irrigated environment. This trial consisted of the following:

Treatments and Placement:

#1. Control:	Irrigation + R1 and R3 Foliar Fungicide
#2 At-Plant Fertility:	
Conceal® Dual Band (Figure 1.)	15 Gal/A. BOOST 14-12-14-6S
FurrowJet® Center: (Figure 2.)	12.8oz TerraMax MicroAZ-IF Liquid™ Inoculant
FurrowJet® Wings: (Figure 2.)	3 Gal/A. NutriStart Complete
	3 Gal/A. Water
#3 Foliar Applications:	
	V4: 1# NutriComplete 8-12-40
	R1: 1# NutriComplete 8-12-40
	R3: 1# NutriComplete 8-12-40

Figure 1. Conceal Placement



Figure 2. FurrowJet® Placement

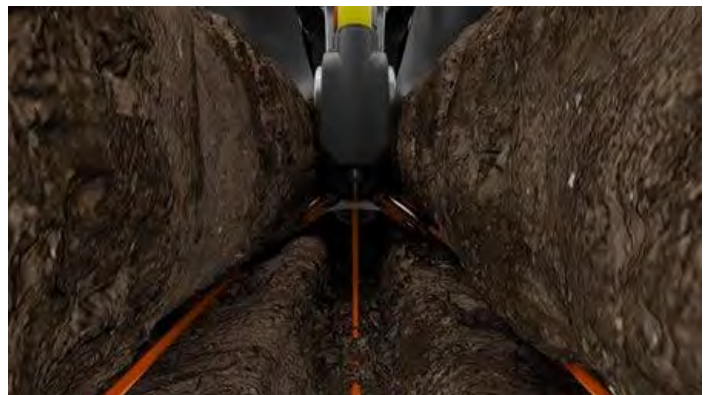

Marco Fertilizer High Management Soybean Study Continued

All treatments received 5.00" of rain throughout the growing season as well as fungicide applications of 13.7oz/A. Miravis® Neo at R1 and 13.7oz/A. of Trivapro® at R3 growth stages.

Results: At-Plant treatments resulted in yields of 92.9 Bu/A., +5.4 Bu/A. over the control. At-plant + foliar combination treatments pushed yield to 98.7 Bu/A., +11.2 Bu/A. over the control.

After all costs, at-plant nutritional treatments proved economic gains of +\$7.58/A. Foliar treatments tallied some of the lowest costs (\$15/A.) in all the high yield soybean trials and resulted in gains of +\$73.55/A.

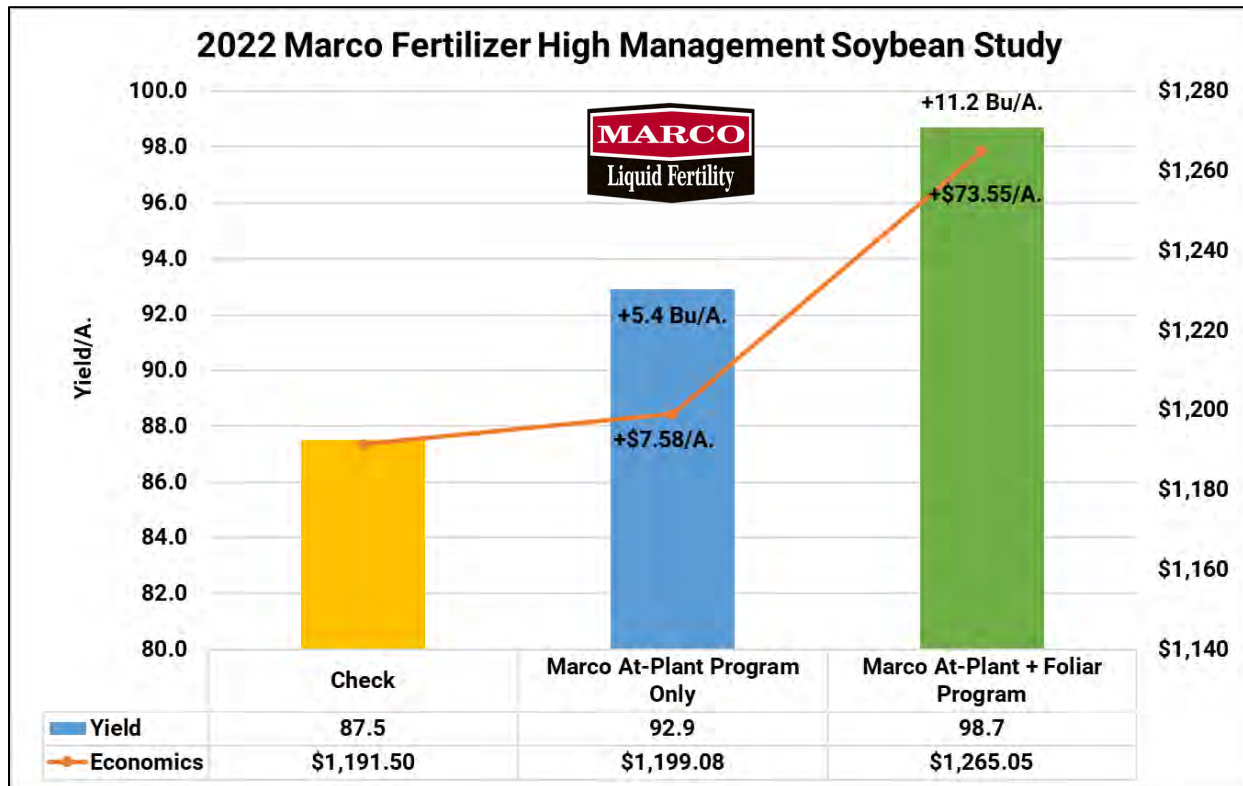

Planting Date: May 5th Variety Golden Harvest® 3244XF Population: 120K Row Width: 30" Rotation: BAC SB Price: \$13.96

FurrowJet® Center: \$4.80/A FurrowJet® Wings: \$29.25/A Conceal® Program: \$63.75/A Foliar Program: \$15/A Fert Reallocation: \$30/A

Stoller® USA Fertilizer High Management Soybean Study

Objective: To evaluate the yield and economic impact of a soybean liquid starter fertilizer and foliar nutritional program from StollerUSA in a high management irrigated environment. This trial consisted of the following:

Treatments and Placement:

#1. Control:	Irrigation, R1 + R3 Foliar Fungicide
#2 At-Plant Fertility:	
Seed Treatment:	2oz/A. Bio-Forge® Premier
FurrowJet® Center: (Figure 2.)	4oz/A. Fortified Stimulate Yield Enhancer® + 1Qt/A. Charge 12%™
FurrowJet® Wings: (Figure 2.)	1Qt/A. Harvest Plus™
#3 Foliar Applications:	
	V4: 8oz Xcyte™, 8oz Bio-Forge® Advanced
	R1: 1Qt/A. Sugar Mover® Premier, 8oz/A. Xcyte™
	R2: 16oz Xcyte™, 2.5#/A. Harvest More UreaMate®, 1 Qt/A. Sugar Mover®
	R3: 16oz/A. Xcyte™, 2.5#/A. Harvest More® UreaMate
	R4: 1 Qt/A. Sugar Mover®, 12oz/A. Xcyte, 2.5# Harvest More® Urea Mate
	R5: 2.5#/A. Harvest More® Urea Mate
R6: 1Pt/A. Force	

Figure 1. FurrowJet® Placement



Stoller USA Fertilizer High Management Soybean Continued

All treatments received 5.00" of rain throughout the growing season as well as fungicide applications of 13.7oz/A. Miravis® Neo at R1 and 13.7oz/A. of TrivaPro® at R3 growth stages.

Results: At-Plant treatments resulted in yields of 91.2 Bu/A., +3.7 Bu/A. over the control. At-plant + foliar combination treatments pushed yield to 100.1 Bu/A., +12.6 Bu/A. over the control.

After all costs, at-plant nutritional treatments proved economic gains of +\$62.11/A. The foliar at-plant combination treatments tallied yield gains of +12.6 Bu/A. with positive economic returns of +\$66.51/A.

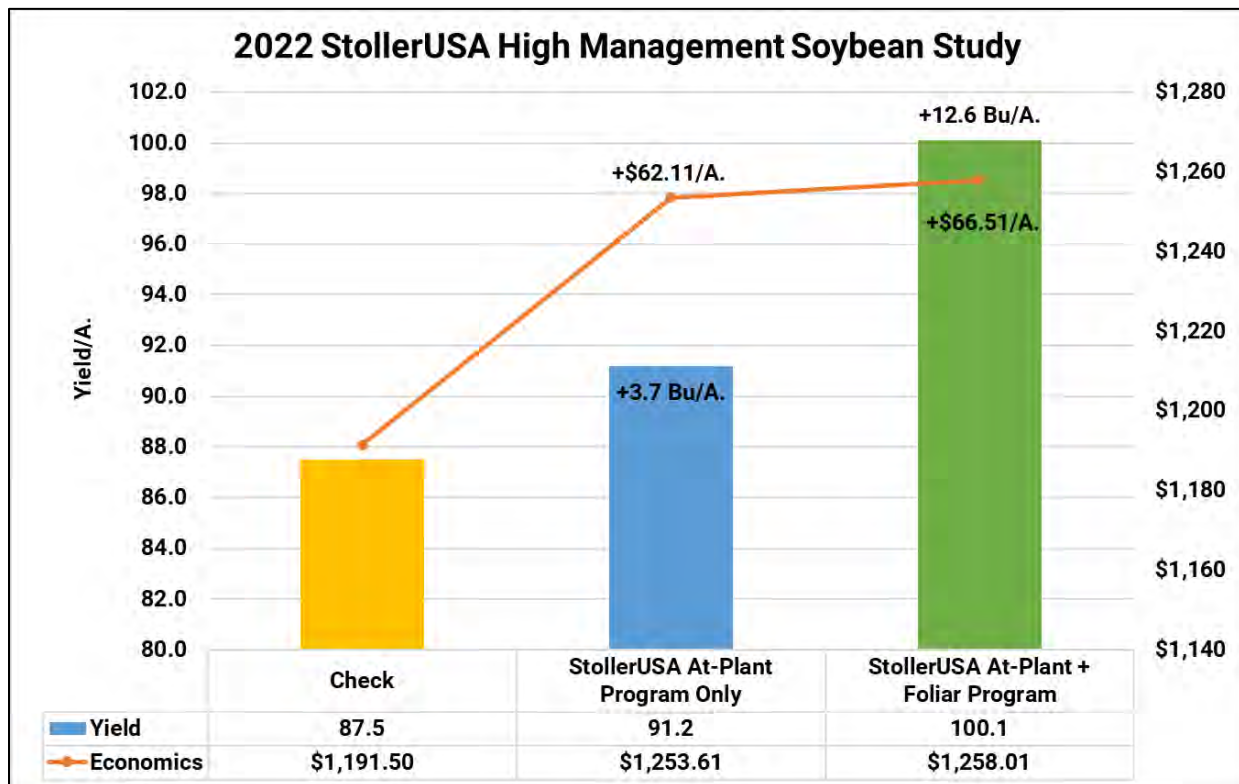

Planting Date: May 5th Variety Golden Harvest® 3244XF Population: 120K Row Width: 30" Rotation: BAC SB Price: \$13.96

FurrowJet® Center: \$13.03./A FurrowJet® Wings: \$6.51/A. Foliar Program: \$119.85/A. Fert Reallocation: \$30/A.

Brandt® Fertilizer High Management Soybean Study

Objective: To evaluate the yield and economic impact of a soybean liquid starter fertilizer and foliar nutritional program from Brandt in a high management irrigated environment. This trial consisted of the following:

Treatments and Placement:

#1. Control:	Irrigation, R1 + R3 Foliar Fungicide
#2 At-Plant Fertility: Conceal® Dual Band (Figure 1.)	5 Gal/A. Brandt® 5-12-0 1Qt/A. Brandt® Uptake® Starter 1Qt/A. Brandt® EnzUp® 2 Qt/A. Brandt® Liquid Boron (10%)
#3 Foliar Applications: 	V3: 1Pt/A. Brandt® Sulfur Plus™ R1: 2 Qt/A. Brandt® Smart KB VT: 13.7oz Miravis® Neo + 1Qt/A. Brandt® Smart KB R3: 1Qt/A. Brandt® Smart KB + 1Qt/A Brandt® Smart Trio®

Figure 1. Conceal Placement



Brandt® High Management Soybean Study Continued

All treatments received 5.00" of rain throughout the growing season as well as fungicide applications of 13.7oz/A. Miravis® Neo at R1 and 13.7oz/A. of TrivaPro® at R3 growth stages.

Results: At-Plant treatments resulted in yields of 89.5 Bu/A., +5.4 Bu/A. over the control. At-plant + foliar combination treatments yielded 90.1 Bu/A., +6.0 Bu/A. over the control.

After all costs, at-plant nutritional treatments proved economic gains of +\$40.73/A. The foliar at-plant combination treatments tallied positive economic returns of +\$30.51/A.

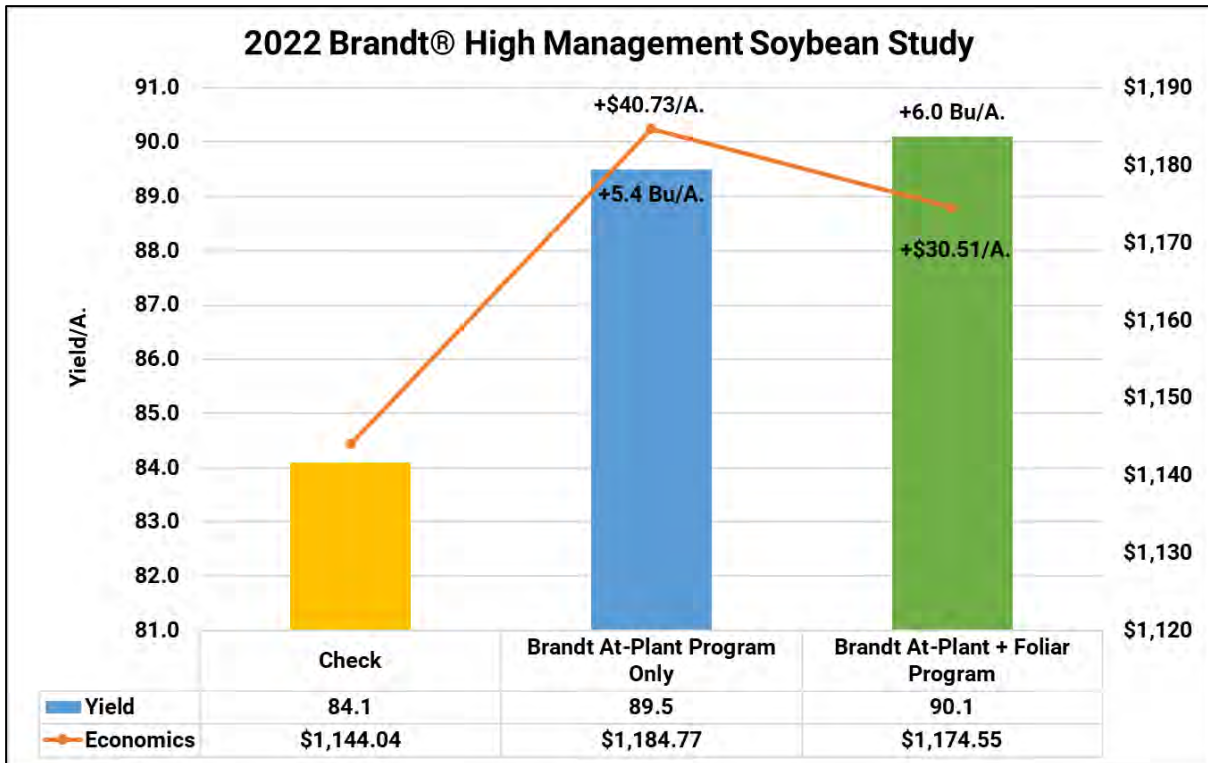

Planting Date: May 5th Variety Golden Harvest 3244XF Population: 120K Row Width: 30" Rotation: BAC SB Price: \$13.96

FurrowJet®: \$64.65/A Foliar Program: \$18.60/A. Fert Reallocation: \$30/A.

Ocean Blue Ag Soybean High Management Study

Objective: To evaluate the yield and economics of Ocean Blue Ag’s soybean nutrition program. This high management fertility study implements the use pre-plant dry calcium, sea salt, at-plant FurrowJet® and Conceal® liquid nutrition, as well as foliar liquid applications at V3, VT, and R1 growth stages.

SandyCal by Calcean, is a 94-98% pure calcium carbonate and is applied as a broadcast pre-plant and is raw natural aragonite sand mine from the ocean near the beaches of the Bahamas.

Sea-90™ by SeaAgri, Inc are natural salt crystals produced from sea water mined from the Sea of Cortez in Mexico. It is dehydrated seawater in its purest state containing 75-80 percent sodium chloride containing 90 plus elements including sodium, potassium, calcium, and magnesium and balanced with trace elements including copper, chromium, zinc, manganese, selenium, cobalt, molybdenum.

Elevation 0-5-0 is an early V3 foliar feed that contains long lasting bio-stimulated catalyst and phosphoric acid that helps pollination, blossom retention and fruiting.

Grain Gain 0-5-0 is a VT foliar feed that is a reproductive energizer and catalyst that improve test weight, insect and disease resistance and better grain fill.

Nutri-Shield 0-7-0 is applied in-furrow and contains vitamin hormone enzymes, rooting acids, chelated trace minerals, and humic acids. It helps provide for immediate growth energy, promotes stronger roots and suppresses insect feeding.

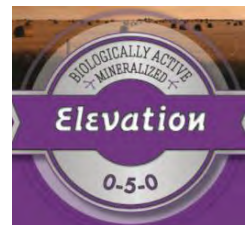

Ocean Blue Ag Fertility High Management Study

The following treatments were made as a part of a sequential step-up program to help evaluate single applied programs as well as combination programs:

<u>Program</u>	<u>Treatment</u>	<u>Application Timing</u>	<u>Placement of Fertilizer</u>
1	Control	None	None
2	400# Aragonite	Pre-Plant	Broadcast Spinner
3	75# Sea-90®	Pre-Plant	Broadcast Spinner
4	80oz Nutri-Shield FurrowJet® 64oz Elevation 1 Gal GrainGain	At-Plant In-Furrow V4 R1	FurrowJet® Tri-Band Foliar Broadcast Spray Foliar Broadcast Spray
5	80oz Nutri-Shield FurrowJet® 64oz Elevation 1 Gal GrainGain	At-Plant In-Furrow V4,V8 R1,R3	FurrowJet® Tri-Band Foliar Broadcast Spray Foliar Broadcast Spray
6	Program #5 + Aragonite	Pre-Plant At-Plant In-Furrow V4,V8 R1,R3	Broadcast Spinner FurrowJet® Tri-Band Foliar Broadcast Spray Foliar Broadcast Spray
7	Programs #2, #3, and #5	Pre-Plant Pre-Plant At-Plant In-Furrow V4 R1,R3	Broadcast Spinner Broadcast Spinner FurrowJet® Tri-Band Foliar Broadcast Spray Foliar Broadcast Spray

*All treatments received foliar treatment of fungicide at R3 growth stage.

Ocean Blue Ag Fertility High Management Study Continued

Results: Table 1. Summarizes all Ocean Blue Ag products proved positive yield gains ranging from +2.3 to +4.9 Bu/A. Full combination treatments offered highest yields at +4.8 to +4.9 Bu/A.

Table 2. illustrates the telling story around the economics of the treatments. While all treatments provided positive yield gains, only three treatments proved positive net returns.

Dry broadcast treatments of Sandy Cal aragonite and Sea-90 proved net revenue gains of +\$34.44/A. and +\$44.91/A.

FurrowJet® and single foliar treatments of Elevation and Grain Gain proved positive net gains of +\$6.05/A.

Combination treatments, although highest yields, proved losses of **-\$13.05/A.**, **-\$26.77/A.** and **-\$50.94/A.** respectively.

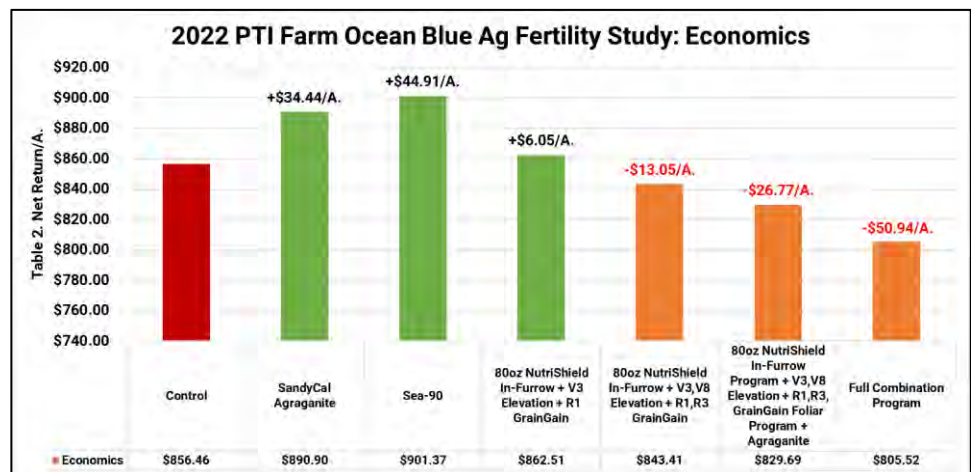
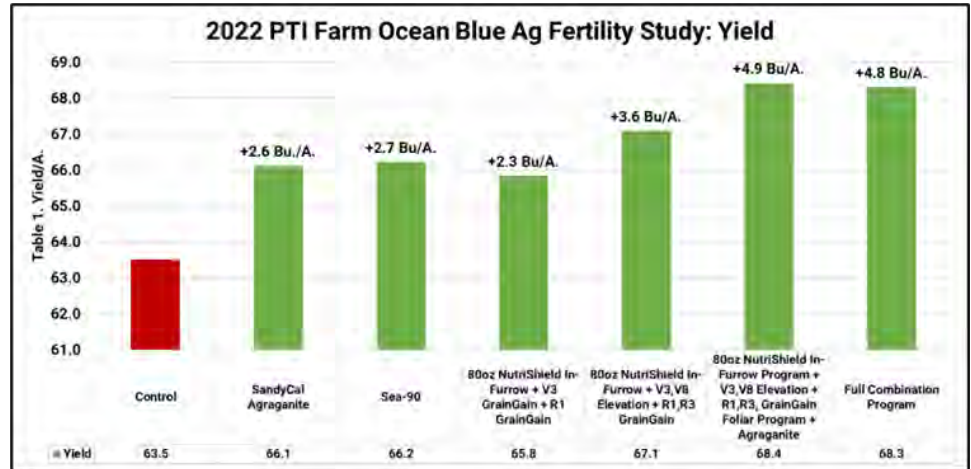

Planting Date: May 18th Variety: GH 3192XF Population: 120K Row Width: 30" Rotation: CAB SB Price: \$13.96 \$30 Fertilizer Reallocation

SandyCal Aragonite: \$31.86/A. NutriShield: \$18.81/A Grain Gain: \$22.20/A. Elevation: \$15.05/A. Sea-90: \$22.78/A.

Stoller®USA FurrowJet® Study

Objective: This soil engaging fertility application trial evaluates the yield and net return of Stoller®USA’s Bio-Forge® Advanced applied in a FurrowJet® center treatment and Charge 12%™, Fortified Stimulate, and Harvest Plus™ applied in FurrowJet® wings (Figure 1).

Bio-Forge® Advanced is an abiotic stress mitigator in plants. It does so by facilitating greater uptake and utilization (metabolism) of key nutrients, like nitrogen, from available resources including soil-bound nutrients.

Charge 12%™ is an organic humic acid that improves nutrient utilization, root development, and soil aggregation. It is OMRI Listed for use in organic production.

Fortified Stimulate Yield Enhancer® Plus is an EPA registered plant bio stimulant that has four growth hormones in a formulation that promotes plant growth and optimizes essential plant functions. Also contains the hormone IAA (indole acetic acid) which is critical for optimizing fast vigorous root growth.

Harvest Plus™ is a premium liquid fertilizer that provides season-long plant nutrition through a proprietary formulation of essential macro and micronutrients. Harvest Plus™ prevents or corrects micronutrient deficiencies in corn, soybeans, and other food and fiber crops with similar nutritional requirements.

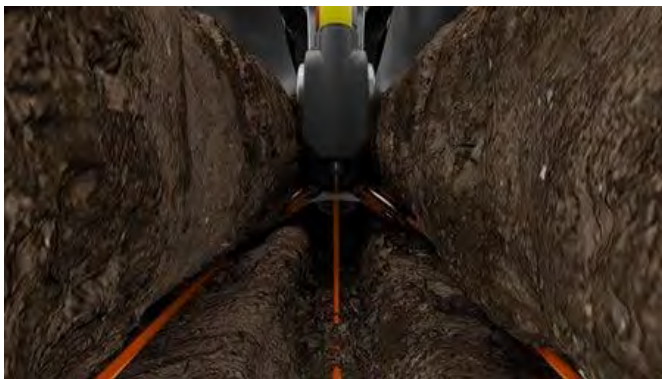

Figure 1. FurrowJet® Placement

Bio-Forge® Advanced
3-0-1

GUARANTEED ANALYSIS

Total Nitrogen (N).....	3%
1.25% Urea Nitrogen	
1.75% Other Water Soluble Nitrogen	
Soluble Potash (K ₂ O).....	1%
Cobalt (Co).....	1%
1% Chelated Cobalt (Co)	
Molybdenum (Mo).....	1%

Charge 12%

CONTAINS NON-PLANT FOOD INGREDIENT(S):

GUARANTEED ANALYSIS:

Soil Amending/Active Ingredient(s):	
Humic Acids (from Leonardite)	12%
Total Other/Inert Ingredient(s): (aqueous solution).....	88%

**Fortified Stimulate®
Yield Enhancer Plus**

ACTIVE INGREDIENTS:

Cytokinin (as kinetin)	0.009%
Gibberellic acid	0.005%
Indole-3-butyric acid	0.005%
Indole-3-acetic acid	0.005%
OTHER INGREDIENTS:	99.976%
Total	100.000%

Harvest Plus™
8-0-0

GUARANTEED ANALYSIS

Total Nitrogen (N).....	8%
8% Ammoniacal Nitrogen	
Sulfur (S).....	3%
3% Combined Sulfur	
Boron (B).....	0.25%
Manganese (Mn).....	3%
3% Chelated Manganese	
Zinc (Zn).....	3%
3% Chelated Zinc	

Stoller®USA FurrowJet® Study Continued

Results:

FurrowJet® center treatments resulted in yield gains of +1.3 Bu/A. with associated positive net returns of +\$13.90/A. Wing applications of Fortified Stimulate, Charge, and Harvest Plus™ contribute minimal gains of +0.8 Bu/A. and consequently suffered losses of **-\$7.38/A.** However, the highest yield response in this study consisted of the combination application, resulting in +4.1 Bu/A. yield increases with a positive return on investment of +\$34.44/A.

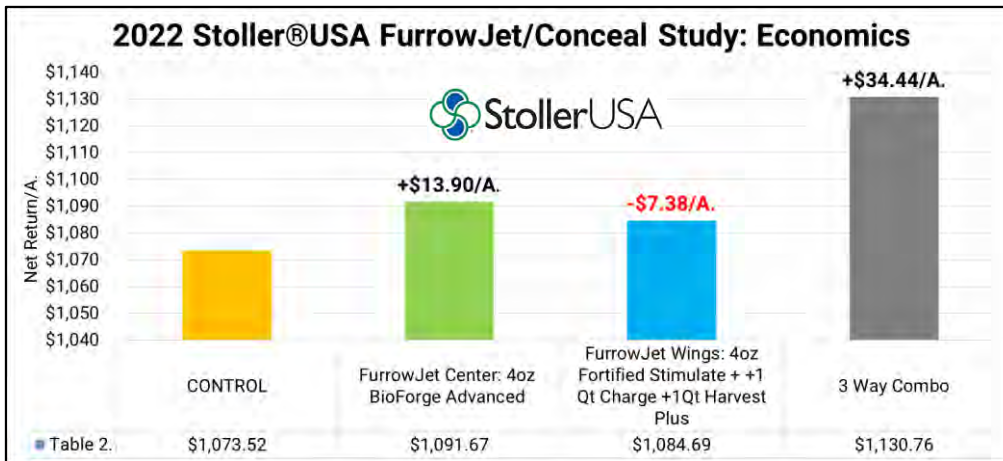
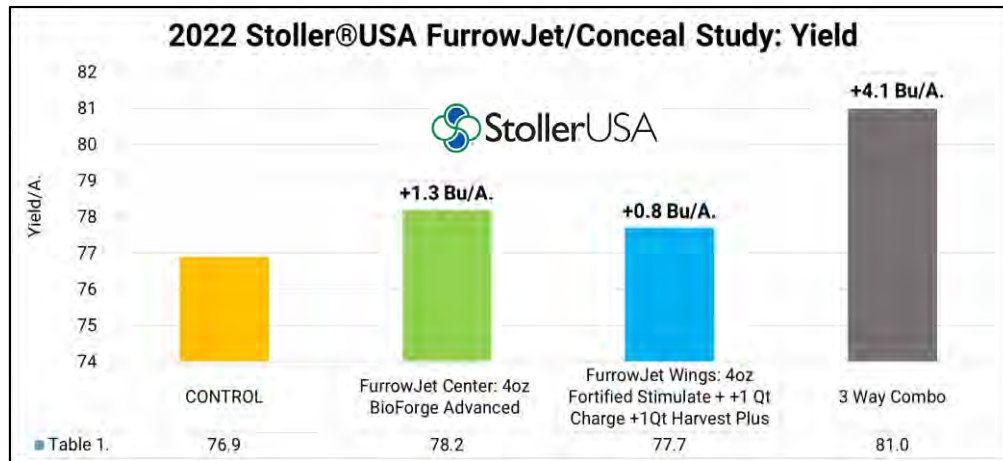

Planting Date: May 18th Variety: Asgrow® 35XF1 Population: 130K Row Width: 30" Rotation: BAC SB Price: \$13.96

BioForge Advanced: \$4.25/A. Charge: \$5.58/A. Harvest Plus™: \$6.51/A. Fortified Stimulate: \$6.46/A.

Marco QuickGrow LTE FurrowJet® Study

Objective: To evaluate the yield and net return of Marco Fertilizer’s QuickGrow LTE 6-20-4-.25Zn-2.7S liquid starter fertilizer. QuickGrow LTE is a 70% polyphosphate and 30% orthophosphate formulation of nitrogen, phosphorus, potassium, sulfur, and EDTA Zn. Marco LTE starter treatments are applied at 4, 6 and 8Gal/A. as a FurrowJet® *wing* treatment only (Figure 1 & 2).

Results: 6 Gal/A. rates showed both agronomic and economic optimum rate with yield gains of +2.4 Bu/A. and a return on investment of +\$32.90/A. (Tables 1-2).

Figure 1. FurrowJet®



Figure 2. FurrowJet® Wing Placement

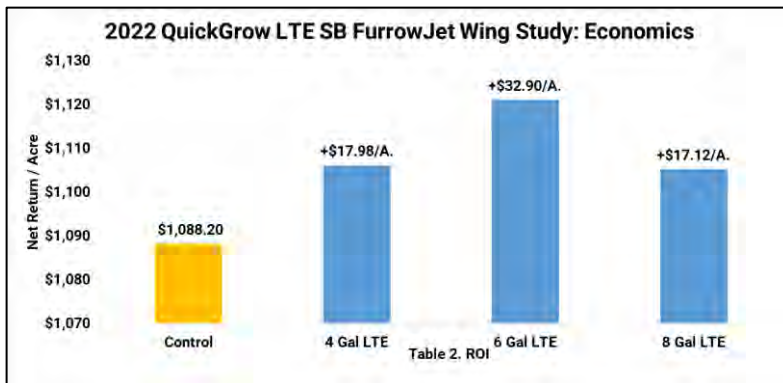

Planting Date: May 16th

Variety: Asgrow® 35XF1

Population: 130K

Row Width: 30"

Rotation: BAC

SB Price: \$13.96

Marco LTE: \$5.10/Gal

Fertilizer Reallocation: \$30/Acre

QLF™ L-CBF 7-21-3 MKP FurrowJet® Study

Objective: To evaluate yield and net return of QLF™ Agronomy’s Liquid Carbon-Based Fertilizer (L-CBF) starter 7-21-3 MKP applied through FurrowJet® Wings (Figure 1).

Figure 1. FurrowJet® Wing Application



L-CBF 7-21-3 is a liquid starter blend derived from premium orthophosphate MKP (monopotassium phosphate) for plant available phosphorus, available carbon from sugar cane molasses as an energy source for soil microbes and enhanced biological function with an added fermentation yeast extract.

Results: L-CBF 7-21-3 treatments resulted in yield gains of +0.6 Bu/A. to +0.9 Bu/A., with the 3 Gal/A. rate providing economic optimum rate with returns at +\$20.98/A.

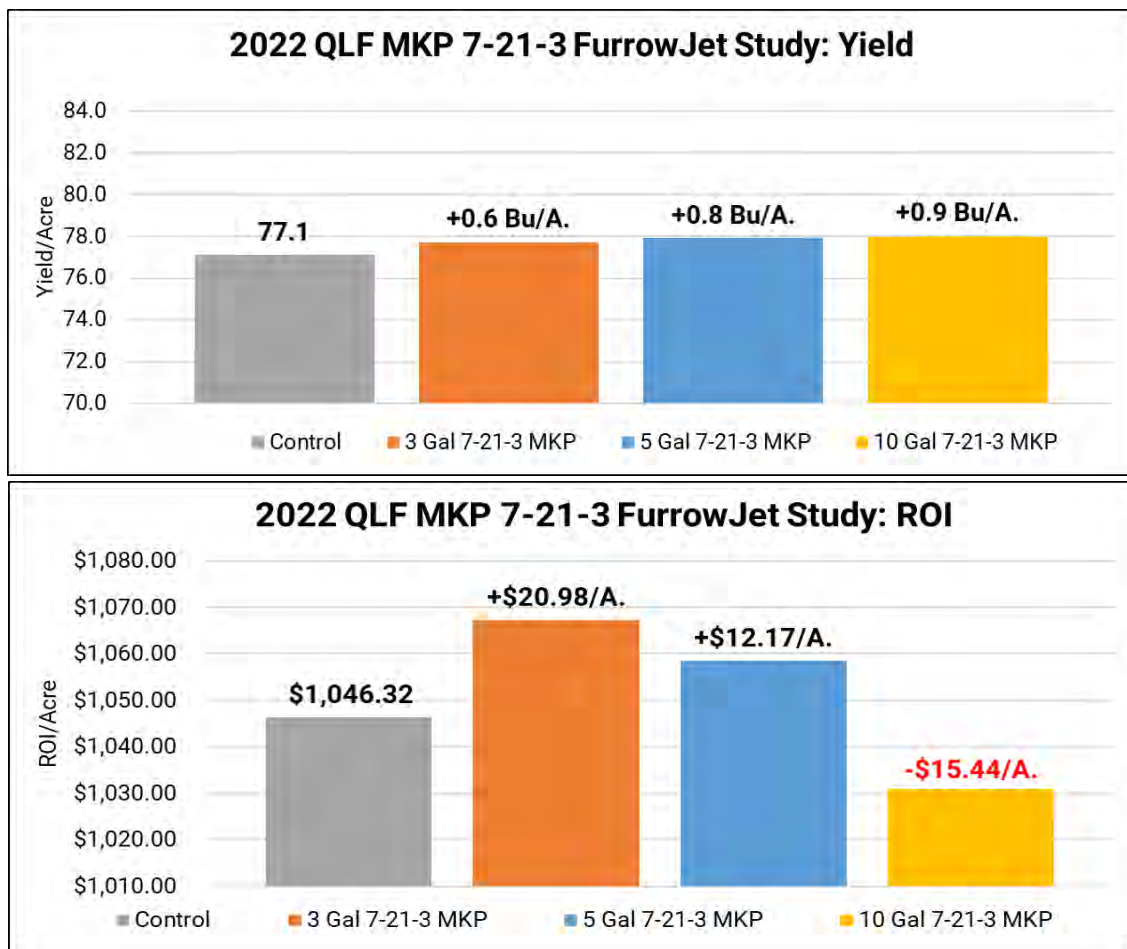

FurrowJet® Side-Wall Study

Objective: FurrowJet® system is a planter fertilizer attachment (Figure 1.) that enables placement of not only an in-furrow starter fertilizer, but also a dual-band of fertilizer 3/4" on each side of the seed. To achieve this dual-band placement, the wings on FurrowJet® system angle downward to cut into the sidewall and place fertilizer alongside the seed in a dual-band. By doing this, lifting and fracturing can occur that potentially could remove soil smearing or compaction created by disc openers. Additionally, closing wheel systems following FurrowJet® wings have a better opportunity to close the seed trench, remove air pockets, and allow for good seed-to-soil contact.

This study evaluates FurrowJet® dual-band wings offering the ability to cut, lift and remove side-wall compaction in the seed furrow (Figure 2). For this study, no liquid fertilizer was applied.

Results: In 2022, FurrowJet® alleviating sidewall density resulted in +0.9 Bu/A. average yield gains. Table 1. below illustrates multi-year data over 2020-2022 with average yield gain of +1.5 Bu/A. Using a soybean commodity price of \$13.96 and a cost of \$320/Row for FurrowJet® systems, break-even would occur on a 16-row planter with this scenario at 245 acres, not even considering any liquid fertilizer potential benefit.

Figure 1. FurrowJet®



Figure 2: FurrowJet® Dual-Band Wings Fracturing Side-Walls



2020-2022 PTI Farm Soybean FurrowJet Sidewall Study: Yield

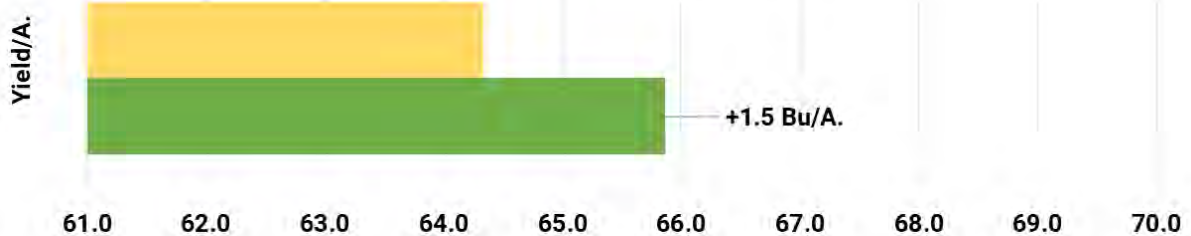

Table 1.

Control	64.3
FurrowJet Cut	65.9

QLF™ L-CBF 5-5-5-1S Study

Objective: To evaluate yield and net return of QLF™ Agronomy’s Liquid Carbon-Based Fertilizer (L-CBF) 5-5-5-1S applied in-furrow, and foliar at the V3 and R3 soybean growth stages.

5-5-5-1S is a carbon based balanced source of foliar nitrogen, phosphorous, potassium and sulfur with available carbon in a low pH chemistry package. L-CBF 5-5-5-1S has 20% sugar, which for every gallon over 2# pounds of sugar is delivered in a microscopic form, raw and undegraded, further enhancing the adjuvant characteristics of this liquid fertilizer blend.

Derived from sugar cane molasses with an added fermentation yeast extract for enhanced biological function. L-CBF 5-5-5-1S is a safer and more efficient approach to foliar applications and plant protein formation.

Results: All 5-5-5-1S treatments proved positive yield gains of +1.6 to +3.0 Bu/A. with net revenue gains of +\$8.72 to +\$13.08/A.

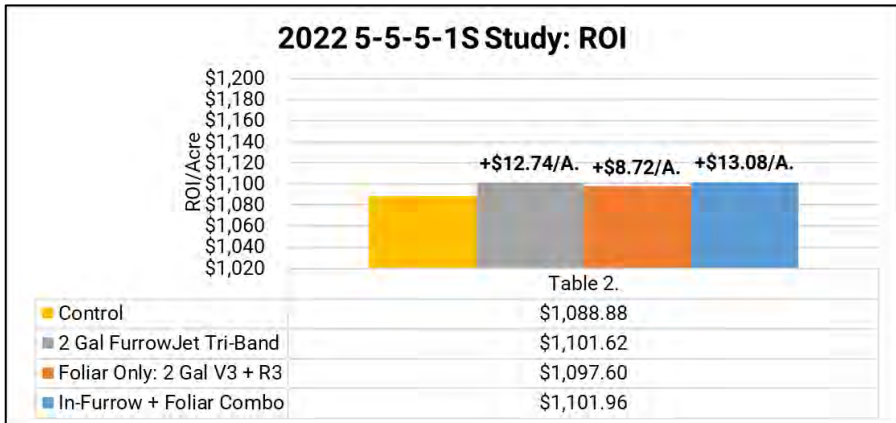
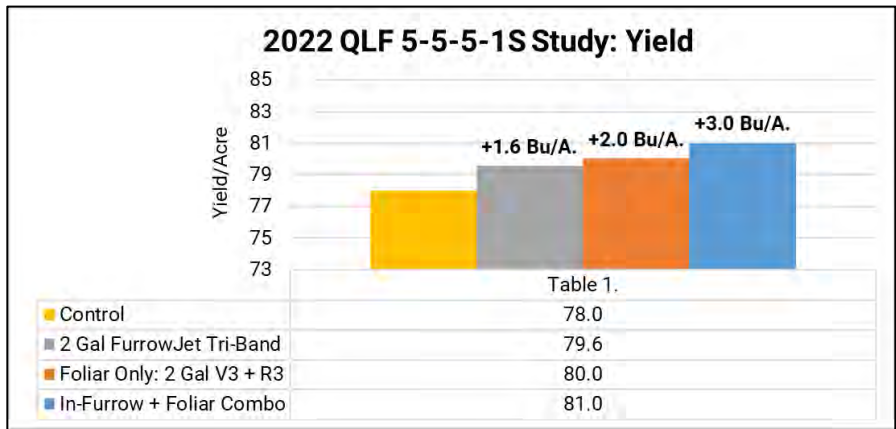

Nachurs® At-Plant Soybean Nutritional Placement Study

Objective: To evaluate the yield and economic impact of an at-plant soybean liquid starter fertilizer program from Nachurs®. This trial focuses on nutritional placement that consists of the following:

Treatments and Placement:

#1. Control:	None
#2 At-Plant Fertility:	
Conceal® Dual Band (Figure 1.)	5 Gal Nachurs Throwback®, 1Qt Nachurs Humi-Flex® Max 3 Gal K-Fuse®, 0.5 Gal Nachurs SideSwipe®
FurrowJet® Center: (Figure 2.)	1Qt Rhyzo-Link® PE, 1 Gal Balance® 1Pt Nachurs HumiFlex® FA, 1Pt Calcium 3%
FurrowJet® Wings: (Figure 2.)	1 Gal Balance®, 2 Gal TripleOption®



Figure 1. Conceal Placement

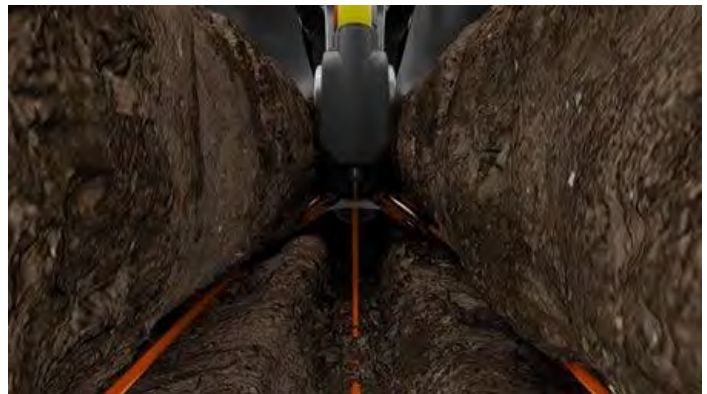
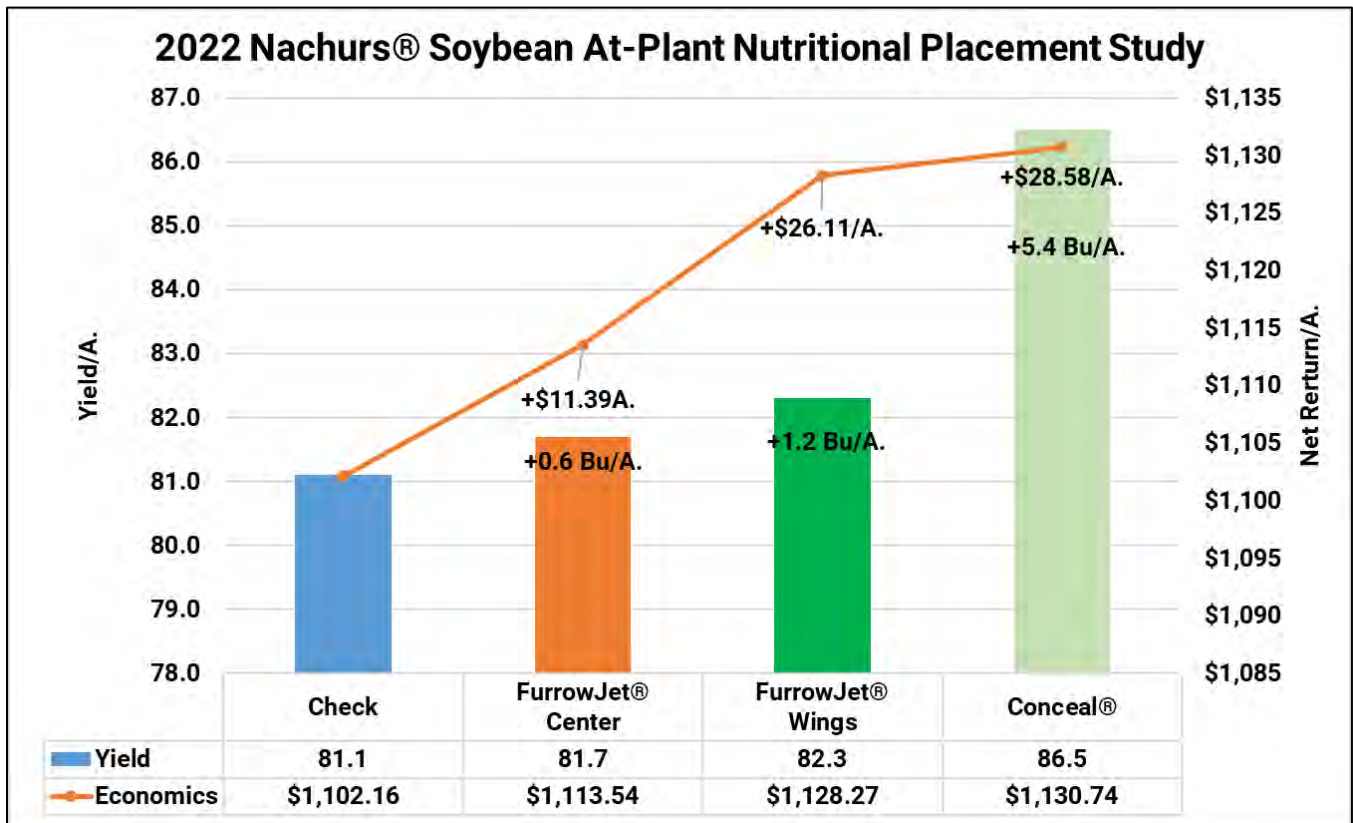

Figure 2. FurrowJet® Placement

Nachurs® At-Plant Soybean Nutritional Placement Study

All treatments (including control) received 13.7oz/A. of Miravis® Neo at R1 and 13.7oz/A. of TrivaPro® at R3 growth stages.

Results: The table below illustrates at-plant FurrowJet® center treatments achieved 81.7 Bu/A., +0.6 Bu/A. and +\$11.39/A. over the control. At-plant + FurrowJet® Wing treatments offered yields of 82.3 Bu/A., +1.2 Bu/A. and +\$26.11/A. gains over the control. Conceal® offered highest yields and highest individual contribution of yield at 86.5 Bu/A., +5.4 Bu/A. and +\$28.58/A. over the control.



Planting Date: May 18th

Variety: Asgrow® 27FX1

Population: 130K

Row Width: 30"

Rotation: BAC

SB Price: \$13.96

FurrowJet® Center: \$26.99/A.

FurrowJet® Wing: \$20.64/A.

Conceal®: \$76.80/A.

Fertilizer Re-Allocation: \$30/A.

The Anderson's® Soybean At-Plant Nutritional Placement Study

Objective: To evaluate the yield and economic impact of an at-plant soybean liquid starter fertilizer program from Nachurs®. This trial focuses on nutritional placement that consists of the following:

Treatments and Placement:

#1. Control:	None
#2 At-Plant Fertility:	
Conceal® Dual Band (Figure 1.)	5 Gal/A. 32% UAN, 15 Gal/A. 14-12-4-6, 2Pt/A. SB Mix 11 64oz/A. Korrekt® Plus, 1 Gal/A. UltraMate™
FurrowJet® Center: (Figure 2.)	1.5 Gal/A. First Pass® with MicroCarb® + 1Pt/A. BioPass™
FurrowJet® Wings: (Figure 2.)	1.5 Gal/A. First Pass® with MicroCarb® + 5 Gal/A. water



Figure 1. Conceal Placement



Figure 2. FurrowJet® Placement

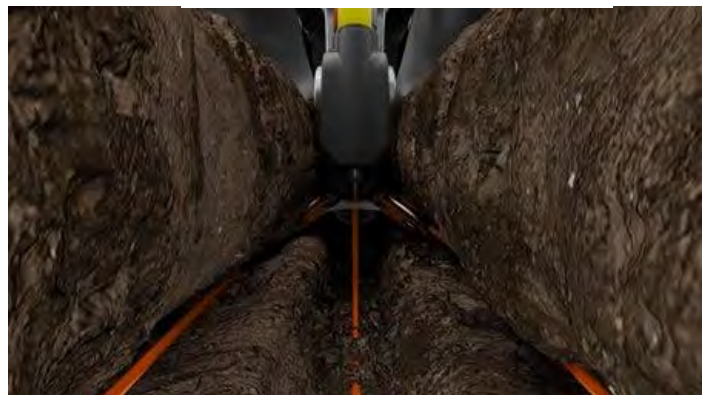

The Anderson's® Soybean At-Plant Nutritional Placement Study

All treatments (including control) received 13.7oz/A. of Miravis® Neo at R1 and 13.7oz/A. of TrivaPro® at R3 growth stages.

Results: The table below illustrates at-plant FurrowJet® center treatments achieved yields of 69.1 Bu/A., +1.3 Bu/A. and +\$25.93/A. over the control.

At-plant + FurrowJet® Wing treatments offered yields of 68.9 Bu/A., +1.1 Bu/A. and +\$33.43/A. gains over the control.

Conceal® offered highest yields and highest individual contribution of yield at 71.1 Bu/A., +3.3 Bu/A. better than the control, however lost **-\$23.33/A.** due to high cost of program.

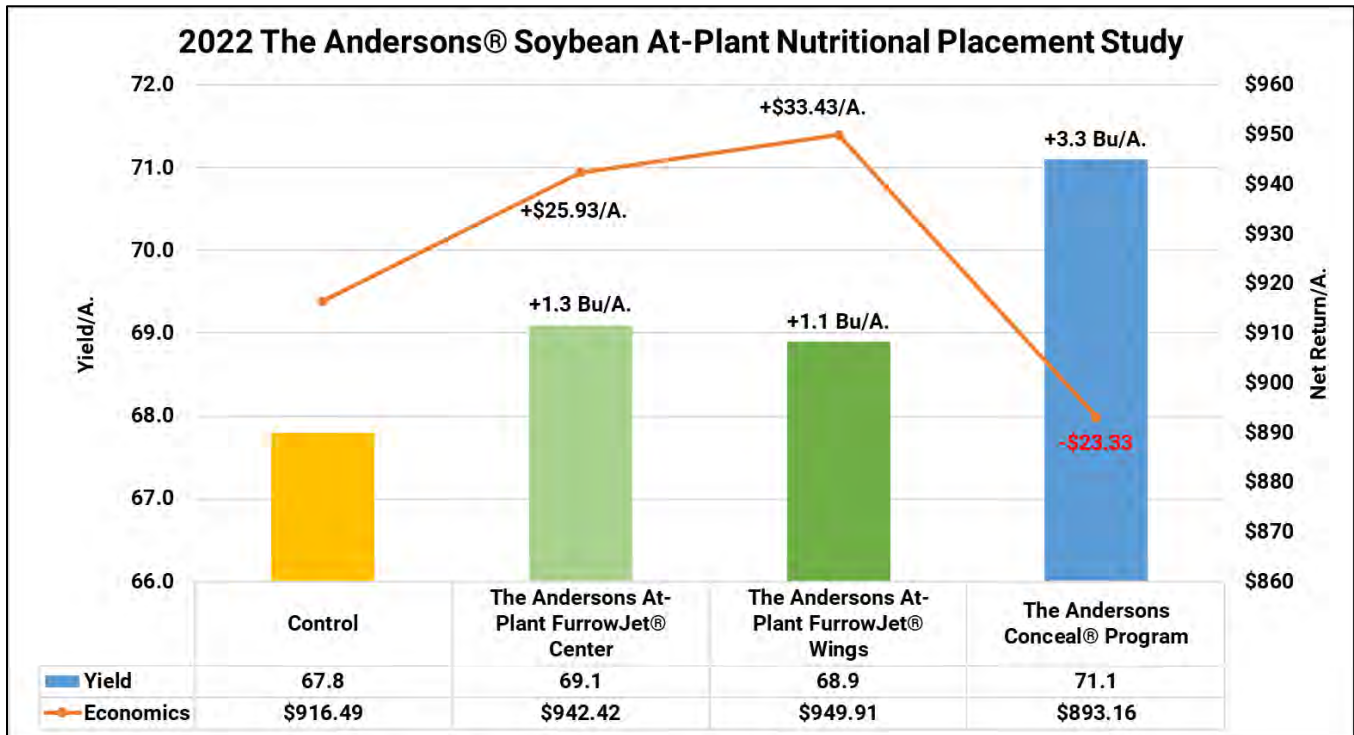

Planting Date: May 5th Variety: Asgrow® 35FX1 Population: 120K Row Width: 30" Rotation: BAC SB Price: \$13.96

FurrowJet® Center: \$22.22/A FurrowJet® Wings: \$11.93/A. Conceal® Program: \$99.40/A. Fert Reallocation: \$30/A.

AgroLiquid® Soybean At-Plant Nutritional Placement Study

Objective: To evaluate the yield and economic impact of a corn liquid starter fertilizer and foliar nutritional program from AgroLiquid in a high management irrigated environment. This trial consisted of the following:

Treatments and Placement:

Control:	None
At-Plant Fertility:	
FurrowJet® Center: (Figure 1.)	1 Gal/A. Sure-K® 1Qt/A. Micro500™ 1 Gal/A. SpringUp® 2 Gal/A. Water
FurrowJet® Wings Only:	1 Gal/A. Sure-K® 1Qt/A. Micro500™ 1 Gal/A. SpringUp® 5 Gal/A. Water



Figure 1. FurrowJet® Placement



AgroLiquid® Soybean At-Plant Nutritional Placement Study

All treatments (including control) received 13.7oz/A. of Miravis® Neo at R1 and 13.7oz/A. of TrivaPro® at R3 growth stages.

Results: The table below illustrates at-plant FurrowJet® center treatments achieved yields of 68.1 Bu/A., +0.8 Bu/A. and +\$21.76/A. over the control.

At-plant + FurrowJet® tri-band treatments offered yields of 69.2 Bu/A., +1.9 Bu/A. and +\$37.11/A. gains over the control.

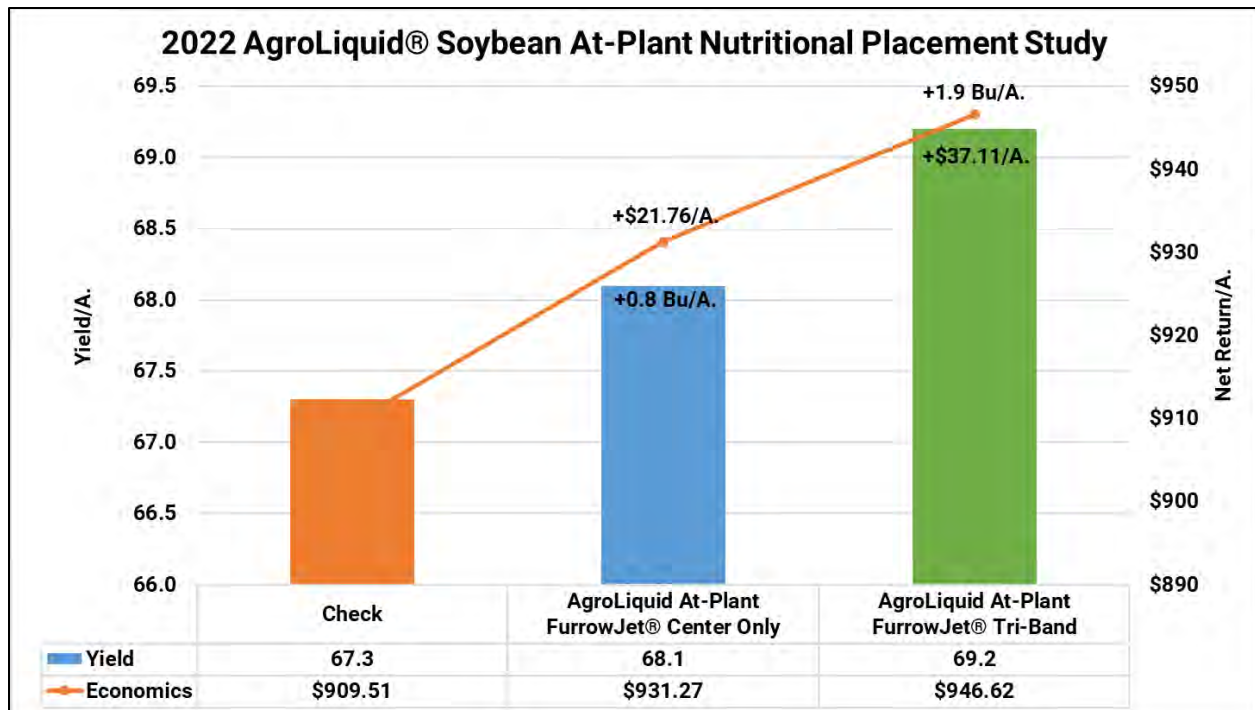

Planting Date: May 5th

Variety: Asgrow® 35XF1

Population: 120K

Row Width: 30"

Rotation: BAC

SB Price: \$13.96

FurrowJet® Program: \$19.41

Fert Reallocation: \$30/A.

Marco Fertilizer NutriStart BOOST 14-12-4-6S Study

Objective: This trial evaluates the yield and net return of Conceal® system dual band treatments of NutriStart™ BOOST 14-12-12-4-6S at 10, 15, and 20 Gal/A. rates. This liquid fertilizer is a 70% polyphosphate and 30% orthophosphate formula designed for non-in furrow applications in soybeans. NutriStart products are manufactured with Marco 10-34-0, Potassium - soluble potash (K2O), Sulfur - Ammonium Thiosulfate and Zinc - 9% EDTA.



Conceal® system is an ideal placement for this product as its far enough away from the seed furrow to prevent seed injury, yet close enough to enable access to seedling nutrition (Figure 1).

Results: Table 1. illustrates that all rates of 14-12-4-6S proved positive yield gains from +1.3 to +5.0 Bu/A., however 15 Gal/A. provided the economic optimum rate resulting in a positive return on investment of +\$63.05/A.

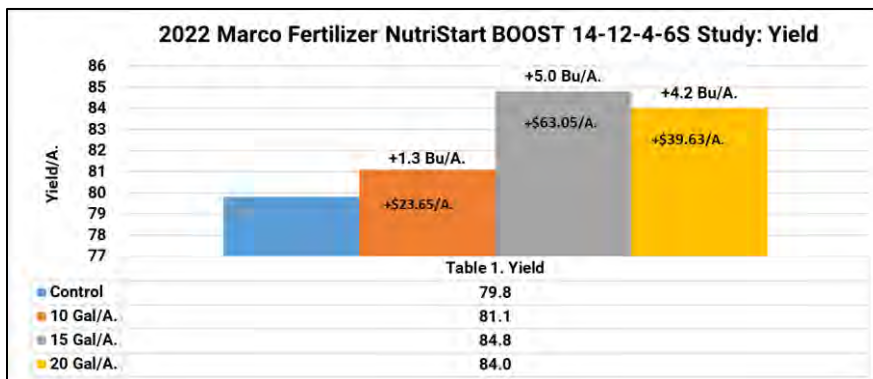

Table 2. reveals long-term multi-year economics during 2018-2022. Over this 4-year period, economic optimum has occurred at the 15 Gal/A. rate of NutriStart BOOST with an average return on investment of +\$47.21/A. NutriStart BOOST has been a solid performer at the PTI farm achieving some of the highest yield and economic gains in soybeans.

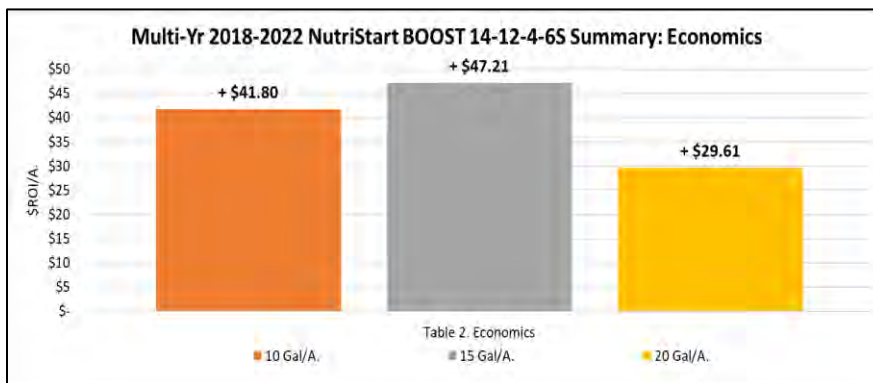

Figure 1. Conceal Dual Placement



K-Fuse® Potassium Study

Objective: To evaluate the yield and economics of Nachurs® K-Fuse® powered by Bio-K® (Figure 1.), a 6-0-12-12S potassium/sulfur product designed to be applied on the planter or at side-dress. For this study we applied one, three, and five gallons of K-Fuse® at planting in a dual band Conceal® system application (Figure 2).

Results: Tables 1-2. illustrate dual band K-Fuse® Conceal® system applications proved yield increases of +1.7 to +2.9 Bu/A. with the 3 Gal/A. rate economic optimum rate/A. with returns at +\$20.68/A.

Table 3. shows multi-year economic response from 2019 to 2022 crop years, 3 Gal/A. providing the economic optimum rate. Over this time frame.

Figure 1. Nachurs K-Fuse® Potassium Additive

NACHURS®

NUTRIENTS SUPPLIED (pounds per gallon):
 Total Nitrogen (N) 0.65
 Soluble Potash (K₂O) 1.30
 Sulfur (S)..... 1.30

Derived from: Potassium Acetate, Ammonium Thiosulfate, and Urea.

PRODUCT PROPERTIES:
Analysis:..... 6-0-12-12S
Weight:..... 10.8 lbs. per gallon
Specific gravity:..... 1.30 kg/L
pH: 7.4–7.9
Appearance:..... Clear, nearly colorless
Odor:..... Ammonia odor

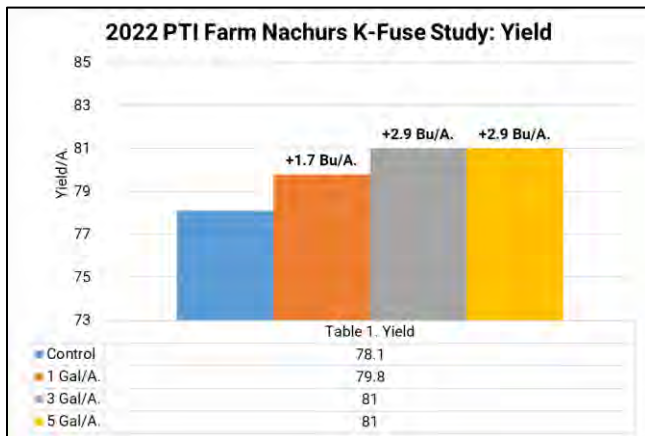
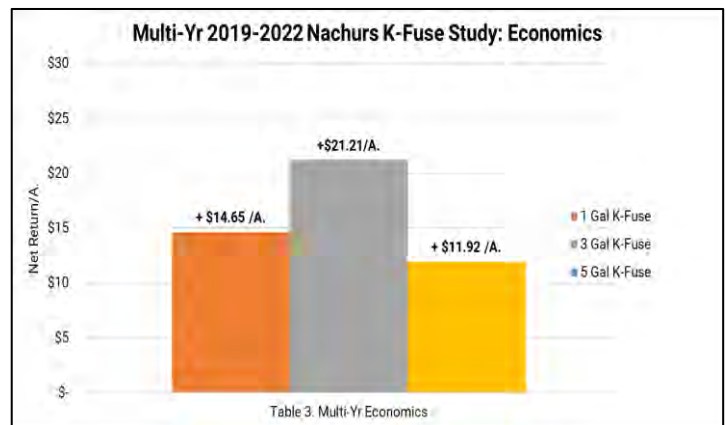
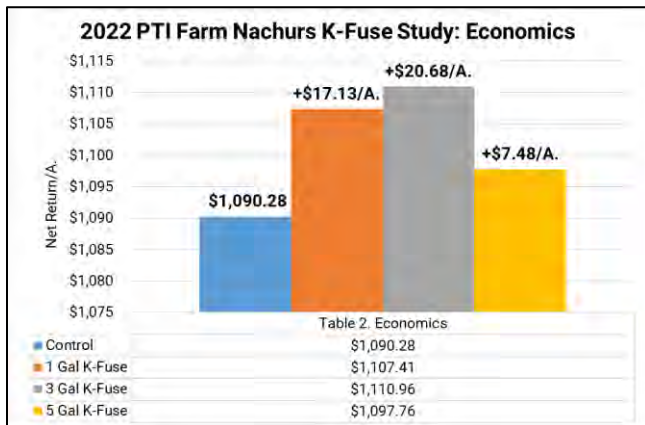
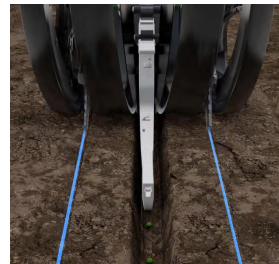

Figure 2. Conceal Dual Placement 3" from Seed Furrow, 1.5" in Depth



Soybean Summary of 2022 FurrowJet® Applications

Study	Classification	Yield (Bu/A.)	\$ROI	Page #
AgroLiquid SB High Management Nutritional Study Conceal & FJ	Starter Fertilizer	3.9	\$ 65.03	207-208
Stoller SB High Management Nutritional Study FJ	PGR, Starter Fertilizer	3.7	\$ 62.11	213-214
Nachurs SB High Management Nutritional Study Conceal & FJ	Starter Fertilizer	9.5	\$ 47.64	205-206
AgroLiquid SB At Plant Nutritional Program: FJ 3-Way	Starter Fertilizer	1.9	\$ 37.11	230-231
Stoller USA SB FJ: Combo	PGR, Starter Fertilizer	4.1	\$ 34.44	220-221
Anderson's SB At Plant Nutritional Program: FJ Wings	Starter Fertilizer	1.1	\$ 33.43	228-229
Marco QuickGrow LTE: 6Gal	Starter Fertilizer	2.4	\$ 32.90	222
Nachurs SB At Plant Nutritional Program: FJ Wings	Starter Fertilizer	1.2	\$ 26.11	226-227
Anderson's SB At Plant Nutritional Program: FJ Center	Starter Fertilizer	1.3	\$ 25.93	228-229
AgroLiquid SB At Plant Nutritional Program: FJ Center	Starter Fertilizer	0.8	\$ 21.76	230-231
QLF 7-21-3: 3 Gal	Starter Fertilizer	0.6	\$ 20.98	223
Anderson's SB High Management Nutritional Study Conceal & FJ	Starter Fertilizer	8.9	\$ 20.69	209-210
Marco QuickGrow LTE: 4Gal	Starter Fertilizer	0.6	\$ 17.98	222
Marco QuickGrow LTE: 8Gal	Starter Fertilizer	2	\$ 17.12	222
Stoller USA SB FJ: Center	PGR, Starter Fertilizer	1.3	\$ 13.90	220-221
QLF 5-5-5-1S FJ	Starter Fertilizer	1.6	\$ 12.74	225
FurrowJet Side Wall Cut	Mechanical	0.9	\$ 12.56	224
QLF 7-21-3: 5 Gal	Starter Fertilizer	0.8	\$ 12.17	223
TerraMax Liquid IF	Innoculant	1.1	\$ 11.58	191
Nachurs SB At Plant Nutritional Program: FJ Center	Starter Fertilizer	0.6	\$ 11.39	226-227
Marco SB High Management Nutritional Study Conceal & FJ	Starter Fertilizer	5.4	\$ 7.58	211-212
Stoller USA SB FJ: Wings	PGR, Starter Fertilizer	0.8	\$ (7.38)	220-221
QLF 7-21-3: 10 Gal	Starter Fertilizer	0.9	\$ (15.44)	223
April 26th Soybean Planting Date with Starter	Starter Fertilizer	2.2	\$ (20.29)	167-168
March 17th Soybean Planting Date with Starter	Starter Fertilizer	1.3	\$ (32.85)	167-168
May 18th Soybean Planting Date with Starter	Starter Fertilizer	0.7	\$ (41.23)	167-168
Average		2.29	\$ 16.46	



Soybean Summary of 2022 Conceal® Applications

Study	Classification	Yield (Bu/A.)	\$ROI	Page #
Marco 14-12-4-6S: 15Gal	Starter Fertilizer	5	\$ 63.05	232
Nachurs SB High Management Nutritional Study Conceal & FJ	Starter Fertilizer	9.5	\$ 47.64	205-206
Brandt High Management SB Conceal	Starter Fertilizer	5.4	\$ 40.73	215-216
Marco 14-12-4-6S: 20Gal	Starter Fertilizer	4.2	\$ 39.63	232
Nachurs SB At Plant Nutritional Program: Conceal	Starter Fertilizer	5.4	\$ 28.58	226-227
Marco 14-12-4-6S: 10Gal	Starter Fertilizer	1.3	\$ 23.65	232
Anderson's SB High Management Nutritional Study Conceal & FJ	Starter Fertilizer	8.9	\$ 20.69	209-210
Nachurs K-Fuse SB: 3 Gal	Starter Fertilizer	2.9	\$ 20.68	233
Nachurs K-Fuse SB: 1 Gal	Starter Fertilizer	1.7	\$ 17.13	233
Marco SB High Management Nutritional Study Conceal & FJ	Starter Fertilizer	5.4	\$ 7.58	211-212
Nachurs K-Fuse SB: 5 Gal	Starter Fertilizer	2.9	\$ 7.48	233
April 26th Soybean Planting Date with Starter	Starter Fertilizer	2.2	\$ (20.29)	167-168
Anderson's At Plant Nutritional Program: Conceal	Starter Fertilizer	3.3	\$ (23.33)	228-229
March 17th Soybean Planting Date with Starter	Starter Fertilizer	1.3	\$ (32.85)	167-168
May 18th Soybean Planting Date with Starter	Starter Fertilizer	0.7	\$ (41.23)	167-168
Average		4.01	\$ 13.28	

Soybean Rolling Study

Objective: To study the yield and economic impact of rolling soybeans. A Brandt® roller (Figure 1.) was used in replicated strips at the growth stage V3.

The benefits of using a roller in soybeans include the following:

- Pushing or pressing rocks into soil to avoid harvest issues
- Lays corn residue flat to aid in cleaner seed at harvest
- Stimulate reproductive growth after rolling damage occurs



Figure 1. Brandt® Roller



Soybean Rolling Study

Results:

It was very interesting evaluating soybean plants that were rolled in this year's study. Figure 2 is an example of the difference between rolled soybeans at harvest. One clear goal in rolling soybeans was to shorten internodes and to hopefully create more nodes, pods, and beans.

Rolled soybean plants exhibited average internode length of 1.98", while non-rolled soybean at 2.3" in length. It is very clear to see the difference in both internodal length and total number of pods in the Figure 2. photo. Total nodes in rolled soybeans equaled 23, while non-rolled only 19.

Total seed count in rolled soybean planted tallied 214 beans/plant or 9.3 beans/node, while non-rolled at 151 beans/plant or 7.9 beans/node.

However, rolling did lower stand counts, due to soybean plants that simply broke off at the main stem and ultimately caused plant death. On average, plant stand was reduced by 10%. 130K plant stands were reduced to 117,000 plants/acre.

Figure 2. Rolled vs Non-Rolled Soybeans at Harvest



Soybean Rolling Study

Results: Table 1. illustrates soybeans rolled at the V3 growth stage resulted in yield gains of +3.6 Bu/A. and positive economic gains of +\$42.26/A. Being our 2nd year rolling soybeans at the PTI Farm, it is important to evaluate multi-year data. Table 2. reviews 2021 rolled soybeans, where +\$28.75/A. net positive returns were realized at V2 growth stage, however as rolling entered V4 growth stage, net losses occurred at -\$16.77/A. We look forward to our 3rd of testing Brandt® rollers in soybeans in 2023.

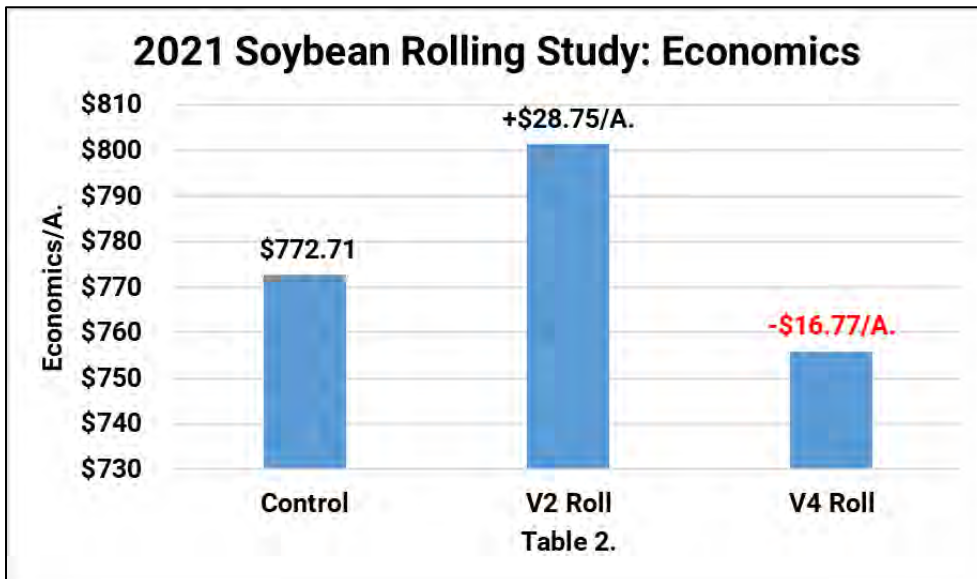
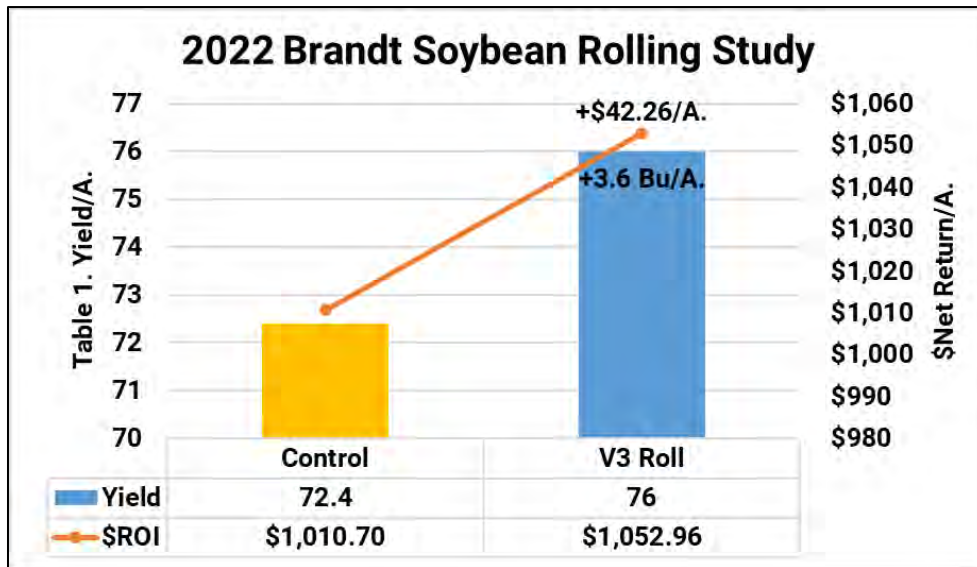

Soybean Strip Planting Study

Objective: This study evaluates the yield and economic advantages of planting corn and soybeans in alternate 40' and 20' strips. The PTI team first evaluated this system in 2020 to harvest more sunlight on outside rows with the intention of trying to stimulate higher corn yield. It is quite common to have higher corn yield on the outside field edges, due to corn being able to harvest more sunlight. However, most often after the first few rows this yield advantage decreases due to more shading of corn biomass.

However, to increase corn yield with this strip cropping system, it seems as if soybeans are used as a “sacrificial lamb” to help

introduce a sunlight corridor to help increase corn yield. As a result, corn rows end up competing and shading soybean rows at various times of the morning and evening hours (Figure 2.). This study is intended to measure the associated economics from this system.

In order to understand the agronomics of this strip cropping system, we split our trial design into four segments:

- 40' Soybean Blocks (16 rows) planted in North/South rows
- 40' Soybean Blocks (16 rows) planted in East/West rows
- 20' Soybean Blocks (8 rows) planted in North/South rows
- 20' Soybean Blocks (8 rows) planted in East/West rows

Figure 1. 40' Alternate Strips of Corn and Soybeans



Soybean Strip Planting Study Continued

Figure 3. 40' (16row) Alternate Strip Planting of Soybeans

Figure 3 illustrates the soybean strips in a 40' or 16 row 30" block formation. These soybean blocks were planted alternatively with 30" corn in both a North to South and East to West planting row to allow the ability to study the differences in sunlight shading. In corn, we also implemented the use of "shorter" stature corn being planted on the outside 4 rows of each 40' or 16 row block in an attempt to minimize shading of the soybeans from the corn.



Figure 4 illustrates soybean strip planting in a 20' or 8 row 30" block formation. These soybeans were also planted alternatively with 30" corn in both a North to South, as well as an East to West planted row to allow the ability to study the differences in sunlight shading and overall yield differences between wide and narrower soybean blocks. Both "shorter" stature corn and a tall hybrid were implemented in the 20' blocks, but only independently and not within the same block.

Figure 4. 20' (8row) Alternate Strips of Soybeans



Soybean Strip Planting Study Continued

In order to understand the agronomics of the 40' or 16 row blocks, we split our 16-row planter into three individual segments to evaluate soybean yield performance:



These three individual segments were then planted in both North to South and East to West directional planting formations to evaluate the yield and economics on planter row direction.

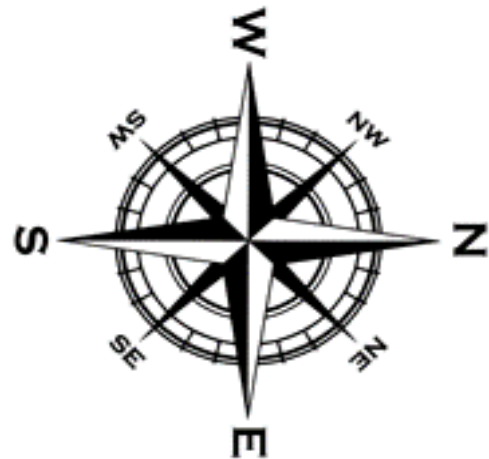
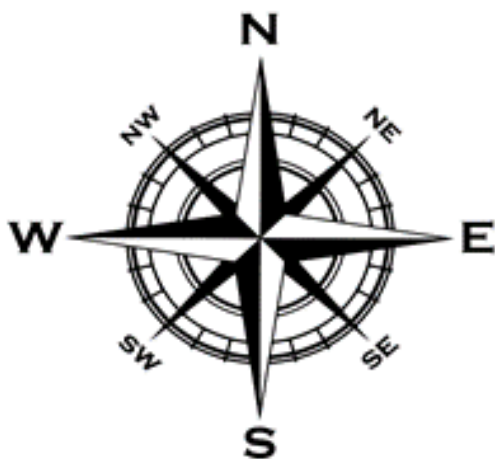

Soybean Strip Planting Study Continued

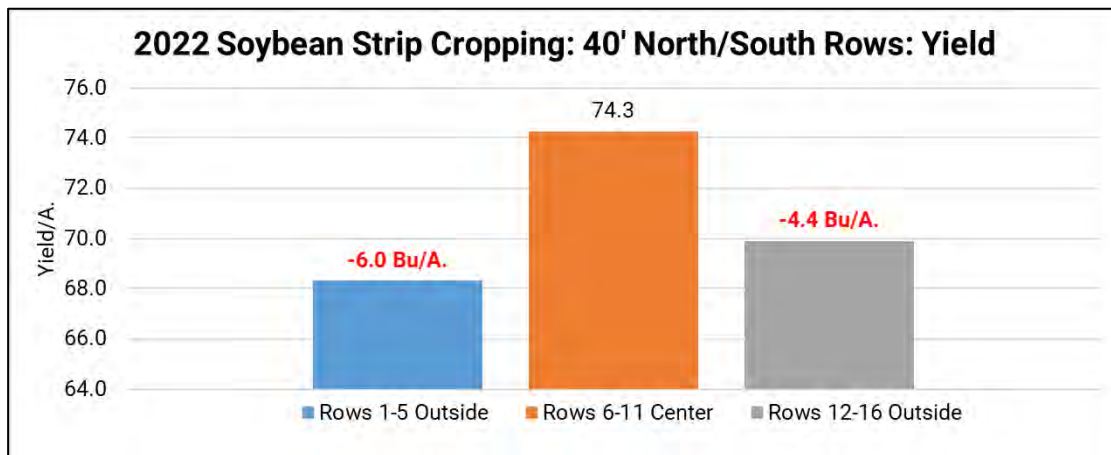

The above graph illustrates the yield response of each planter row segment in the 40' alternate strips planted in a North/South formation. Compared to the center six planter rows, the outside five rows of the planter rows 1-5 and 12-16 offered average yield losses of **-4.4 Bu/A. to -6.0 Bu/A.** Status quo full field planting would equate to 74.3 Bu/A. soybean yield (center 6 rows), while this crop stripping experiment decreased soybean yield to 68.3 Bu/A. and 69.9 Bu/A. on the inside "solar corridor" rows next to the corn.

Overall, north/south row strips planted in 40' (16 row) blocks offered **average** yield losses of **-5.2 Bu/A.** resulting in revenue losses of **-\$72.59/A.**

Soybean Strip Planting Study Continued

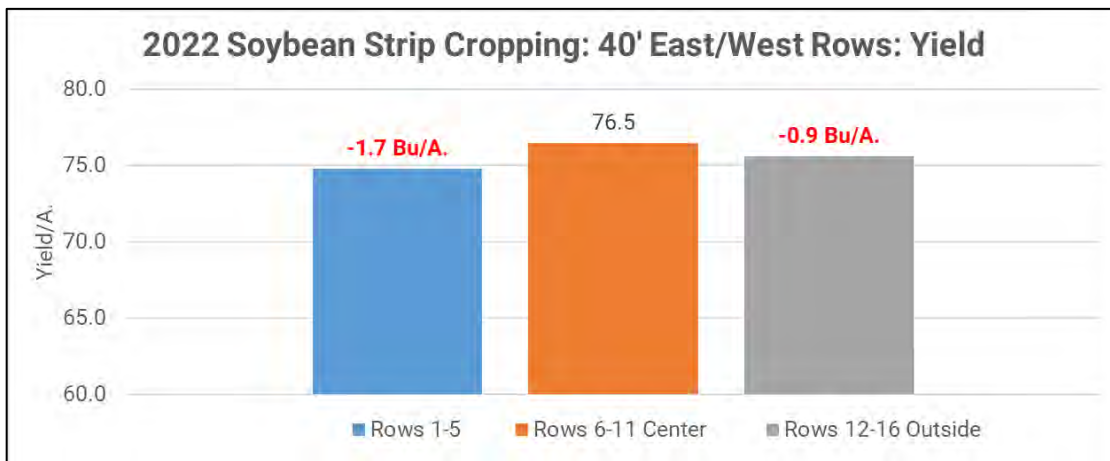

The above graph illustrates the yield response of each planter row segment in the 40' alternate strips planted in an East/West formation. Compared to the center six planter rows, the outside five rows of the planter (rows 1-5 and 12-16) offered average yield losses of **-0.9 Bu/A. to -1.7 Bu/A.** Status quo full field planting would equate to 76.5 Bu/A. soybean yield (center 6 rows), while this crop stripping experiment decreased soybean yield to 74.8 Bu/A. to 75.6 Bu/A. on the inside "solar corridor" rows next to the corn.

Overall, east/west row strips planted in 40' (16 row) blocks offered **average** yield losses of **-1.3 Bu/A.** resulting in revenue losses of **-\$18.15/A.,** a +\$54.38 improvement compared to north/south rows. This more than likely being the difference in less overall sunlight shading in an east/west planting formation compared to north/south.

Soybean Strip Planting Study Continued

To understand soybean yield in strips by block size, 20' (8 row) blocks were planted with a four-row planter. This smaller configuration allows for more "solar corridor" outside rows and reduces the 40' blocks to half the size. Due to the small size of the 20' strips, yield data was only harvested as a single strip.

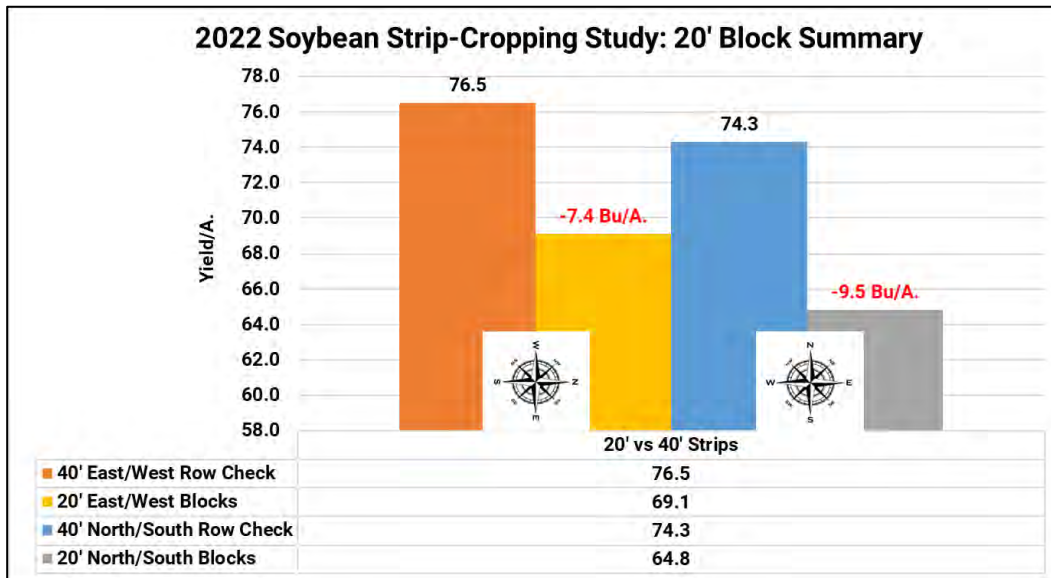

20' soybean blocks offered some of the highest yield losses in this study. 20' blocks planted north/south offered yield losses of **-9.5 Bu/A.** and economic loss of **-\$132.62/A.** compared to 40' centers in the same direction. 20' blocks planted in an east/west formation lightened the loss, but still lost **-7.4 Bu/A.** and revenue of **-\$103.30/A.**

Strip Crop Planting Summary

Objective: This summary evaluates the overall economic advantages of planting corn and soybeans as a system approach in alternate 40' and 20' strips. Individual results by crop are available on pages 142-149 and 238-244.



The graph below illustrates multi-year data from 2021-2022 on the overall economic gains and losses from the strip cropping system at the PTI Farm. Strip cropping corn clearly resulted in impressive yield gains in outside sunlight corridor rows.

However, soybeans are a true sacrificial lamb in this cropping system. Soybeans in a strip cropping system incurred net yield and revenue loss in every block size and planting direction. Net revenue losses were realized from **-\$21.65/A.** to **-\$107.64/A.** with the smaller 20' blocks resulting in the highest soybean losses compared to wider 40' strips. For a strip-cropping system to work effectively with soybeans, an east/west planting formation needs to be implemented to eliminate shading from corn.

Even though soybeans resulted in large yield and revenue losses, it wasn't enough to negate the gains from corn. Yes, soybeans lost money, however it set the stage and allowed corn to flourish in strips. As a result, the overall strip cropping system has resulted in net revenue gains of **+\$121.25** to **+\$202.50/A.** Strip-cropping in 20' blocks planted in east/west rows have dominated over the past two years and have offered the highest over economic return at **+\$202.50/A.**

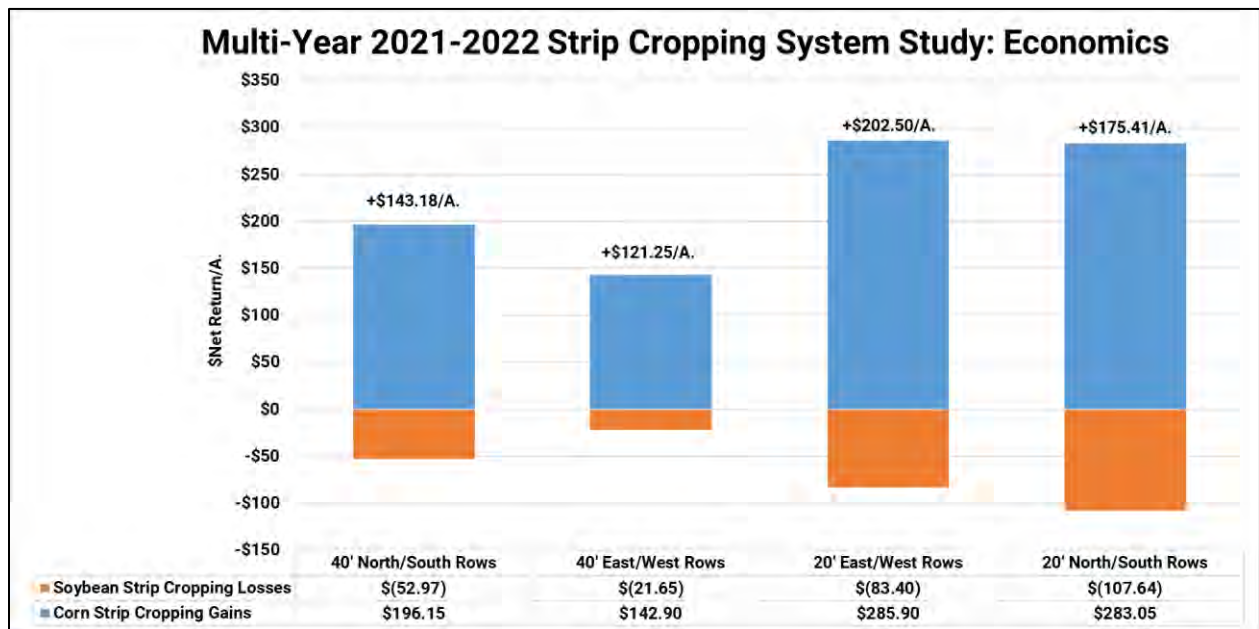

Revytek™ Soybean Foliar Fungicide Study

Objective: To evaluate the yield and net return of a new triazole soybean fungicide introduced in 2020 called Revytek™. Revytek contains Revysol, which is a DeMethylation Inhibitor (DMI) fungicide that is part of the triazole group of fungicides. It was initially labeled for 17 crops, including corn and soybeans. Revytek gives excellent control of frogeye leaf spot, septoria, target spot, and Asian soybean rust.

Mefentrifluconazole	Group	3	Fungicide
Fluxapyroxad	Group	7	Fungicide
Pyraclostrobin	Group	11	Fungicide

Results: Tables 1 illustrates foliar applications of Revytek™ resulted in yield gains of +2.4 Bu/A. at R1 and +4.9 Bu/A. at R3 growth stage applications. Combo R1/R3 resulted in +6.2 Bu/A. yield response.

After cost of application and fungicide, Revytek proved positive net returns of +\$3.81, +\$38.40, and +\$26.55 respectively (Table 2).



Revytek™

Fungicide

BASF
We create chemistry

Active Ingredients*:

mefentrifluconazole: 2-[4-(4-chlorophenoxy)-2-(trifluoromethyl)phenyl]-1-(1H-1,2,4-triazole-1-yl)propan-2-ol	11.61%
pyraclostrobin: (carbamic acid, [2-[[[1-(4-chlorophenyl)-1H-pyrazol-3-yl]oxy]methyl]phenyl]methoxy-, methyl ester)	15.49%
fluxapyroxad: 1H-Pyrazole-4-carboxamide, 3-(difluoromethyl)-1-methyl-N-(3',4',5'-trifluoro[1,1'-biphenyl]-2-yl)-	7.74%
Other Ingredients:	65.16%
Total:	100.00%

*Revytek™ fungicide contains 1.11 lbs mefentrifluconazole, 1.48 lbs pyraclostrobin, and 0.74 lb fluxapyroxad per gallon.

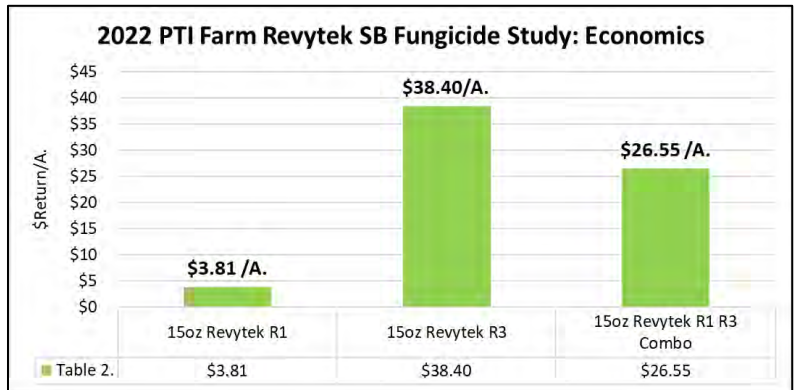
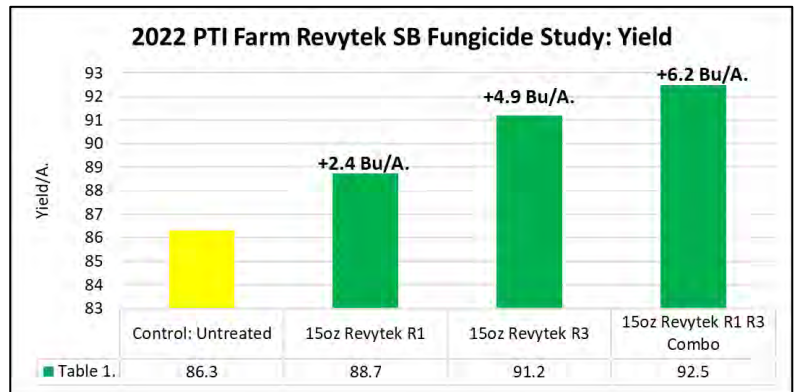

Miravis® Neo™ Soybean Foliar Fungicide Study



Objective: To evaluate the yield and economics of a Miravis® Neo™ application in soybeans.



ADEPIDYN® Technology*

Active Ingredients:

Pydiflumetofen**	7.0%
Azoxystrobin***	9.3%
Propiconazole****	11.6%

Other Ingredients: 72.1%

Total: 100.0%

Miravis® Neo fungicide combines propiconazole, azoxystrobin and Adepidyn technology – one of the most powerful, broad spectrum SDHI molecules available, and delivers superior plant-health benefits and improved preventive and curative control of key such as Brown Spot, Pod and Stem Blight, Frogeye Leaf Spot, Anthracnose, Powdery Mildew and White Mold (suppression).



PYDIFLUMETOFEN	GROUP	7	FUNGICIDE
PROPICONAZOLE	GROUP	3	FUNGICIDE
AZOXYSTROBIN	GROUP	11	FUNGICIDE

Results: Early R1 applications of Miravis®Neo resulted in only +1.2 Bu/A. yield responses with economic losses at **-\$12.43/A.**

R3 individual treatments resulted in nice yield gains at +4.2 Bu/A. with positive economic gains of +\$29.45/A.

R1 + R3 sequential treatments achieved highest yield response at +4.4 Bu/A., however just broke even with returns of +\$3.06/A.

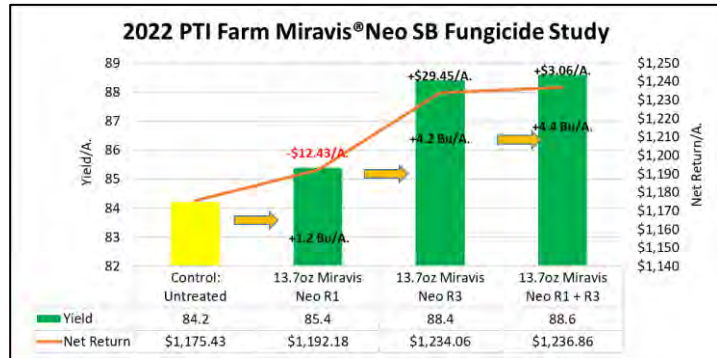

AgroLiquid® Kapitilize® Foliar Soybean Study

Objective: To evaluate the yield and economic impact of AgroLiquid’s Kapitilize®, a foliar 3-1-8 potassium product that also contains calcium and sulfur.

As a primary plant nutrient, potassium is a vital component in a variety of plant processes, including seed development.

Calcium is also important for the proper plant development and high yields. Kapitilize® is a fast-acting potassium fertilizer formulated to provide critical nutrition to crops through these reproductive stages.

Results: Combination R1+R3 Kapitilize® treatments offered highest agronomic and economic response with yield gains of +3.6 Bu/A. and positive net returns of +\$27.13/A. Single applications at R1 and R3 resulted in similar gains of each other at +1.8 and +2.0 Bu/A. with corresponding net returns of +\$13.56 to +\$16.36/A.



Kapitalize 3-1-8
with 0.5% Calcium and 1% Sulfur

Guaranteed Analysis

Total Nitrogen (N) -----	3.00%
0.7% Ammoniacal Nitrogen	
2.3% Nitrate Nitrogen	
Available Phosphate (P ₂ O ₅) -----	1.00%
Soluble Potash (K ₂ O) -----	8.00%
Calcium (Ca) -----	0.50%
Sulfur (S) -----	1.00%
6% Combined Sulfur (S)	

Derived from: Ammonium Nitrate, Potassium Carbonate, Potassium Polyphosphate, Potassium Sulfate, Calcium Sulfate

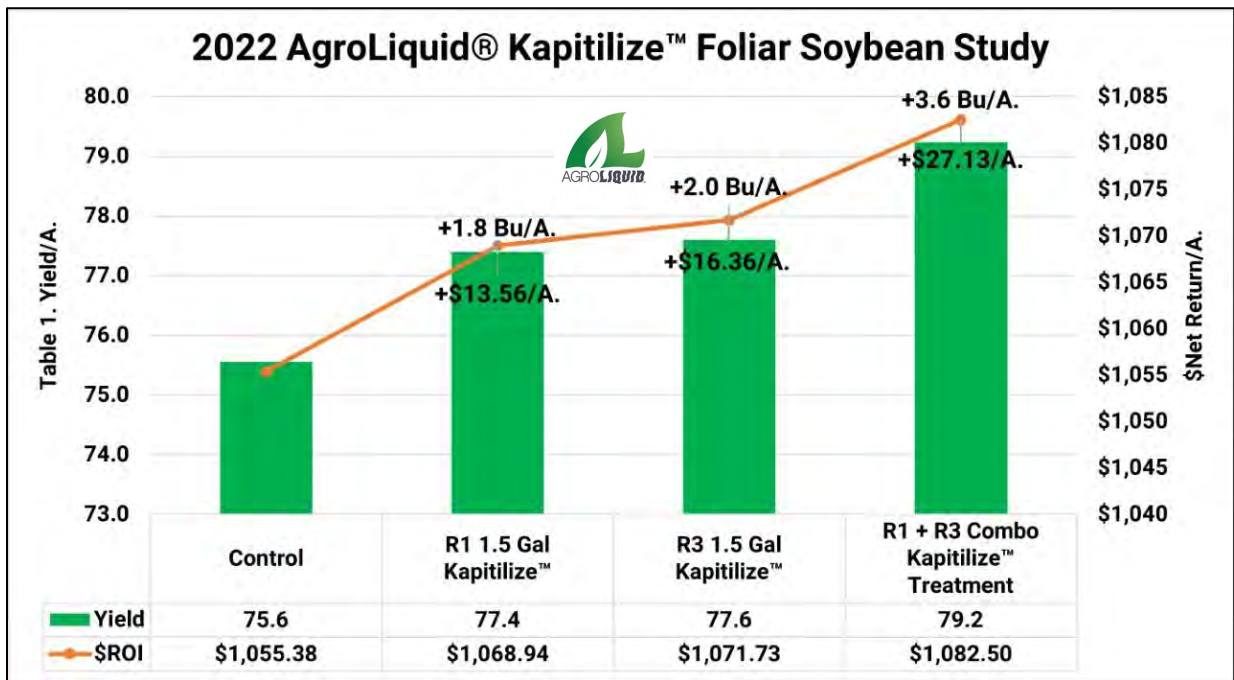

Planting Date: May 15th Variety: Asgrow® 35FX1 Population: 130K Row Width: 30" Rotation: BAC SB Price: \$13.96 Kapitilize®: \$7.71/Gal.

QLF™ L-CBF Amino 15™ Foliar Study

Objective: To evaluate yield and net return of QLF™ Agronomy’s Liquid Carbon-Based Fertilizer (L-CBF) Amino 15-0-1 applied foliar at the R3 soybean growth stage.

Amino 15-0-1 is a balanced source of foliar nitrogen with available carbon in a low pH chemistry package. L-CBF Amino 15-0-1 has 10% sugar. For every gallon, a full pound of sugar is delivered in a microscopic form, raw and undegraded, further enhancing the adjuvant characteristics of this liquid fertilizer blend.

Derived from sugar cane molasses with an added fermentation yeast extract for enhanced biological function, and paired with high quality Urea solution and L-Amino Acid forms of nitrogen, L-CBF Amino 15-0-1 is a safer and more efficient approach to foliar nitrogen applications and plant protein formation.

Results: Amino-15 proved yield gains of +0.8 to +1.6 Bu/A., however failed to reach positive economic gain at each application rate.

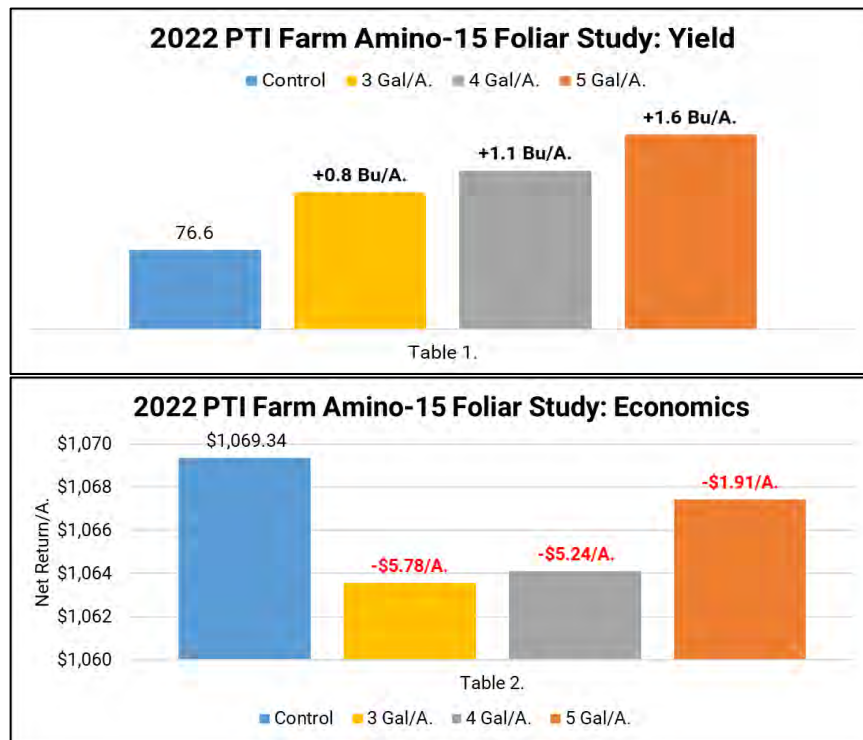

Soybean Tillage Study

Objective: To evaluate the yield and economic impacts of various tillage programs in a soybean after corn rotation. Tillage programs include strip-till, vertical till, and no-till.

Table 1. University of IL Machinery Cost Estimates

Tillage Practice	Category	Cost
Conventional Till	Ripper	\$ 27.70
	Soil Finisher	\$ 13.60
	Plant	\$ 17.20
	Total:	\$ 58.50
Strip Till	Strip	\$ 17.30
	Burndown	\$ 8.00
	Plant	\$ 17.20
	Total:	\$ 42.50
Vertical Till	Vertical	\$ 13.20
	Burndown	\$ 8.00
	Plant	\$ 17.20
	Total:	\$ 38.40
No Till	Burndown	\$ 8.00
	Plant	\$ 19.00
	Total:	\$ 27.00

Figure 1. Sunflower® 6833 Vertical Tillage Tool



Figure 2. Planting in No-Till



Figure 4. Kuhn® Krause® Gladiator®



Figure 3. Sunflower® 4630 Disc Ripper



Soybean Tillage Study Continued

Results: To understand both yield and economics, the University of Illinois Machinery Cost Estimate Summary is used to calculate individual cost of each tillage program (Table 1). For the three reduced tillage programs, an extra \$8/A. burn-down is also included due to higher herbicide costs in 2022.

Table 2. illustrates the overall yield for each tillage segment. The yields varied less than 1.0 Bu/A. between all tillage programs with conventional tillage offering the highest yield of 86.6 Bu/A.

After applying all appropriate costs to each individual tillage segment, no-till offered the highest overall revenue in this tillage system study in 2022. Compared to no-till, strip-till offered losses of **-\$12.71/A.**, vertical tillage **-\$7.21/A.** and due to higher equipment cost, conventional tillage with the highest losses of **-\$13.73/A.** (Table 3.)

Table 4. illustrates multi-year data from the PTI Farm over the time period of 2018-2022. Over this time frame, no-till has provided economic gains of **+\$1.67/A.** over strip-till, **+\$8.78/A.** over conventional till and **+\$10.26/A.** over vertical tillage.

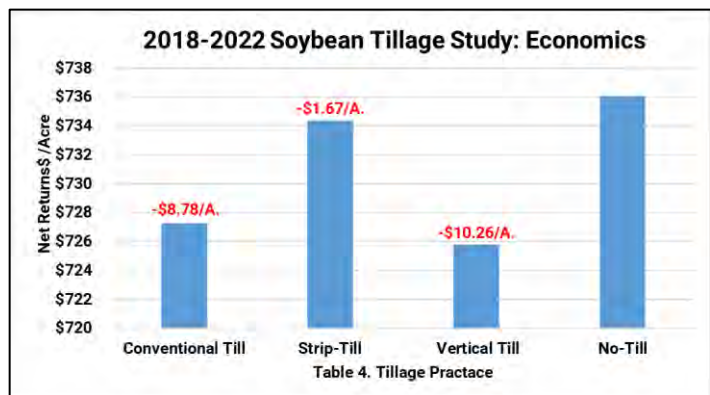
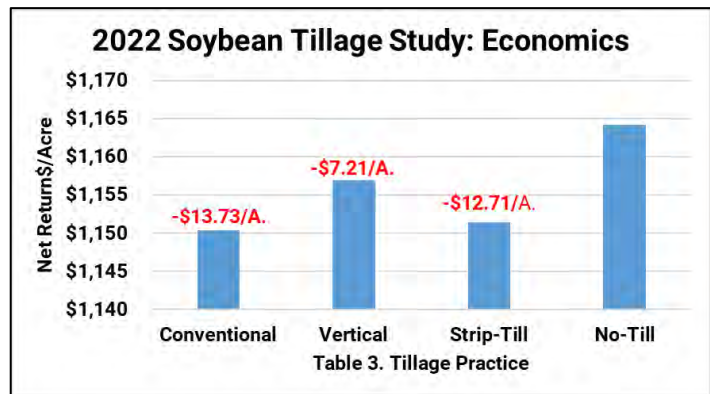
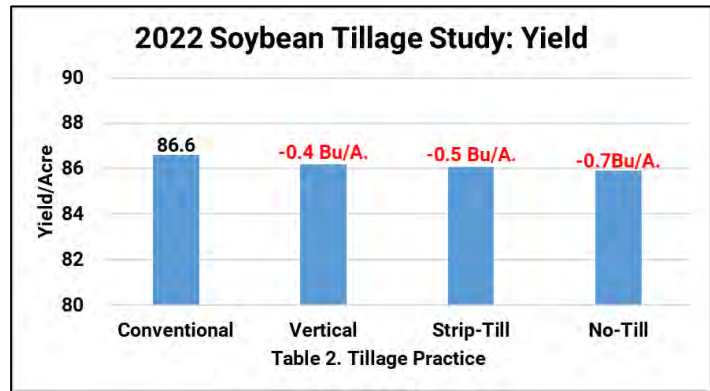

Soybean Pre-Strip Vertical Tillage Study

Objective: To evaluate the yield and economic benefit of implementing a vertical tillage (Figure 1.) in corn stalks before a fall strip-till application (Figure 2.) to aid stalk decomposition.

Results: Vertical tillage made pre-strip-till proved to be recreational tillage with a +0 Bu/A. yield contribution. As a result, net economic losses occurred of **-\$13.20/A.**

Tillage Practice	Category	Cost
Conventional Till	Ripper	\$ 27.70
	Soil Finisher	\$ 13.60
	Plant	\$ 17.20
	Total:	\$ 58.50
Strip Till	Strip	\$ 17.30
	Burndown	\$ 8.00
	Plant	\$ 17.20
	Total:	\$ 42.50
Vertical Till	Vertical	\$ 13.20
	Burndown	\$ 8.00
	Plant	\$ 17.20
	Total:	\$ 38.40
No Till	Burndown	\$ 8.00
	Plant	\$ 19.00
	Total:	\$ 27.00



Figure 2. Kuhn® Krause Gladiator



Figure 1. Sunflower® 6833 Vertical Tillage Before Strip-Till

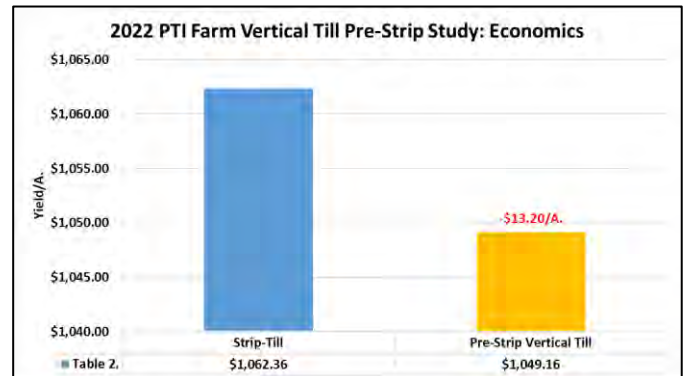
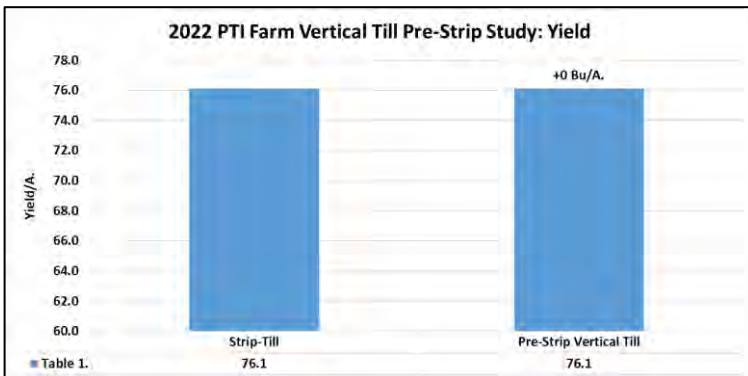

Chopping Corn Head Study

Objective: To study the yield impact of utilizing a chopping corn head in a corn/soybean conventional tillage rotation. A Capello Quasar™ chopping head is used to create replicated strips of chop and non-chop residue management trials. The goal of this trial is to evaluate sizing of residue, allowing heavy stalks and residue to break down faster to advance the degradation process and in turn, reducing the carbon penalty associated with continuous corn environment.

Results: Table 1. illustrates that chopping corn residue improved soybean yields by +1.1 Bu/A. At a soybean commodity price of \$13.96/Bu, this resulted in additional gross revenue of +\$15.36/A.

Multi-year data from 2017-2022 indicates yield advantages of +1.1 to +3.3 Bu/A.

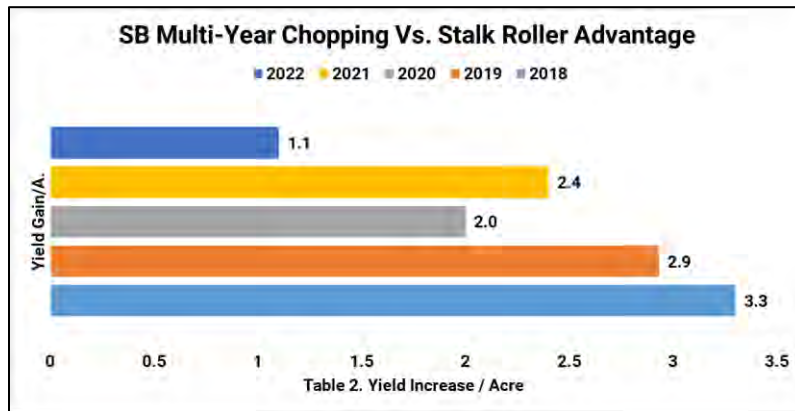

Soybean Row Width & Seeding Rate Study

Objective: This trial evaluates the agronomic and economic impact of planting two soybean varieties (Asgrow® 27XF1 and 35XF1) at seeding rates ranging from 50K to 175K in 15" and 30" row spacing.

30" Wide Row Results:

- ✓ Asgrow® 27XF1 achieved both agronomic and economic optimum seeding rate at 100K/A.
- ✓ High yield was 71.3 Bu/A.
- ✓ Low seeding rates of 50K/A. resulted in minimal yield losses of **-2.0 Bu/A.**, proving economic losses of **-\$6.49/A.**
- ✓ Over-seeding at 125-175K rates resulted in yield losses of **-0.8 Bu/A** to **-3.5 Bu/A.** with respective economic losses of **-\$21.88** to **-\$81.00/A.**

- ✓ Asgrow® 35XF1 achieved agronomic yield at 100K seeding rates, however economic optimum at only 75K/A.
- ✓ High yield was 75.7 Bu/A.
- ✓ Overseeding at 125K to 175K resulted in huge yield losses of -3.1 to 7.0 Bu/A. with corresponding economic losses of **-\$64.70** to **-\$140.58/A.**

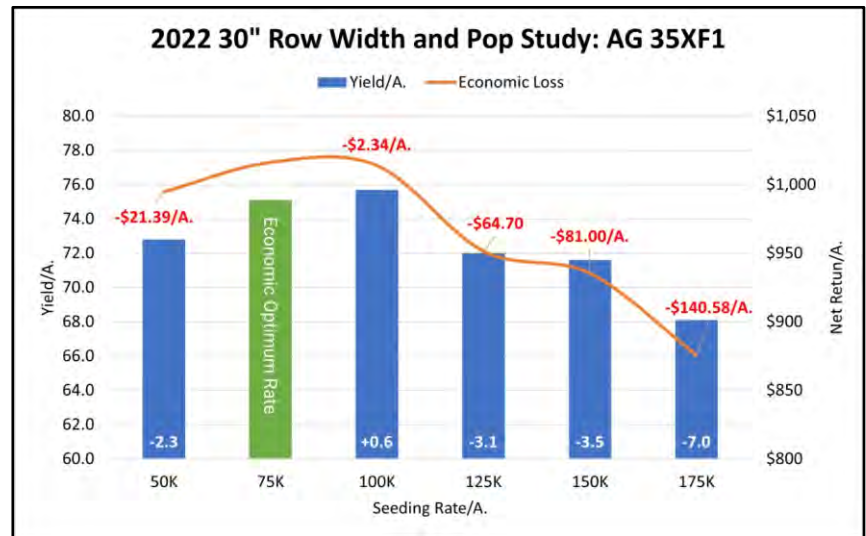
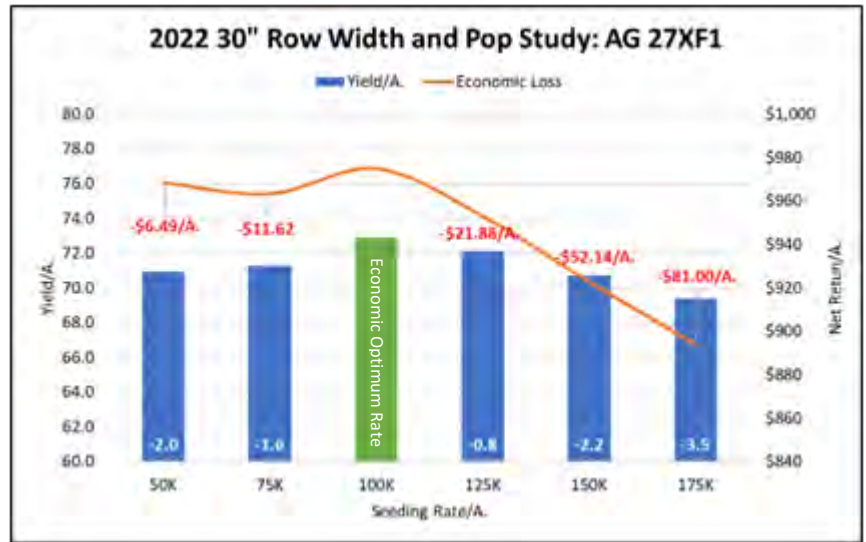

Soybean Row Width & Seeding Rate Study Continued

15" Narrow Row Results:

- ✓ Asgrow® 27XF1 achieved both agronomic yield at 150K, while economic optimum seeding rate at 125K/A.
- ✓ High yield was 77.1 Bu/A.
- ✓ Lower seeding rates of 75K/A. resulted in highest yield losses of **-5.7 Bu/A.**, proving economic losses of **-\$58.15/A.**
- ✓ Over-seeding at 150-200K rates resulted in economic losses of **-\$9.32/A.** and **-\$27.01/A.**

- ✓ Asgrow® 35XF1 achieved both agronomic and economic seeding rate at 100K/A.
- ✓ High yield was 70.3 Bu/A.
- ✓ Low seeding rates of 75K/A. resulted in yield losses of **-2.2 Bu/A.**, proving economic losses of **-\$20/A.**
- ✓ Over-seeding at 150-175K resulted in yield losses of **-1.2 Bu/A** to **-2.3 Bu/A.** with respective economic losses of **-\$38.18** and **-\$64.25/A.**

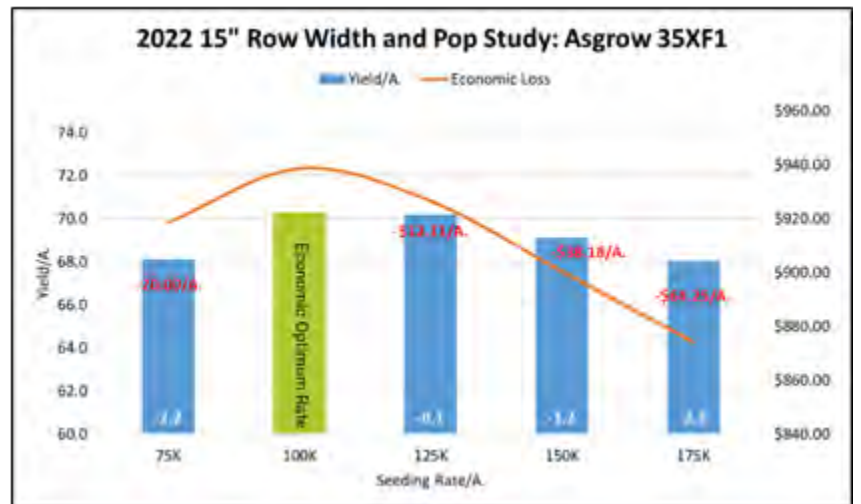
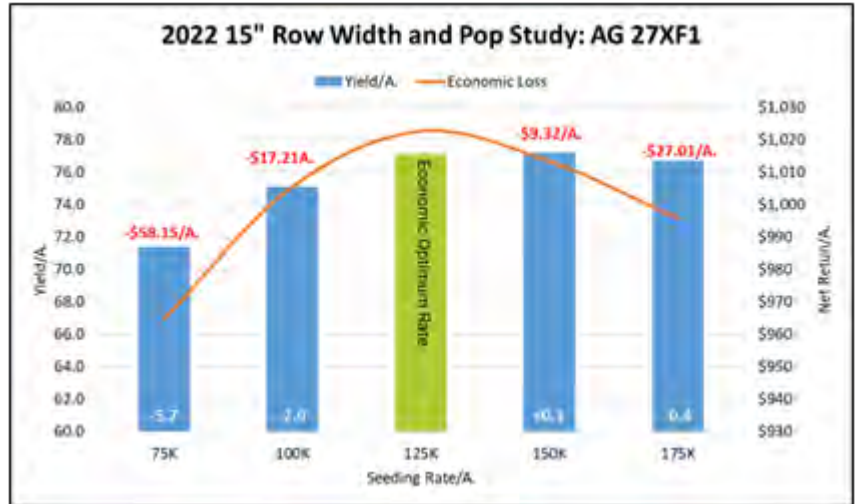

Soybean Row Width & Seeding Rate Study Continued

15" vs 30" Row Width Summary:

- ✓ In popular or common seeding rates today of 100K to 150K, 15" rows out-performed wide 30" rows by only +0.7 Bu/A.
- ✓ +0.7 Bu/A. yield gains at \$13.96/Bu. soybeans proves additional revenue of +\$9.77/A.
- ✓ Multi-Year data at the PTI Farm has resulted in narrow row advantages of +3.36 Bu/A. with additional net revenue of +\$36.14/A.

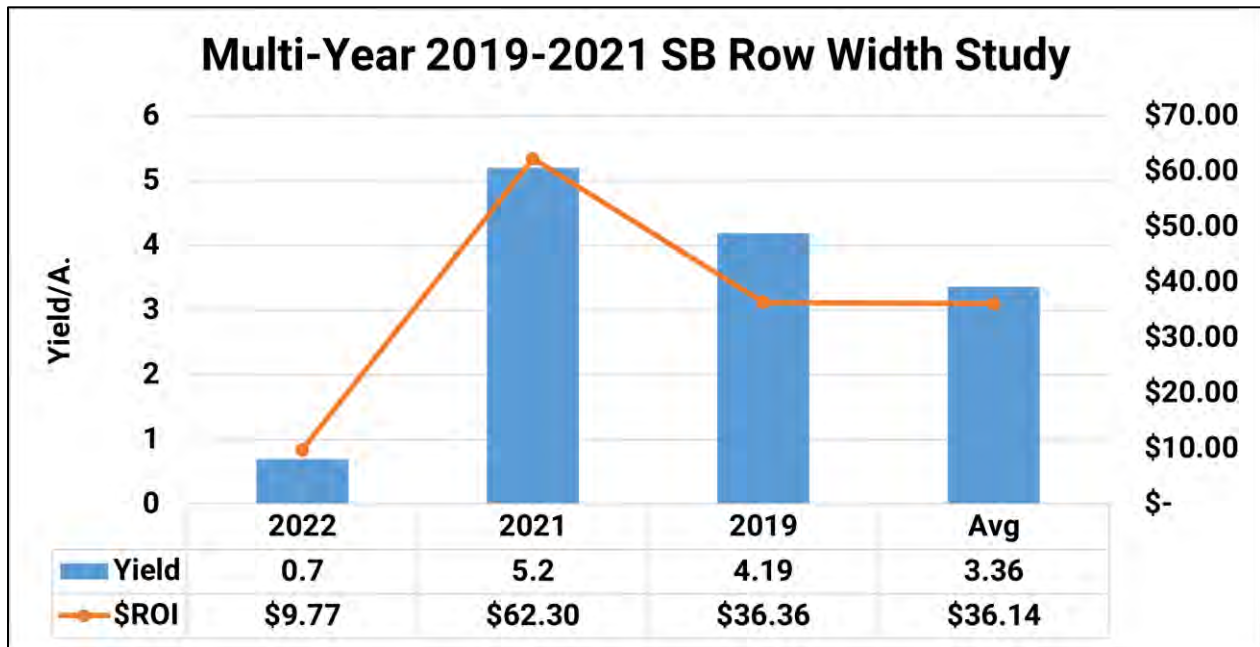

Planting Date: May 19th Variety: AG 35XF1, 27XF1 Population: Varied Row Width: 20/30" Rotation: BAC SB Price: \$13.96 Seed: \$60/Bag

Wrap Up

Precision Planting is excited to share our 2022 PTI research farm results and findings. We hope they provide useful insights that help drive thoughtful consideration around future crop management. The PTI Farm is working diligently to continue with long-term studies that provide multi-year data analysis for decision-making purposes. We will continue to work with our Precision Planting Premier Dealers to identify opportunities to find new research objectives, driving innovation and development of new solutions in the field. Precision Planting continues to find new ways to provide commitment to the development of innovations and insights that allow for the highest yield and ROI opportunities for your farm and family.

One of our goals at the PTI Farm is to continue to bring new, fresh, and unique ideas, so that when growers visit the farm they see and experience new technology. “Challenging the Status Quo” is an important concept to us and we always want to offer the opportunity for growers to experience, compare, and challenge their traditional ways of farming to other means. We all know that change is inevitable, but knowing what and when to change is critical to a business. At the PTI farm, we are excited about all of the agronomic trials slated for 2023 and you will not want to miss our upcoming field days. We look forward to seeing you throughout July-September at the Precision Planting Precision Technology Institute at Pontiac, IL.

Precision Planting would like to extend our sincere gratitude to the support and dedication of our Precision Planting Premier Dealers. Precision Planting Premier Dealers are world-class certified precision agriculture experts, with rigorous training and knowledge of the industry and issues facing farmers today. Our Premier Dealers are experienced professionals helping you know more, and ultimately creating more yield and profitability.

The ability to provide unbiased and objective insights into the agronomic research is important to us and we appreciate all Premier Dealers who scheduled and invited growers to the farm in 2022. If you are interested in visiting the PTI Farm in 2023, please contact a Precision Planting Premier Dealer to schedule your visit to the PTI Farm. For your convenience, click here to use our Dealer Locator to find the Precision Planting Premier Dealer nearest you.

http://www.precisionplanting.com/#dealer_locator/



PRECISION TECHNOLOGY INSTITUTE

All the research summarized here, was conducted as part of multiple research plots, by a team of experienced staff at the Precision Technology Institute research farm in Pontiac, Illinois. PTI is committed to challenging the status quo, to give growers agronomic insights and the tools that can help provide improved yield and economic bottom line on your own farm.

One of the questions that you may be asking after reviewing the extensive data and results from our 2022 research plots, is why? Why implement over 100 research plots, over 400 acres, with daily on-farm visits and agronomic discussions, through this time of uncertainty and so many new unknowns. The answer is what it has always been; we must continue to challenge the status quo. We must find better, smarter, and higher return on investment solutions for the growers and their farms. Precision Planting created the Precision Technology Institute in Pontiac, Illinois to provide a place for growers to meet and learn, while providing results of research plots that illustrate the practical value of their products in real world situations. The research we are sharing is designed by Precision Planting to better understand what solutions, in combination with real-world scenarios can actually provide, both a yield and economic benefit. These are learnings that we will continue to develop, implement, study and share, to provide our growers with the tools to help improve their bottom line.

Precision Technology Institute feels the best way to serve this goal to growers is as simple as having conversations. As part of this vision of having an on-going dialogue with growers, there are many ways to become part of the learnings and findings throughout the year, including an exciting new opportunity to visit PTI's new state of the art facility.



Become an Insider

A simple way to stay informed, as well as up to date on the research we are collecting here at the PTI Farm is to become an Insider. Subscribe to the InsidePTI weekly videos at insidepti.com for all your agronomic needs.



Come Visit us at the New Home of PTI

While a lot of research was happening over the year, PTI also has been breaking ground and completing the vision of a showplace for Precision Planting and growers to meet to continue conversations. In the late fall of 2020, we built a new home and enjoyed showing it to thousands of visitors as they came to our field days during the summer. We look forward to sharing this beautiful complex with more growers in the future and are excited to use it as an avenue to have more amazing conversations and learning opportunities with growers through-out the years to come.



More New Construction

The Precision Technology Institute is proud to announce our joint venture with GSI Grain Systems on a brand new state of the art grain drying and storage system. This project will be complete by summer 2023 and we invite you to come see and understand how the PTI Farm Team will use this technology in relation to agronomy testing at the PTI Farm.



Come Experience Field Days at PTI

So what can you expect when attending summer field days at PTI? Whether you are a frequent visitor or looking forward to your first visit, PTI field days are a high energy, information packed, learning experience. Here are some of the one of a kind experiences you can choose to take advantage of all provided by Precision Planting at the Precision Technology Institute.

- **The Driver's Seat**

In our 27-acre sandbox, you take the wheel. Here, we hand YOU the keys to different tractor/planter combinations and allow you to run the equipment in real time, learning more in depth about how each piece works and the technology behind it. Precision Planting Support Technicians will be co-piloting in the buddy seat at this time, to answer any questions that may come about throughout your experience.

- **Core Principles and Planting Fundamentals**

This hands-on demo is led by the Precision Planting Regional Managers walking the growers through the importance of planter maintenance and furrow creation. Growers can see in person correct and incorrect furrow creation from two different planter row units. During this time, growers can interactively measure and correct the furrow created throughout the different planting conditions.

- **Agronomy Tour**

Lead Agronomist and PTI Farm Director, Jason Webster, takes you out into the field to dive deeper into the innovative agronomy and technology that we use each season throughout the different plots. You will learn about our new water recycling and tile drainage system, research tools, and technology/products available to implement on your farm.

- **Industry Days**

Each year, we invite industry partners to use PTI as an avenue to showcase their products and technology during the year. These customer focused field days are led by the industry partner's employees. If you are interested in hosting an industry day or becoming an industry partner of Precision Planting, contact the PTI Team at ptipontiac@precisionplanting.com.

For more information regarding attendance of a PTI Field Day or Industry Day, reach out to your Precision Planting Premier Dealer or visit our website at precisionplanting.com/events to schedule a visit.

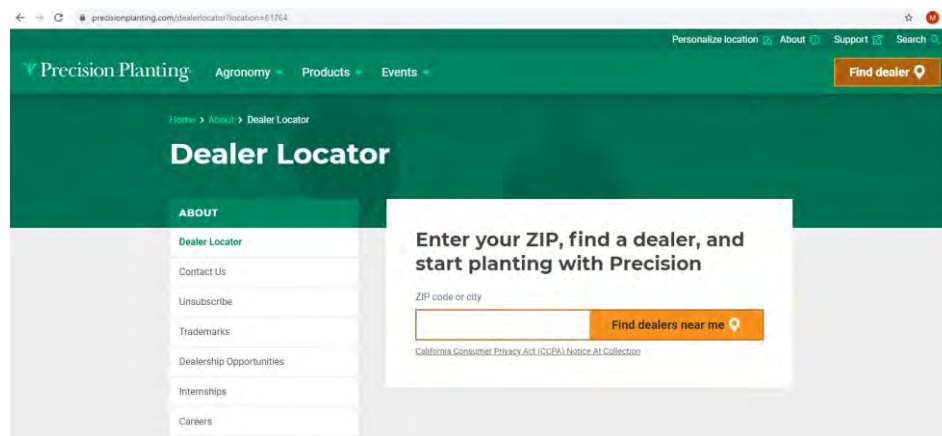

E

Acknowledgements and Legal Statement

vSet®, SmartFirmer®, Keeton®, CleanSweep®, SpeedTube®, DeltaForce®, vDrive®, FurrowJet®, Conceal®, mSet®, 20|20®, SmartDepth®, FurrowForce®, Reveal®, and WaveVision® are all Trademarks of Precision Planting, LLC. imPulse®, Triple Option®, K-Fuse®, Nachurs Finish line®, Start2Finish®, bio-K®, Nachurs Throwback®, Nachurs First Down®, Rhyzo-Link®, Nachurs Humi-Flex®, Nachurs SideSwipe®, Nachurs K-Flex® Max, Nachurs Humi-Flex® FA, Nachurs K-Fuel®, Balance®, Aqua Tech®, Nachurs® 10% Boron and Nachurs® 10% Molybdenum are trademarks of Nachurs Alpine Solutions. Wholeshot, Compost Tea, Macrosorb RZT, Pacific Gro, Yucca, Sea Crop, High Energy Fish, Big Shot are products of Nutrient Management Specialists LLC. Charge12%™, Harvest Plus™, Stimulant Yield Enhancer®, Sugar Mover®, Harvest More®, Bio-Forge®, and X-Cyte™ are trademarks of Stoller@USA. Kelpak® trademark of Kelp Products International (Pty) Ltd. Pro-Germinator®, AccesS™, FertiRain®, Sure-K®, Springup®, Micro 500®, Kapitalize®, eNhance™, Kalibrate® are trademarks of AgroLiquid LLC. Uptake® Starter, EnzUp®, Sulfer Plus™, Brandt Smart Trio®, Brandt SmartKB™ are trademarks of BRANDT®. MicroAZ-IF Liquid™ and MicroAZ-ST Dry™ are trademarks of TerraMax LLC. BioMarc, Nitro “K”, NutriStart™, NutriComplete, Boost and QuickGrow LTE are all products of Marco N.P.K. Inc. QLF™ 7-21-3 MKP, Boost and Amino-15™ are trademarks of QLF™. The Andersons®, Season Pass®, Over Pass®, Korrekt® Plus, UltraMate™, SweetNEezy™, PhosFix®, FirstPass®, MicroBlitz®, Eezy® K, Eezy® MolyB, MicroMark® DG, Bio Pass™ and Microcarb®, are trademarks The Andersons, Inc. Nano-CS®, NanoN+®, NanoN™, CXPro, Nano-K®, Nano Pro® are trademarks of Aqua Yield operations. NutriCharge® is a trademark of AGROTECH. Corn Mix LS, and Zinc 10% LS is a trademark of Winfield United. MicroPack 5-5-5™ a product of Midwestern NioAg. MicroSync™ Complete® a trademark of Verdesian. TerraMax Liquid-IF™ is a product of TerraMax Ag inc. STRIDEBIO® is a trademark of Rosens. Rootella® is a trademark of Groundwork BioAg. Soileos® a trademark of Lucent Biosciences, inc. Envita® is a trademark of Engage Agro Corporation. Sandy-Cal, Grain Gain, Nutri-Shield, Power Pro II, Calcean, Sea-90™, Elevation and Aragonite are products of Ocean Blue Ag. ProveN®40 is a trademark of Pivot Bio. NETAFIM® is a Trademark of Netafim LLC. NutriDrip System is a product from Kurt Grimm. Dimple closing wheels are a product from Martin-till. 360 Wave™ is a trademark of 360 Yield Center™. Sunflower®, Fendt®, and Momentum® are trademarks of AGCO. Quasar™ is a trademark of Capello Inc. KUHN®, Krause®, and Gladiator® are trademarks of KUHN North America Inc. Montag® is a trademark of Montag Mfg. ADI™ is a trademark of Ag Drainage Inc. Twister® a trademark of YETTER Manufacturing CO., INC. John Deere® and John Deere 1770 Planter are trademarks of Deere & Company. Rantizo® is a trademark of Rantizo Inc. Hagie® is a trademark of Hagie Manufacturing Company LLC. NutriMax® Single Coulter, NutriMax® Double Coulter, NutriMax® Dual Delivery System, Brent® V1000 Auger Cart, NutriMax® 1400 Side-Dress Applicator are trademarks of Unverferth Manufacturing. Nitrogen Sealing Systems and N-Place™ are products of Nitrogen Sealing Systems. Veltyma® and Revytek® are trademarks of BASF. Source™ is a trademark of Sound Agriculture. Miravis® Neo and Triva Pro® are all trademarks of Syngenta Corp. S04® and 98G® are trademarks of Calcium Products. Capture®, LFR®, Ethos® XB, Xyway® and Top Guard® are trademarks of FMC Agricultural Solutions. Brandt® Auger Cart 820XT and Brandt 51' Land Roller are trademarks of Brandt®. Case IH® and Early Riser® 2150 are trademarks of CNH Industrial America LLC. Harvest International® Ultra™ Series 40 20" planter is a trademark of Harvest International. STP, STV, and STPS are products from Prescription Tillage Technology L.L.C., Pioneer® is a Trademark of Pioneer Hi-Bred International Inc. AgriGold® is a trademark of AgReliant Genetics, LLC. Dekalb® and Asgrow®, are trademarks of Monsanto Technology, LLC. Golden Harvest® is a trademark of Syngenta Corp.

The University of Illinois Machinery Cost Estimates provided by The University of Illinois Farm Business
The Iowa State University Tillage Rate provided by the Iowa State University Extension and Outreach.